

718e

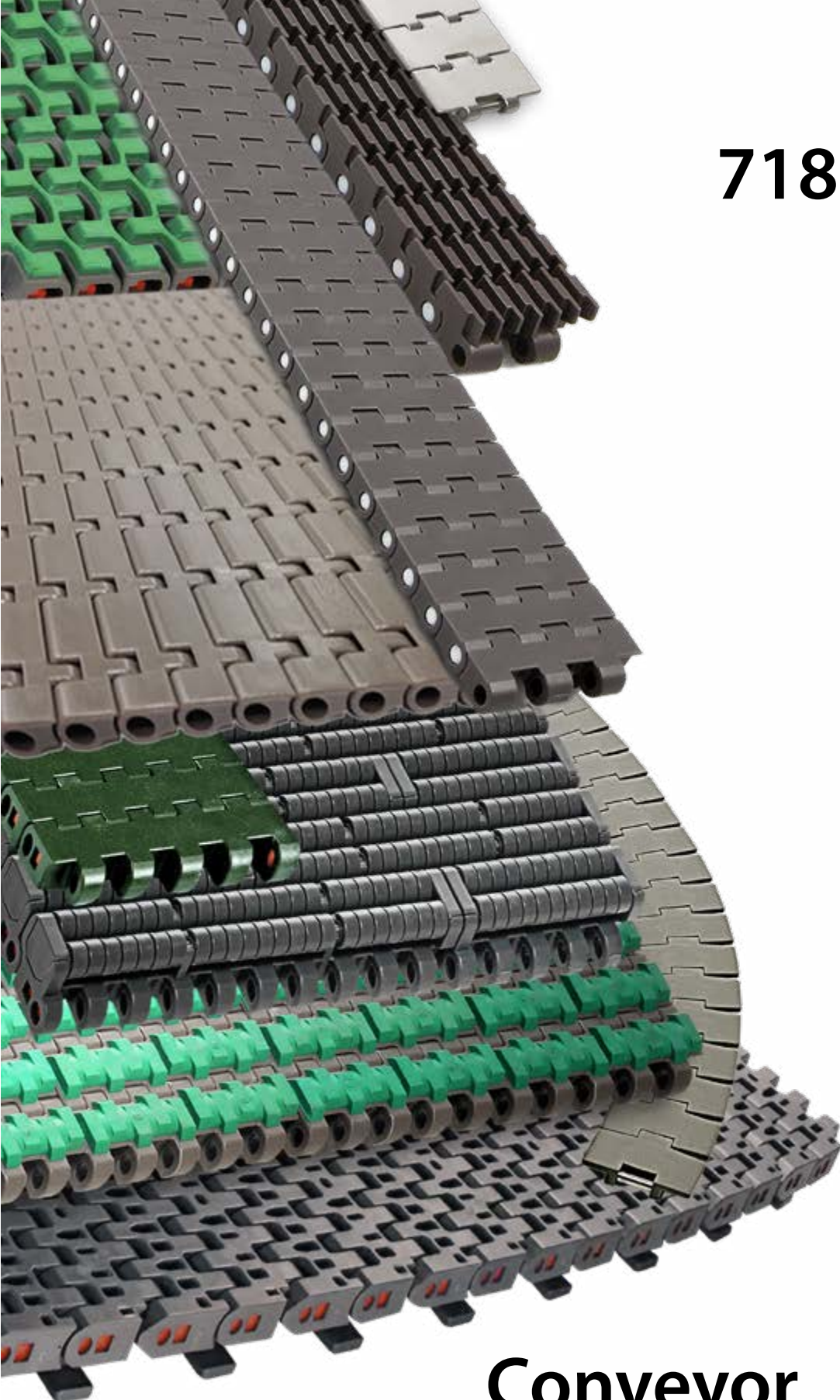

# Conveyor General Catalogue



PERFORMANCE IN MOTION



Copyright Regina Catene Calibrate S.p.A. - 2018

All images, products, decorations, texts, signs of this catalog and their graphic layout are exclusive industrial and intellectual property of Regina Catene Calibrate S.p.A.; it is therefore forbidden the reproduction and / or unauthorized use at any title or reason and in any form.

The content of this brochure is only intended to provide general information and of commercial nature, and it may, at any time, be subject to change at the discretion of Regina Catene Calibrate Spa. Despite all the information has been checked for accuracy and completeness, they may contain errors or inaccuracies in some cases, also due to the continuous updating of production. Therefore, Regina Catene Calibrate S.p.A. cannot be held liable for material or immaterial damages in any way arising from inaccurate or incorrect information contained in this catalog.



# MANAGEMENT SYSTEM CERTIFICATE

Certificato No./Certificate No.:  
CERT-00105-96-AQ-MIL-SINCERT

Data prima emissione/Initial date:  
14 settembre 1993

Validità/Valid:  
05 dicembre 2015 - 15 settembre 2018

Si certifica che il sistema di gestione di/This is to certify that the management system of

## REGINA CATENE CALIBRATE S.p.A.

Sede: Via Monza, 90 - 23870 Cernusco Lombardone (LC) - Italy

È conforme ai requisiti della norma per il Sistema di Gestione Qualità/  
has been found to conform to the Quality Management System standard:

### UNI EN ISO 9001:2008 (ISO 9001:2008)

Questa certificazione è valida per  
il seguente campo applicativo:

**Progettazione, produzione, assistenza pre  
e post vendita di catene industriali  
normalizzate e speciali, di catene per  
applicazioni motociclistiche e motoristiche.  
Produzione di trafilati e laminati in acciaio**

**(Settore EA: 17 - 14)**

This certificate is valid  
for the following scope:

**Design, manufacture, pre and after-sale  
servicing of standardized and special  
industrial chains, chains for motorcycle  
and engine applications. Manufacture of  
drawn steel wire and flattened wire strips**

**(EA Sector: 17 - 14)**

Luogo e Data/Place and date:  
Vimercate, 28 dicembre 2015



SGQ N° 883 A EMAG N° 009 F  
SGA N° 003 D PRO N° 003 B  
SGE N° 003 H PSC N° 004 C  
SCB N° 004 F SSI N° 002 G

Membro di IMA SA per gli schemi di accreditamento  
SGQ, SGA, PRO, PSC, SSI, SPM, SPO, LAB e LAT, di IMA UNI  
per gli schemi di accreditamento SGQ, SGA, SSI, FSM  
e IMA e di IMA ILAC per gli schemi di accreditamento  
LAB, MRO, LAT e ICP

Per l'Organismo di Certificazione/  
For the Certification Body

**Vittore Marangon**  
Management Representative

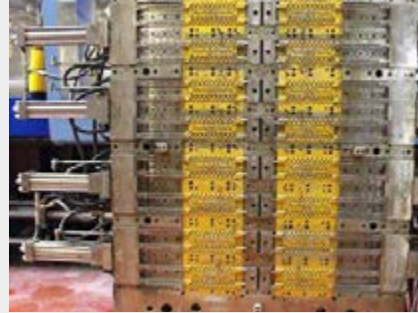

# Since 1919

REGINA offers a vanguard and complete product portfolio of conveyor chains, belts and components, made of a wide range of top tier engineered plastics and steel grades, and available in metric and imperial standards. Our products are a top quality solution for the beverage, packaging and glass industries and for many more applications.

We strongly believe in R&D and heavily invest in our factories, where we manufacture all the products we sell. We operate worldwide through a fully owned subsidiaries network with strong local technical knowledge and a large stock.

Established in 1919, REGINA is now owned by the same family since 4 generations.







**PERFORMANCE IN MOTION**

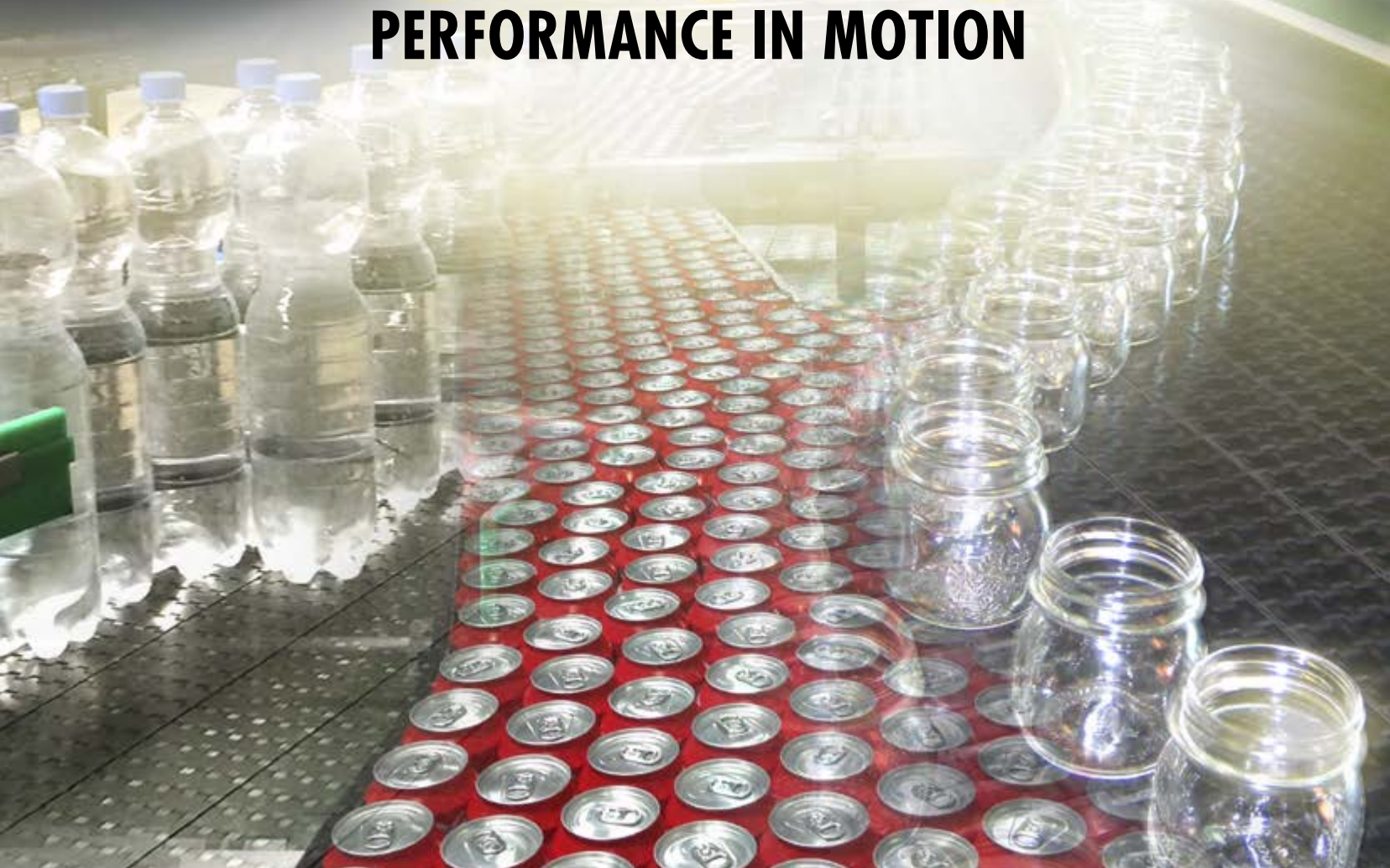



## STRAIGHT RUNNING STEEL CHAINS

**FliteTop**

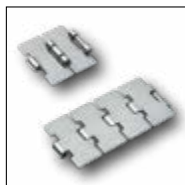

**915**  
Single hinge  
Reduced plate gap (1,6 mm)  
Pitch 1 1/2" (38,1 mm)  
Thickness 3 mm (0.118")  
Hinge 42 mm (1.654")

Page 28



**PHD 915**  
Single hinge  
Reduced plate gap (1,6 mm)  
Increased pin hardness  
Pitch 1 1/2" (38,1 mm)  
Thickness 3 mm (0.118")  
Hinge 42 mm (1.654")

Page 29

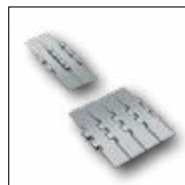

**2815**  
Double hinge  
Pitch 1 1/2" (38,1 mm)  
Thickness 3 mm (0.118")  
Hinge 80 mm (3.150")

Page 29

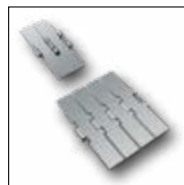

**PHD 9157**  
Heavy duty single hinge  
Increased pin hardness  
Pitch 1 1/2" (38,1 mm)  
Thickness 3 mm (0.118")  
Hinge 57 mm (2.244")

Page 31



**803**  
Mini hinge  
Pitch 1 1/2" (38,1 mm)  
Thickness 3 mm (0.118")  
Hinge 22 mm (0.866")

Page 32

## SIDEFLEXING STEEL CHAINS

**FliteTop**

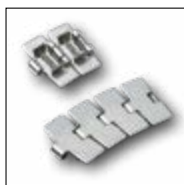

**881**  
Bevel  
Pitch 1 1/2" (38,1 mm)  
Thickness 3 mm (0.118")  
Hinge 43 mm (1.693")

Page 33



**981**  
Bevel  
Reduced plate gap  
Pitch 1 1/2" (38,1 mm)  
Thickness 3 mm (0.118")  
Hinge 43 mm (1.693")

Page 34

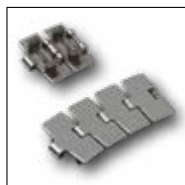

**881T**  
TAB  
Pitch 1 1/2" (38,1 mm)  
Thickness 3 mm (0.118")  
Hinge 43 mm (1.693")

Page 35



**981T**  
TAB  
Reduced plate gap  
Pitch 1 1/2" (38,1 mm)  
Thickness 3 mm (0.118")  
Hinge 43 mm (1.693")

Page 36

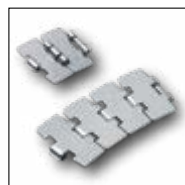

**981M**  
Magnetic  
Reduced plate gap  
Pitch 1 1/2" (38,1 mm)  
Thickness 3 mm (0.118")  
Hinge 42 mm (1.654")

Page 37



**PHD 981M**  
Magnetic  
Reduced plate gap  
Increased pin hardness  
Pitch 1 1/2" (38,1 mm)  
Thickness 3 mm (0.118")  
Hinge 42 mm (1.654")

Page 38

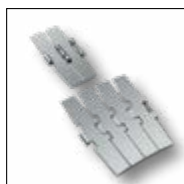

**PHD 9857M**  
Magnetic  
Heavy duty single hinge  
Increased pin hardness  
Pitch 1 1/2" (38,1 mm)  
Thickness 3 mm (0.118")  
Hinge 57 mm (2.244")

Page 39



**982T**  
TAB  
Reduced sideflexing  
radius (200 mm)  
Pitch 1 1/2" (38,1 mm)  
Thickness 3 mm (0.118")  
Hinge 43 mm (1.693")

Page 40

## RUBBERIZED SURFACE STEEL CHAINS

**FliteTop**



**PHD 915**  
Straight running  
Single hinge  
Increased pin hardness  
Pitch 1 1/2" (38,1 mm)  
Thickness 3 mm (0.118")  
Hinge 42 mm (1.654")

Page 41

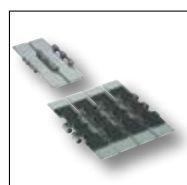

**PHD 2815**  
Straight running  
Double hinge  
Increased pin hardness  
Pitch 1 1/2" (38,1 mm)  
Thickness 3 mm (0.118")  
Hinge 80 mm (3.150")

Page 42

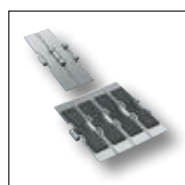

**PHD 9157**  
Straight running  
Heavy duty single hinge  
Increased pin hardness  
Pitch 1 1/2" (38,1 mm)  
Thickness 3 mm (0.118")  
Hinge 57 mm (2.244")

Page 43

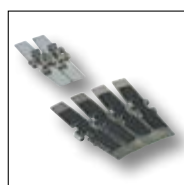

**PHD 981T**  
Sideflexing TAB  
Reduced plate gap  
Increased pin hardness  
Pitch 1 1/2" (38,1 mm)  
Thickness 3 mm (0.118")  
Hinge 43 mm (1.693")

Page 44

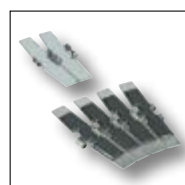

**PHD 981M**  
Sideflexing magnetic  
Reduced plate gap  
Increased pin hardness  
Pitch 1 1/2" (38,1 mm)  
Thickness 3 mm (0.118")  
Hinge 42 mm (1.654")

Page 45



**PHD 9857M**  
Sideflexing magnetic  
Heavy duty single hinge  
Increased pin hardness  
Pitch 1 1/2" (38,1 mm)  
Thickness 3 mm (0.118")  
Hinge 57 mm (2.244")

Page 46

## STRAIGHT RUNNING PLASTIC CHAINS

**FliteTop®**

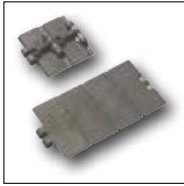

**820**  
Single hinge  
Pitch 1 1/2" (38,1 mm)  
Thickness 4 mm (0.157")  
Hinge 41,6 mm (1.638")

Page 49

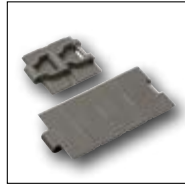

**828**  
Reinforced single hinge  
Reduced plate gap  
Pitch 1 1/2" (38,1 mm)  
Thickness 4 mm (0.157")  
Hinge 42 mm (1.654")

Page 50

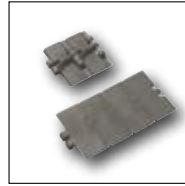

**831**  
Single hinge  
Reinforced top plate  
Pitch 1 1/2" (38,1 mm)  
Thickness 4,8 mm (0.189")  
Hinge 41,6 mm (1.638")

Page 51

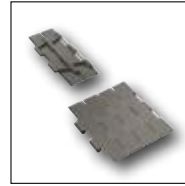

**821**  
Double hinge  
Reinforced top plate  
Pitch 1 1/2" (38,1 mm)  
Thickness 4,8 mm (0.189")  
Hinge 136,5 mm (5.374")

Page 52

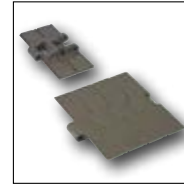

**8257**  
Heavy duty single hinge  
Reinforced top plate  
Pitch 1 1/2" (38,1 mm)  
Thickness 4,8 mm (0.189")  
Hinge 57 mm (2.244")

Page 53

## SIDEFLEXING PLASTIC CHAINS

**FliteTop®**

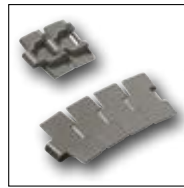

**880**  
Bevel  
Pitch 1 1/2" (38,1 mm)  
Thickness 4 mm (0.157")  
Hinge 43 mm (1.693")

Page 54

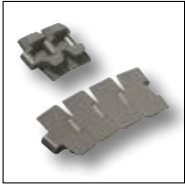

**880T**  
TAB  
Pitch 1 1/2" (38,1 mm)  
Thickness 4 mm (0.157")  
Hinge 42,9 mm (1.689")

Page 55

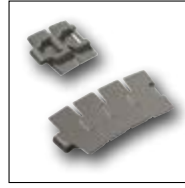

**880M RG**  
Magnetic  
Reduced plate gap  
Pitch 1 1/2" (38,1 mm)  
Thickness 4 mm (0.157")  
Hinge 42 mm (1.654")

Page 56

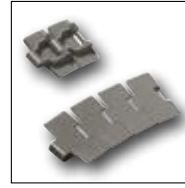

**879**  
Bevel  
Reinforced top plate  
Pitch 1 1/2" (38,1 mm)  
Thickness 4,8 mm (0.189")  
Hinge 43 mm (1.693")

Page 57

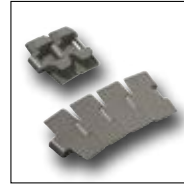

**879T**  
TAB  
Reinforced top plate  
Pitch 1 1/2" (38,1 mm)  
Thickness 4,8 mm (0.189")  
Hinge 42,9 mm (1.689")

Page 58

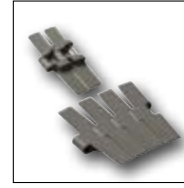

**882**  
Bevel  
Heavy duty single hinge  
Reinforced top Plate  
Pitch 1 1/2" (38,1 mm)  
Thickness 4,8 mm (0.189")  
Hinge 61 mm (2.402")

Page 59



**882T**  
TAB  
Heavy duty single hinge  
Reinforced top Plate  
Pitch 1 1/2" (38,1 mm)  
Thickness 4,8 mm (0.189")  
Hinge 57 mm (2.244")

Page 60

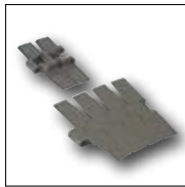

**882M**  
Magnetic  
Heavy duty single hinge  
Reinforced top Plate  
Pitch 1 1/2" (38,1 mm)  
Thickness 4,8 mm (0.189")  
Hinge 57 mm (2.244")

Page 61



**878T**  
TAB  
Reinforced top Plate  
Reduced sideflexing  
radius (200 mm)  
Pitch 1 1/2" (38,1 mm)  
Thickness 4,8 mm (0.189")  
Hinge 42,9 mm (1.689")

Page 62

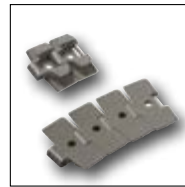

**880TA**  
TAB  
Vacuum series  
Pitch 1 1/2" (38,1 mm)  
Thickness 4 mm (0.157")  
Hinge 42,9 mm (1.689")

Page 63

## RUBBERIZED SURFACE PLASTIC CHAINS

**FliteTop®**

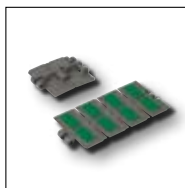

**HFX 820**  
Straight running  
Single hinge  
Pitch 1 1/2" (38,1 mm)  
Thickness 4 mm (0.157")  
Hinge 41,6 mm (1.638")

Page 65

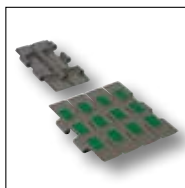

**HFX 821**  
Straight running  
Double hinge  
Pitch 1 1/2" (38,1 mm)  
Thickness 4,8 mm (0.189")  
Hinge 136,5 mm (5.374")

Page 66

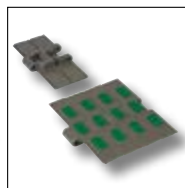

**HFX 8257**  
Straight running  
Heavy duty single hinge  
Reinforced Top Plate  
Pitch 1 1/2" (38,1 mm)  
Thickness 4,8 mm (0.189")  
Hinge 57 mm (2.244")

Page 67

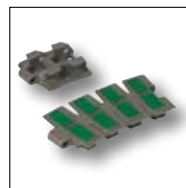

**HFX 880T**  
Sideflexing TAB  
Pitch 1 1/2" (38,1 mm)  
Thickness 4 mm (0.157")  
Hinge 42,9 mm (1.689")

Page 68

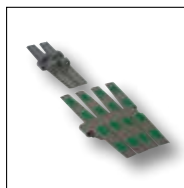

**HFX 882T**  
Sideflexing TAB  
Heavy duty single hinge  
Reinforced Top Plate  
Pitch 1 1/2" (38,1 mm)  
Thickness 4,8 mm (0.189")  
Hinge 57 mm (2.244")

Page 69

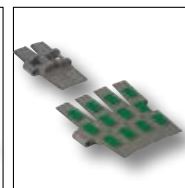

**HFX 882M**  
Sideflexing Magnetic  
Heavy duty single hinge  
Reinforced Top Plate  
Pitch 1 1/2" (38,1 mm)  
Thickness 4,8 mm (0.189")  
Hinge 57 mm (2.244")

Page 70



**HFX 1873T**  
Two Piece  
Sideflexing TAB  
Pitch 3/4" (19,05 mm)  
Thickness 4 mm (0.157")  
Hinge 32,1 mm (1.264")

Page 71

## TWO-PIECE CHAINS

**FliteTop**

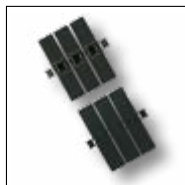

### 1864

Straight running  
Steel flights  
Pitch 3/4" (19,05 mm)  
Thickness 3 mm (0.118")  
Hinge 27 mm (1.063")

Page 74

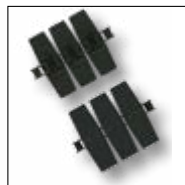

### 1874T/1874TM

Sidexflexing TAB  
Steel flights  
Flight gap 8,2 mm  
Reduced flight gap 5,7 mm (1874TM)  
Pitch 3/4" (19,05 mm)  
Thickness 3 mm (0.118")  
Hinge 31,8 mm (1.252")

Page 75

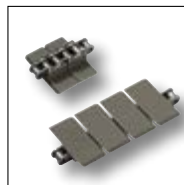

### 843

Straight running  
Plastic flights  
Pitch 1/2" (12,7 mm)  
Thickness 3.2 mm (0.126")  
Hinge 20,6 mm (0.811")

Page 76



### 845

Straight running  
Plastic flights  
Bidirectional  
Pitch 1/2" (12,7 mm)  
Thickness 3.2 mm (0.126")  
Hinge 20,6 mm (0.811")

Page 77



### RR 845

Straight running  
Plastic flights  
Bidirectional  
Raised rib  
Pitch 1/2" (12,7 mm)  
Thickness 12,2 mm (0.480")  
Hinge 20,6 mm (0.811")

Page 78

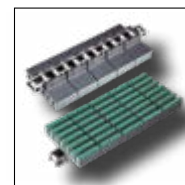

### HF RR 845

Straight running  
Plastic flights  
Bidirectional  
Rubberized raised rib  
Pitch 1/2" (12,7 mm)  
Thickness 12,2 mm (0.480")  
Hinge 20,6 mm (0.811")

Page 7

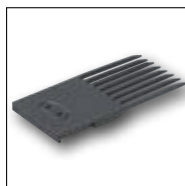

### Transfer combs

For HF RR 845 belts

Page 80



### 863

Straight running  
Plastic flights  
Pitch 3/4" (19,05 mm)  
Thickness 4 mm (0.157")  
Hinge 34,1 mm (1.343")

Page 81



### 1843T

Sidexflexing TAB  
Plastic flights  
Pitch 1/2" (12,7 mm)  
Thickness 3.2 mm (0.126")  
Hinge 20 mm (0.787")

Page 82

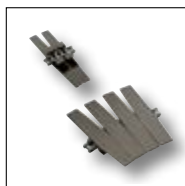

### 1873T

Sidexflexing TAB  
Plastic flights  
Pitch 3/4" (19,05 mm)  
Thickness 4 mm (0.157")  
Hinge 32,1 mm (1.264")

Page 83

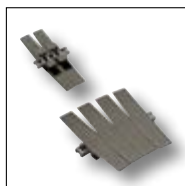

### 1863T

Sidexflexing TAB  
Plastic flights  
Reduced flight gap  
Pitch 3/4" (19,05 mm)  
Thickness 4 mm (0.157")  
Hinge 32,1 mm (1.264")

Page 84



### 1883

Spiral chain  
Plastic flights  
Integrated bearings  
Pitch 1" (25,4 mm)  
Thickness 4,8 mm (0.189")  
Hinge 42,9 mm (1.689")

Page 85



### HFX 1883

Spiral chain  
Rubberized plastic flights  
Integrated bearings  
Pitch 1" (25,4 mm)  
Thickness 4,8 mm (0.189")  
Hinge 42,9 mm (1.689")

Page 86

PRODUCTION RANGE



## GRIPPER CHAINS

**FliteTop**



### GV 1874T

Two - piece  
Steel flights  
Short fingers  
Pitch 3/4" (19,05 mm)  
Thickness 3 mm (0.118")  
Hinge 31,8 mm (1.252")

Page 90

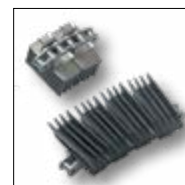

### EV 1874T

Two - piece  
Steel flights  
Long fingers  
Pitch 3/4" (19,05 mm)  
Thickness 3 mm (0.118")  
Hinge 31,8 mm (1.252")

Page 91

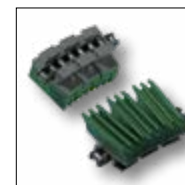

### GW 1873T

Two - piece  
Plastic flights  
Short fingers  
Pitch 3/4" (19,05 mm)  
Thickness 4 mm (0.157")  
Hinge 32,1 mm (1.264")

Page 92

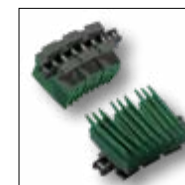

### EW 1873T

Two - piece  
Plastic flights  
Long fingers  
Pitch 3/4" (19,05 mm)  
Thickness 4 mm (0.157")  
Hinge 32,1 mm (1.264")

Page 93

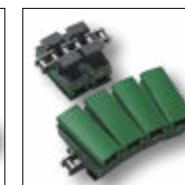

### GD 1873T

Two - piece  
Plastic flights  
D-shape  
Pitch 3/4" (19,05 mm)  
Thickness 4 mm (0.157")  
Hinge 32,1 mm (1.264")

Page 94

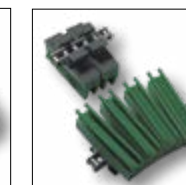

### GU 1873T

Two-piece  
Plastic Flights  
U-shape  
Pitch 3/4" (19,05 mm)  
Thickness 4 mm (0.157")  
Hinge 32,1 mm (1.264")

Page 95



### GD 1873T

Two - piece  
Plastic flights  
D-shape  
Pitch 3/4" (19,05 mm)  
Thickness 4 mm (0.157")  
Hinge 32,1 mm (1.264")

Page 96



### GC 1873T

Two-piece  
Plastic flights  
"House"-shape rubber  
Pitch 3/4" (19,05 mm)  
Thickness 4 mm (0.157")  
Hinge 32,1 mm (1.264")

Page 97



### EW 1843T

Two-piece  
Plastic Flights  
Long Fingers  
Pitch 1/2" (12,7 mm)  
Thickness 3,3 mm (0.130")  
Hinge 19,85 mm (0.781")

Page 98



### GW 878T

One - piece  
Plastic plates  
Short fingers  
Pitch 1 1/2" (38,1 mm)  
Thickness 4,8 mm (0.189")  
Hinge 42,9 mm (1.689")

Page 99

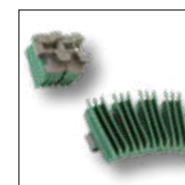

### EW 878T

One - piece  
Plastic plates  
Long fingers  
Pitch 1 1/2" (38,1 mm)  
Thickness 4,8 mm (0.189")  
Hinge 42,9 mm (1.689")

Page 100

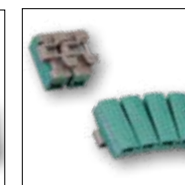

### GD 878T

One - piece  
Plastic plates  
D-shape  
Pitch 1 1/2" (38,1 mm)  
Thickness 4,8 mm (0.189")  
Hinge 42,9 mm (1.689")

Page 101

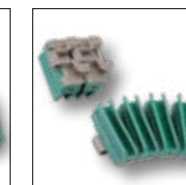

### GU 878T

One - piece  
Plastic plates  
U-shape  
Pitch 1 1/2" (38,1 mm)  
Thickness 4,8 mm (0.189")  
Hinge 42,9 mm (1.689")

Page 102



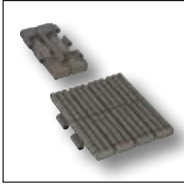

**LBP 821**  
Straight running  
Double hinge  
Pitch 1 ½" (38,1 mm)  
Thickness 4,8 mm (0.189")  
Hinge 136,5 mm (5.374")

**Page 105**

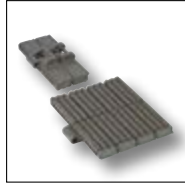

**LBP 8257**  
Straight running  
Heavy duty single hinge  
Pitch 1 ½" (38,1 mm)  
Thickness 4,8 mm (0.189")  
Hinge 57 mm (2.244")

**Page 106**



**LBP 882T**  
Sideflexing TAB  
Heavy duty single hinge  
Pitch 1 ½" (38,1 mm)  
Thickness 4,8 mm (0.189")  
Hinge 57 mm (2.244")

**Page 107**



**LBP 882M**  
Sideflexing Magnetic  
Heavy duty single hinge  
Pitch 1 ½" (38,1 mm)  
Thickness 4,8 mm (0.189")  
Hinge 57 mm (2.244")

**Page 108**

**BIPLANAR CHAINS**



**1700**  
Sideflexing  
Increased product  
support surface  
Pitch 1.97" (50 mm)  
Thickness 4 mm (0.157")

**Page 111**

**NEW**



**1710**  
Zero Gap  
Pitch 1.97" (50 mm)  
Thickness 6 mm (0.236")

**Page 112**



**Turning disc**  
For 1700 Series

**Page 113**



**1702**  
Sideflexing  
Pitch 1.97" (50 mm)  
Thickness 5 mm (0.197")

**Page 114**

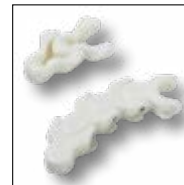

**1701T**  
Sideflexing TAB  
Pitch 1.97" (50 mm)  
Thickness 5 mm (0.197")

**Page 115**

**SPROCKETS FOR CHAINS**



**Page 119**

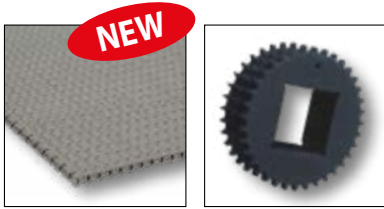

**8300**  
Solid Top  
Imperial width standard  
Thickness 6,15 mm (0.242")

Page 163

**Sprockets**  
8300 series

Page 164

½" PITCH BELTS AND CHAINS

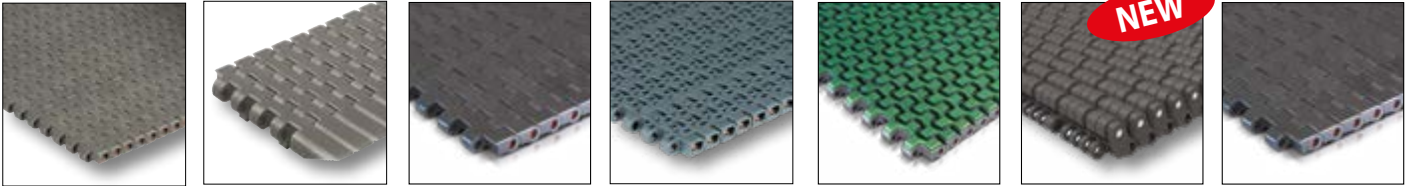

**600**  
Solid top  
Flat bottom surface  
Metric width standard  
Thickness 8,7 mm (0.343")

Page 169

**600G ATM**  
Active transfer modules  
Solid top  
Metric width standard  
Thickness 8,7 mm (0.343")

Page 171

**610**  
Solid top  
Round bottom surface  
Metric width standard  
Thickness 8,7 mm (0.343")

Page 172

**500**  
Flush grid  
Metric width standard  
Thickness 8,7 mm (0.343")

Page 174

**HF 510**  
Rubberized surface  
Metric width standard  
Thickness 8,7 mm (0.343")

Page 175

**LBP 610**  
LBP rollers  
Metric width standard  
Thickness 8,7 mm (0.343")

Page 177

**300**  
Solid Top  
Imperial width standard  
Thickness 8,7 mm (0.343")

Page 178

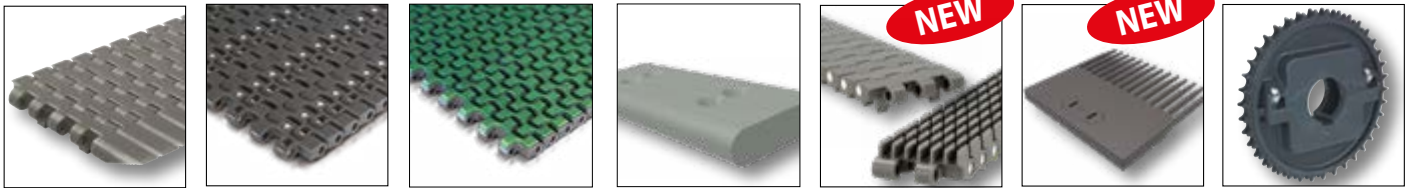

**300G ATM**  
Active transfer modules  
Solid top  
Imperial width standard  
Thickness 8,7 mm (0.343")

Page 179

**200**  
Flush grid  
Imperial width standard  
Thickness 8,7 mm (0.343")

Page 180

**HF 200**  
Rubberized surface  
Imperial width standard  
Thickness 8,7 mm (0.343")

Page 181

**Nosebar**  
For ½" pitch belts with  
metric and imperial width  
standard

Page 182

**611 / RR 611**  
Narrow chains  
Solid top (611)  
Raised Rib (RR 611)  
Thickness 8,7 mm (0.343")

Page 184

**Transfer combs**  
For RR 611 belts

Page 186

**Sprockets**  
611 series  
600 series

Page 187

1" PITCH LIGHT DUTY BELTS AND CHAINS



**1600**  
Solid top  
Metric width standard  
Thickness 8,7 mm (0.343")

Page 196

**1600G ATM**  
Active transfer modules  
Solid top  
Metric width standard  
Thickness 8,7 mm (0.343")

Page 198

**1500**  
Flush grid  
Metric width standard  
Thickness 8,7 mm (0.343")

Page 199

**1500G ATM**  
Active transfer modules  
Flush grid  
Metric width standard  
Thickness 8,7 mm (0.343")

Page 201

**1600 & 1500 with flights**

Page 202

**RR 1500**  
Raised rib  
Metric width standard  
Thickness 8,7 mm (0.343")

Page 204

**Transfer combs**  
For RR 1500 belts

Page 205

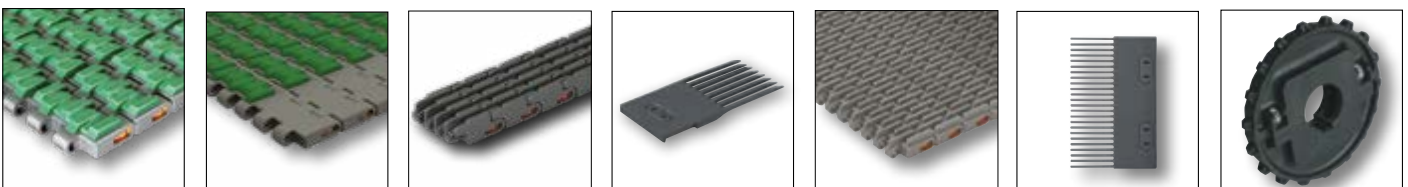

**HF 1600**  
Rubberized surface  
Metric width standard  
Thickness 8,7 mm (0.343")

Page 206

**HFS 1600**  
Rubberized surface  
Side indent  
Metric width standard  
Thickness 8,7 mm (0.343")

Page 207

**RR 1600**  
Dedicated chains  
Raised rib  
Metric width standard  
Thickness 8,7 mm (0.343")

Page 208

**Transfer combs**  
For RR 1600 chains

Page 209

**1110**  
Raised rib  
Imperial width standard  
Thickness 9,6 mm (0.378")

Page 210

**Transfer combs**  
For 1110 belts

Page 211

**Sprockets**  
1010 series

Page 212

## 3/4" PITCH MEDIUM DUTY BELTS AND CHAINS

**Matveyor®**

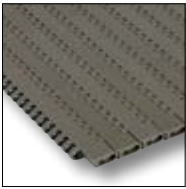

**7300**  
Solid top  
Imperial width standard  
Thickness 8,7 mm (0.343")

**Page 221**

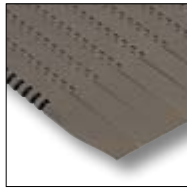

**7300G ATM**  
Active transfer modules  
Solid top  
Imperial width standard  
Thickness 8,7 mm (0.343")

**Page 223**

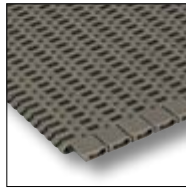

**7200**  
Flush grid  
Imperial width standard  
Thickness 8,7 mm (0.343")

**Page 224**



**Sprockets**  
7300 series

**Page 226**

## 1" PITCH HEAVY DUTY BELTS AND CHAINS

**Matveyor®**



**USPM**  
Solid top  
Metric width standard  
Thickness 12,7 mm (0.500")

**Page 231**

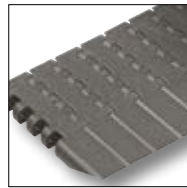

**USPMG ATM**  
Active transfer modules  
Solid top  
Metric width standard  
Thickness 12,7 mm (0.500")

**Page 233**

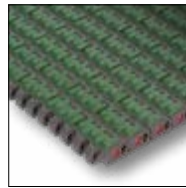

**HF USPM**  
Rubberized surface  
Metric width standard  
Thickness 12,7 mm (0.500")

**Page 234**

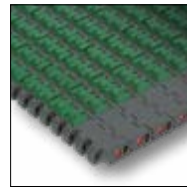

**HFS USPM**  
Rubberized surface  
Side indent  
Metric width standard  
Thickness 12,7 mm (0.500")

**Page 235**

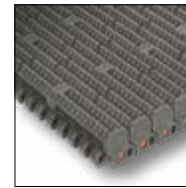

**LBP USPM**  
LBP rollers  
Metric width standard  
Thickness 12,7 mm (0.500")

**Page 236**

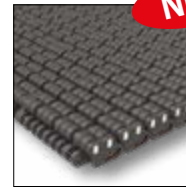

**LBP XSPM**  
LBP rollers  
Safety design  
Metric width standard  
Thickness 11 mm (0.433")

**Page 237**

**NEW**

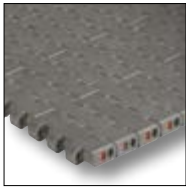

**USP**  
Solid top  
Imperial width standard  
Thickness 12,7 mm (0.500")

**Page 238**

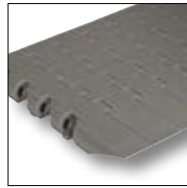

**USPG ATM**  
Active transfer modules  
Solid top  
Imperial width standard  
Thickness 12,7 mm (0.500")

**Page 240**



**Sprockets**  
USP series

**Page 241**

## 1" PITCH SIDEFLEXING CHAINS

**Matveyor®**



**783T**  
TAB  
Solid top  
For light duty belts  
Thickness 8,7 mm (0.343")

**Page 246**

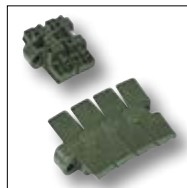

**783M**  
Magnetic  
Solid top  
For light duty belts  
Thickness 8,7 mm (0.343")

**Page 247**

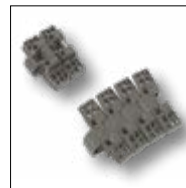

**782M**  
Magnetic  
Flush grid  
For light duty belts  
Thickness 8,7 mm (0.343")

**Page 247**

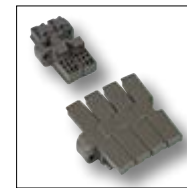

**793T**  
TAB  
Solid top  
For heavy duty belts  
Thickness 12,7 mm (0.500")

**Page 248**



**793M**  
Magnetic  
Solid top  
For heavy duty belts  
Thickness 12,7 mm (0.500")

**Page 249**



**793L**  
Low Pin Center  
Solid Top  
For heavy duty belts  
Thickness 12,7 mm (0.500")

**Page 250**

**NEW**



**Sprockets**  
782 series

**Page 251**



**1 1/4" PITCH HEAVY DUTY SIDEFLEXING BELTS**

**Matveyor®**

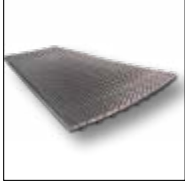

**2556HTB**

TAB+Bearing  
Reinforced outer module  
Metric width standard  
Thickness 12,7 mm (0.500")

**Page 255**

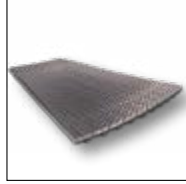

**2556HTB-SR**

TAB+Bearing  
Reinforced outer module  
Reduced sideflexing radius  
Metric width standard  
Thickness 12,7 mm (0.500")

**Page 256**



**Sprockets**

2556 series

**Page 257**

**2" PITCH HEAVY DUTY RAISED RIB BELTS**

**Matveyor®**



**3125**

Raised rib  
Seamless product support  
at the edges of the belt  
Imperial width standard  
Thickness 14,2 mm (0.580")

**Page 265**

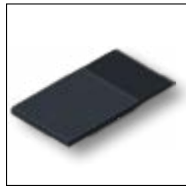

**Transfer  
combs**

For 3125 belt

**Page 266**



**Sprockets**

3000 series

**Page 268**

**1 1/2" PITCH HEAVY DUTY UCC CHAINS**

**ULTOP®**



**UCC**

Solid top  
Imperial width standard  
Thickness 12,7 mm (0.500")

**Page 272**

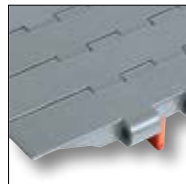

**UCCG ATM**

Active transfer modules  
Solid top  
Imperial width standard  
Thickness 12,7 mm (0.500")

**Page 273**



**UCC 138**

3/4" Pitch  
Solid top  
Imperial width standard  
Thickness 15 mm (0.591")

**Page 274**



**Sprockets**

UCC series  
UCC138 series

**Page 275**

## CORNER TRACKS

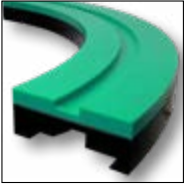

### Magnetic curves

For FliteTop® and Matveyor® chains

Page 280



### TAB curves

For FliteTop® chains and Matveyor® sideflexing belts and chains

Page 320



### Bevel curves

For FliteTop® chains

Page 325

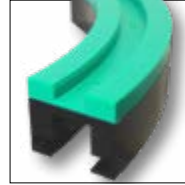

### Low Pin Center curves

For Matveyor® chains

Page 328

## CONVEYOR COMPONENTS

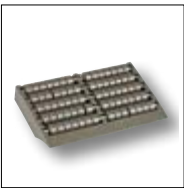

### Modular transfer plates

For FliteTop® chains and Matveyor® belts

Page 331



### Return rollers

For FliteTop® chains, Matveyor® belts and chains, ULTOP® chains

Page 332



### Guide flanges

For FliteTop® chains, Matveyor® belts and chains, ULTOP® chains

Page 334



### Return shoe guide

For FliteTop® LBP chains and Matveyor® LBP belts

Page 334

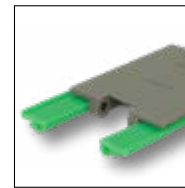

### Wear strips

For FliteTop® chains, Matveyor® belts and chains, ULTOP® chains

Page 335



### Product side guides

Page 341







**STEEL AND THERMOPLASTIC CHAINS, MODULAR BELTS**

	Type	Description	Features
<b>STEEL</b>	S	<b>Carbon Steel</b>	Through hardened carbon steel. Surface and core hardness of 43 HRC. Excellent strength and wear resistance. Not suitable in presence of water.
	SS - 4	<b>Ferritic Stainless Steel</b>	Cold rolled ferritic stainless steel. Good wear, mechanical and corrosion resistance. For food & beverage applications.
	P	<b>PRIMA Superior Grade Ferritic Stainless Steel</b>	Superior grade of cold rolled special ferritic stainless steel. Special Cr-Ni alloy offering very good wear and mechanical properties. Particularly suitable for high productivity lines (combiners and inliners).
	SS	<b>Austenitic Stainless Steel</b>	Cr-Ni austenitic cold rolled stainless steel. It guarantees the best corrosion resistance to withstand chemical attack. It offers very good wear resistance, due to work hardening and homogeneous chemical structure.
<b>ACETAL POM</b>	WA <i>White</i>	<b>White Acetal</b>	DuPont™ Delrin® homopolymer acetal resin.
	UP <i>Dark Brown</i>	<b>Ultra Performance Homopolymer Delrin®</b>	DuPont™ Delrin® Ultra Performance special homopolymer acetal resin. Particularly suitable for applications where low coefficient of friction and contained dusting are needed.
	DK2™ <i>Dark Green</i>	<b>Special Delrin® Reinforced with Kevlar®</b>	<b>Next generation material, based on a Delrin® acetal resin reinforced with Kevlar®,</b> developed by REGINA and DuPont™, able to reach the lowest coefficient of friction with maximum wear resistance. Thanks to the superior properties of <b>DK2™</b> , the usage of lubricants can be drastically reduced or even eliminated without losing performance in conveyor applications.
	<b>NEW</b> <b>e-FAST.</b> <i>Yellow</i>	<b>Ecological Friction Abating Thermoplastic</b>	Ultimate dry running homopolymer acetal resin developed combining REGINA field expertise with DuPont™ centenarian acetal resin knowledge. Today's standards for high performance filling lines require a combination of high speed and high productivity, while reducing or eliminating lubrication. REGINA <b>e-FAST.</b> material is capable of exceeding such standards, thanks to its unique characteristic of delivering a much lower and constant coefficient of friction over time in dry or almost dry running conditions vs. other plastic chains.
	AS <i>Black</i>	<b>Antistatic Acetal Resin</b>	Conductive acetal resin particularly suitable for all applications where static charges on the chain must be avoided.
<b>POLYAMIDE</b>	AR <i>Black</i>	<b>Abrasion Resistance Polyamide</b>	Suitable for glass manufacturing applications. Reinforced polyamide with excellent wear resistance and low dusting. Only for dry running applications.
<b>POLYPROPYLENE</b>	P <i>Light Blue</i>	<b>Reinforced Polypropylene</b>	For FliteTop® Chains. Reinforced polypropylene that guarantees the best corrosion resistance to withstand chemical attack and an optimum high temperature resistance.
	PP <i>Grey</i>	<b>Special Polypropylene</b>	For Matveyor® Belts. Special polypropylene that guarantees the best corrosion resistance to withstand chemical attack and an optimum high temperature resistance.
<b>POLYESTER</b>	ULF <i>Light Grey</i>	<b>Ultra Low Friction Polyester Resin</b>	Polyester resin that offers good mechanical strength in combination with low coefficient of friction.





DuPont™ Delrin® and DuPont™ Kevlar® are registered trade marks of E.I. DuPont De Nemours and Associates.





## RUBBERS

Type	Description	Features
<b>RUBBER</b>      	<b>NBR Rubber</b>	NBR Rubber with hardness of 70 ShA, applied on stainless steel chains, guarantees an excellent product grip on inclined/declined conveyors, high wear resistance and superior resistance against sanitizers ordinary used in bottling industries.
	<b>Thermoplastic Rubber</b>	Special Thermoplastic rubber with hardness from 50 ShA up to 70 ShA and optimum wear resistance that guarantees exceptional product grip in inclined/declined conveyors and elevators/lowerators, extending life without losing elasticity.
	<b>Heat Stabilized Thermoplastic Rubber</b>	Special Thermoplastic rubber resistant to high temperatures, with hardness from 45 ShA to 70 ShA, for rinsers and cap sterilizer applications.
	<b>EPDM Rubber</b>	For gripper chain series. EPDM rubber with hardness of 60 ShA guarantees an excellent grip and high temperature resistance.





## BASE ROLLER CHAINS

Type	Description	Features
<b>STEEL</b>    	<b>Carbon Steel</b>	Through hardened carbon steel. Excellent strength and wear resistance.
	<b>Stainless Steel</b>	Stainless Steel for the best corrosion resistance to withstand chemical attack. Prelubricated with high performance lube suitable for the food industry (USDA H1 approved) which guarantees long-lasting effect for the chain.
	<b>Maintenance free carbon steel</b>	For "lube-free" applications. ENDURO maintenance free chains outlast standard chains without periodic lubrication. The unique technology and "heavy wall" design of the sintered bushing ensures excellent wear resistance.
	<b>Carbon Steel Nickel Plated</b>	Through hardened carbon steel and electroless nickel plating for good corrosion resistance. Excellent strength and wear resistance.

## SPROCKETS AND TURNING DISCS

Type	Description	Features
POLYAMIDE	 <p><b>PA</b> Black</p>	<p><b>Polyamide</b></p> <p>For sprockets. Machined polyamide that guarantees toughness combined with wear and abrasion resistance.</p>
	 <p><b>PGF</b> Black</p>	<p><b>Reinforced Polyamide</b></p> <p>For sprockets and turning discs. Moulded polyamide reinforced with glass fibers allowing higher strength and excellent abrasion resistance.</p>
ACETAL POM	 <p><b>WA</b> White</p>	<p><b>White Acetal</b></p> <p>For sprockets 3000 series. DuPont™ Delrin® homopolymer acetal resin.</p>

## CURVES AND STATIC NOSEBAR

Type	Description	Features
POLYETHYLENE	 <p><b>SUPREME -A</b> Green</p>	<p><b>UHMWPE</b></p> <p>For Magnetic and Low Pin Center curves. Ultra high molecular weight polyethylene (about 7 milion gr/mole) with good wear resistance and low coefficient of friction.</p>
	 <p><b>SUPREME -L</b> Grey</p>	<p><b>Self-Lubricating UHMWPE</b></p> <p>For Magnetic, TAB, Bevel, Low Pin Center curves and for ½" pitch belts nosebar. High grade of ultra high molecular weight polyethylene (about 7-9 milion gr/mole) with optimum wear and abrasion resistance, combined with advanced lubricant for excellent sliding properties.</p>
	 <p><b>UHMWPE</b> Black</p>	<p><b>UHMWPE</b></p> <p>For Bevel and TAB curves. Ultra high molecular weight polyethylene with good wear and abrasion resistance.</p>
POLY AMIDE	 <p><b>SUPREME -S</b> Yellow</p>	<p><b>Oil-Filled PA</b></p> <p>For Magnetic, TAB, Bevel and Low Pin Center curves. Special high grade and oil-filled polyamide, with superior abrasion resistance and extremely high PV limit. Dry running only.</p>

CONVEYOR COMPONENTS

	Type	Description	Features
ACETAL POM	DG <i>Dark Grey</i>	Acetal Resin	For combs. Good wear resistance and low coefficient of friction.
POLYETHYLENE	HDPE <i>Black</i>	High Density Polyethylene	For return rollers, product side guide and shoe guide. High density polyethylene with low coefficient of friction and good wear resistance.
	HDPE <i>Grey</i>		
	HDPE <i>Green</i>		
	UHMWPE <i>Green</i>	UHMWPE	For wear strips. Ultra high molecular weight polyethylene with reduced coefficient of friction and high wear resistance.
	UHMWPE <i>Black</i>		
POLYPROPYLENE	PP <i>Black</i>	Polypropylene	For guide flanges. Lightweight material that offers optimum chemical and high temperature resistance.



Developed with and on the market for 20 years, **DK<sup>2</sup>** is a lubricated acetal resin reinforced with Kevlar<sup>®</sup> that combines a **low coefficient of friction** with a **very high wear resistance**, resulting in longer chain life and running-cost savings.

COF IN DRY RUNNING CONDITIONS\*

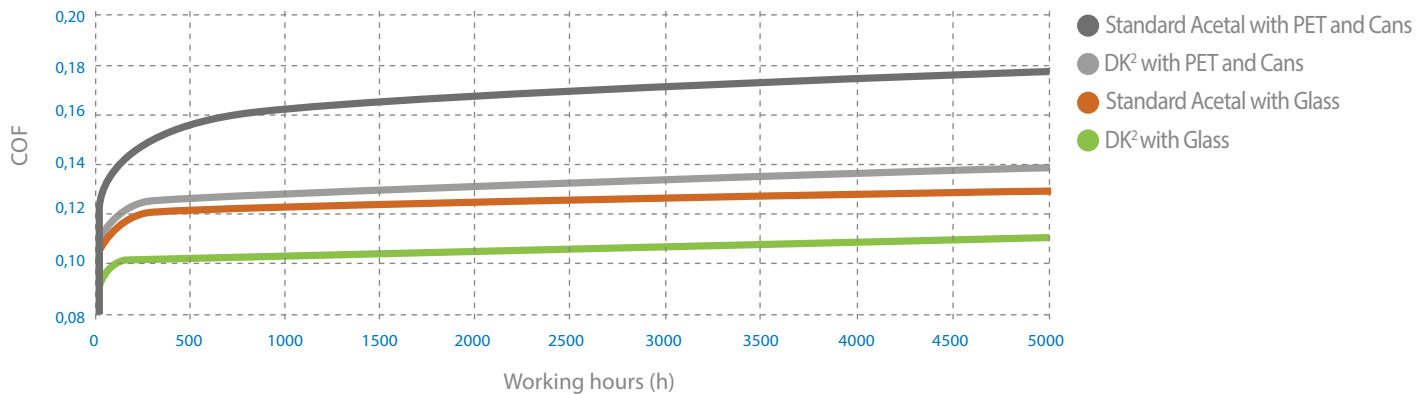

WEAR IN DRY RUNNING CONDITIONS\*

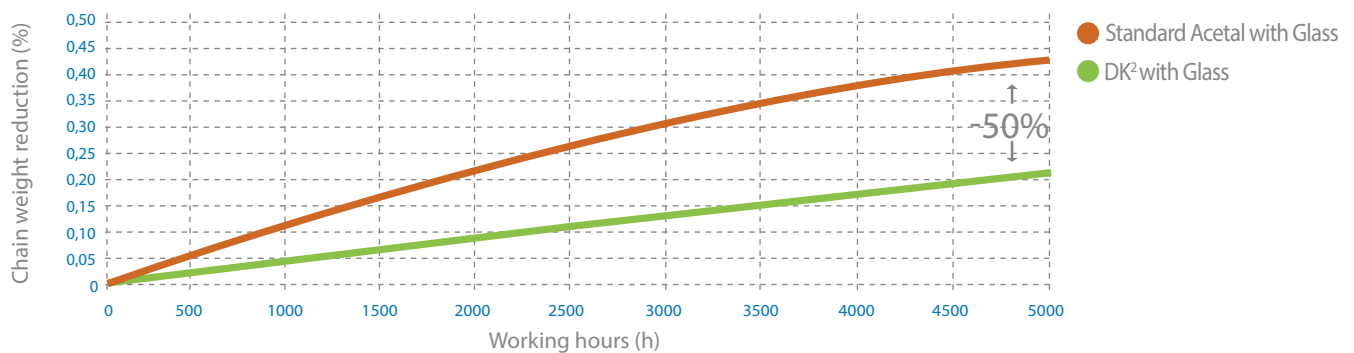

### FEATURES

- Excellent for PET, Can and Glass applications
- Lower coefficient of friction in dry running conditions vs. standard acetal resin
- 30-50% superior wear resistance in dry running conditions vs. standard acetal resin (depending on container material)

### BENEFITS

- Significant reduction or elimination of lubrication, leading to:
  - Less lube "build-up"
  - Reduction of motor power absorption
  - Longer center to center distances
- Very significant chain life increase vs. standard acetal resins
- Lower running and maintenance costs vs. standard acetal resins

\*Coefficient of friction and wear data measured in actual field tests



# e-F.A.S.T.

FRICION ABATING SLIDING THERMOPLASTIC

Developed with , **e-F.A.S.T.** is the ultimate dry running acetal resin compounded with specific lubricants for PET bottling applications, able to deliver a **much lower and constant coefficient of friction** and **minimal elongation** over time in **dry running conditions** vs. other plastic chains.

**NEW FOR PET BOTTLES**

COF IN DRY RUNNING CONDITIONS\*

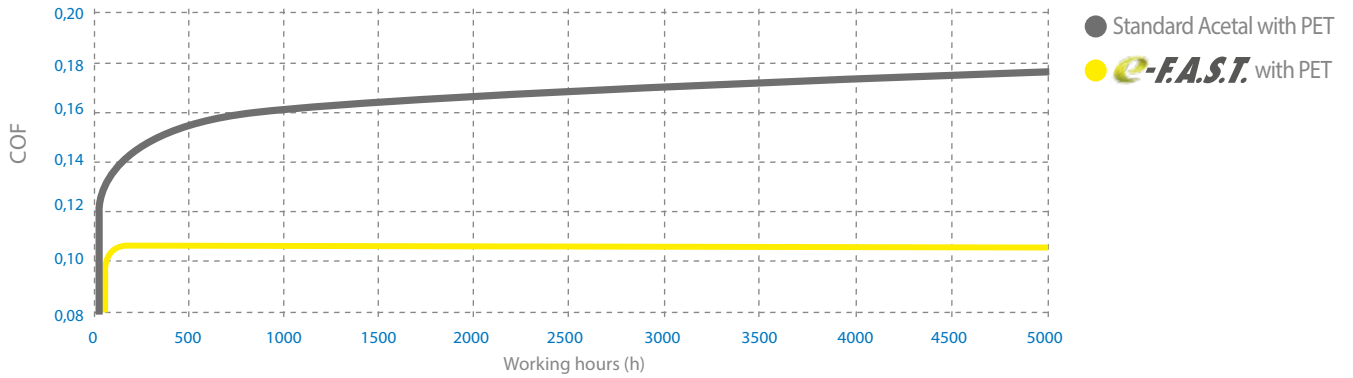

WEAR IN DRY RUNNING CONDITIONS\*

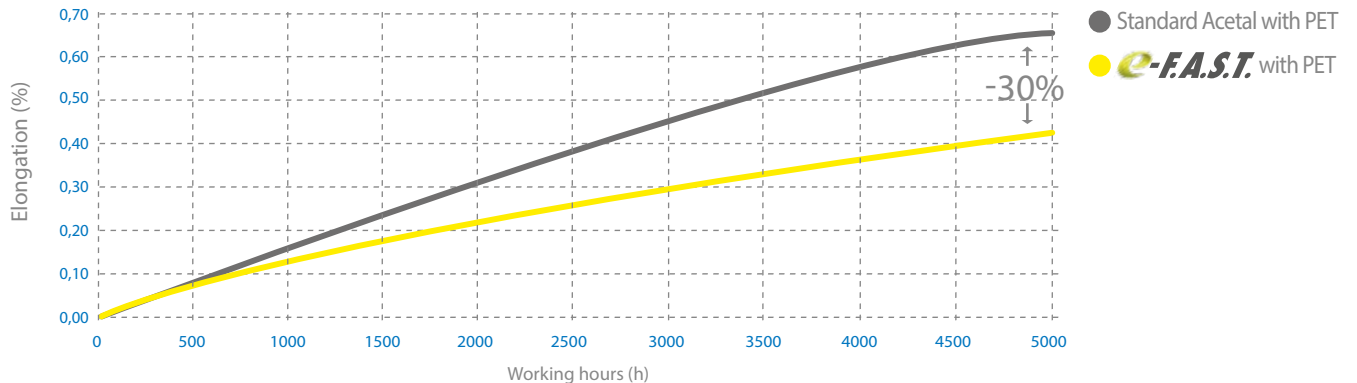

### FEATURES

- Lowest coefficient of friction in PET dry running applications
- Long lasting and constant coefficient of friction
- Negligible dusting in dry running conditions
- Bright chain color



























### BENEFITS

- Elimination or strong reduction of lubrication
- Reduced chain pull and increased energy savings
- Increased chain life
- Reduced maintenance costs
- Due to bright color, easy identification of conveyor cleaning needs

\*Coefficient of friction and wear data measured in actual field tests





The materials used by REGINA can be applied in the range of temperatures stated in the following tables.

**TABLE "A"**

	MATERIAL	USED FOR	MIN. TEMPERATURE		MAX. TEMPERATURE			
					DRY ENVIRONMENT		WET ENVIRONMENT	
			°C	°F	°C	°F	°C	°F
STEEL	CARBON STEEL 	CHAINS	-30	-22	+371	+700	-	-
	FERRITIC STAINLESS STEEL  	CHAINS	-40	-40	+427	+800	+427	+800
	AUSTENITIC STAINLESS STEEL 	CHAINS	-40	-40	+538	+1000	+538	+1000
PLASTIC	ACETAL RESIN      	CHAINS/BELTS/SPROCKETS/COMBS	-40	-40	+80	+176	+65	+149
	POLYPROPYLENE   	CHAINS/BELTS/COMPONENTS	0	32	+104	+220	+104	+220
	ABRASION RESISTANT POLYAMIDE* 	CHAINS/BELTS	-40	-40	+100	+212	-	-
	POLYESTER RESIN 	CHAINS/BELTS	+4	+39	+80	+176	+65	+149
	POLYAMIDE  	SPROCKETS/TURNING DISCS	-20	-4	+120	+248	+120	+248
	POLYETHYLENE        	CURVES/NOSEBAR/COMPONENTS	-40	-40	+80	+176	+80	+176
POLYAMIDE* 	CURVES	-40	-40	+100	+212	-	-	

\* For dry running applications only.

**TABLE "B"**

RUBBER MATERIAL	COLOUR	AVERAGE HARDNESS	MIN. TEMPERATURE		MAX. TEMPERATURE				NOT SUITABLE WITH	RESISTANT TO
					DRY ENVIRONMENT		WET ENVIRONMENT			
			ShA	°C	°F	°C	°F	°C		
NBR 	BLACK	70	-10	+14	+110	+230	+80	+176	STRONG ACIDS AND BASES	OILS
EPDM 	BLACK	60	-30	-22	+120	+248	+120	+248	OILS	WEAK ACIDS
THERMOPLASTIC  	GREEN/GREY	50-70	-40	-40	+80	+176	+80	+176	OILS	WEAK ACIDS
HEAT STABILIZED THERMOPLASTIC 	GREY	45-70	-30	-22	+130	+266	+130	+266	OILS	HIGH TEMPERATURES

It is important to choosing the right material for FliteTop<sup>®</sup>, Matveyor<sup>®</sup> and ULTOP<sup>®</sup> chains and belts according to possible chemicals used in application. As a guide TABLE "C" shows the performance of FliteTop<sup>®</sup>, Matveyor<sup>®</sup> and ULTOP<sup>®</sup> chains/belts materials with various chemicals. For chemicals not listed in TABLE "C", please contact our Technical Service group for advice.

**TABLE "C"**

CHEMICAL AGENT	CARBON STEEL	AUSTENITIC STAINLESS STEEL	FERRITIC STAINLESS STEEL		ACETAL RESIN		POLYPROPYLENE		ABRASION RESISTANT POLYAMIDE	POLYESTER RESIN
	S	SS	SS-4	P	AS	UP	P	PP	AR	ULF
ACETIC ACID 5%	-	*	-	-	-	-	*	*	+	*
ACETONE	-	*	*	*	+	*	*	*	*	+
ALCOHOL	*	*	*	*	*	*	*	*	*	*
AMMONIA CONC.	+	*	*	*	-	*	*	*	*	+
AMMONIA WATER SOL.	+	*	*	*	*	*	*	*	*	*
ANILINE 3%	/	/	/	/	*	*	*	*	/	+
AQUA REGIA	-	-	-	-	-	+	+	+	/	/
BEER	+	*	*	*	*	*	*	*	*	*
BENZENE	*	*	*	*	*	*	*	*	*	-
BENZOL	*	*	*	*	*	*	*	*	*	+
BRINE ACID	-	+	-	-	+	*	*	*	+	*
BUTYRIC ACID	*	*	*	*	-	*	*	*	-	/
CARBON TETRACHLORIDE	+	+	+	+	*	-	*	*	*	/
CHLORINE WATER	-	+	+	+	-	*	*	*	-	-
CHOCOLATE	+	*	*	*	-	+	+	+	-	+
CITRIC ACID	-	*	+	+	+	*	*	*	+	+
FORMALDEHYDE	*	*	*	*	*	*	*	*	*	*
FORMIC ACID 10%	-	-	-	-	-	*	*	*	-	+
FRUIT JUICE	-	*	+	+	*	*	*	*	*	*
GASOLINE	*	*	*	*	*	+	+	+	*	+
GRAPE HUSK	-	+	-	-	-	*	*	*	-	+
HYDROCHLORIC ACID 2%	-	-	-	-	-	*	*	*	-	+
HYDROCHLORIC ACID 37%	-	-	-	-	-	*	*	*	-	-
HYDROGEN PEROXIDE	-	*	+	+	-	*	*	*	-	+
IODINE	-	-	-	-	-	-	-	-	-	-
LACTIC ACID	-	*	+	+	*	*	*	*	+	*
MILK	*	*	*	*	*	*	*	*	*	*
MUSTARD	*	*	*	*	-	+	+	+	-	+
NITRIC ACID 5%	-	*	*	*	-	*	*	*	-	+
OIL	*	*	*	*	*	-	-	-	-	*
OIL (VEGETABLE & MINERAL)	*	*	*	*	*	*	*	*	*	*
PARAFFIN	*	*	*	*	*	*	*	*	*	*
PHOSPHORIC ACID %	-	*	+	+	-	*	*	*	-	-
SEA WATER	-	+	-	-	+	*	*	*	-	*
SOAP & WATER	+	*	*	*	*	*	*	*	*	*
SODIUM CHLORIDE	-	+	-	-	*	*	*	*	*	*
SODIUM HYDROXIDE 25%	-	*	*	*	-	*	*	*	/	-
SODIUM HYPOCHLORITE	-	+	-	-	-	*	*	*	*	+
SOFT DRINKS	+	*	*	*	*	*	*	*	*	*
SPIRITS	*	*	*	*	*	*	*	*	*	*
SULPHURIC ACID 40%	-	-	-	-	-	*	*	*	-	+
TOLUENE	/	/	/	/	+	+	+	+	/	+
TURPENTINE	*	*	*	*	/	*	*	*	/	*
VEGETABLE JUICE	+	*	*	*	*	*	*	*	*	*
WATER	-	*	*	*	*	*	*	*	*	*
WINE	*	*	*	*	*	*	*	*	*	*
XYLOL	/	/	/	/	/	/	/	/	/	/

**LEGEND**  
 \*=SATISFACTORY  
 +=MARGINAL  
 -=UNSATISFACTORY  
 /=UNDETERMINED

Data shown in the table was taken from laboratory tests performed on unstrained samples and are merely indicative. Chemical resistance under normal working conditions can depend on various factors, such as stress and temperature, concentration of the chemical agent and duration of its effects.

# FliteTop<sup>®</sup> CHAINS

CONVEYED  
PRODUCTS

**PRODUCTS**

**STEEL CHAINS**

Carbon Steel	<input type="checkbox"/>	Ferritic	<input type="checkbox"/>	Austenitic	<input type="checkbox"/>	PHD Series*	Rubberized Series
	S	SS-4	P	SS			NR

FOOD / BEVERAGE / BOTTLING APPLICATIONS	CONVEYED PRODUCTS	APPLICATIONS	PRODUCTS				
			Carbon Steel	Ferritic	Austenitic	PHD Series*	Rubberized Series
FOOD / BEVERAGE / BOTTLING APPLICATIONS	CANS (2-3 PIECES)	Depalletizer					
		Inliner/combiner					
		Mass conveyors					
		Accumulation tables					
		Sterilizers / Rinsers Elevators / Lowerators					
		Infeed packaging machines					
		Packaging machines					
		Packaged products convey					
		Inclined conveyors					
	PET BOTTLES	Inliner/combiner					
		Mass conveyors					
		Accumulation tables					
		Sterilizers / Rinsers Elevators / Lowerators					
		Infeed packaging machines					
		Packaging machines					
		Packaged products convey					
		Inclined conveyors					
		GLASS BOTTLES**	Depalletizer				
	Inliner/combiner						
	Mass conveyors						
	Accumulation tables						
	Sterilizers / Rinsers Elevators / Lowerators						
	Infeed packaging machines						
	Packaging machines						
	Packaged products convey						
	Inclined conveyors						
	GLASS MFG.	GLASS BOTTLES	Inliner/combiner				
Mass conveyors							
Accumulation tables							
Palletizer							
Omega / Blowing Machines							
SPECIAL APPLICATIONS	AUTOMOTIVE / MECHANICAL IND.	Conveyors lines					
	CHEMICAL, DETERGENTS, PHARMACEUTICAL AND COSMETICS IND.	Conveyors lines					
	DAIRY IND.	Conveyors lines					

\* PHD Series features PRIMA material plates and hardened martensitic stainless steel pins.

\*\* In case of returnable glass bottles, please contact REGINA Application Engineers.





CONVEYED PRODUCTS		<b>Matveyor® ULTOP®</b> <b>CHAINS/ BELTS</b>	PRODUCTS							
			NANOPITCH ( 8mm)	LIGHT DUTY SHORT PITCH ( ½")				LIGHT DUTY (1" PITCH)		
			8300	600 610 300	500 200	HF 510 HF 200	611 RR611	LBP610	1600	1500
FOOD / BEVERAGE / BOTTLING APPLICATIONS	CANS (2-3 PIECES)	Depalletizer								
		Inliner/combiner								
		Mass conveyors								
		Accumulation tables								
		Warmer								
		Infeed packaging machines								
		Packaging machines								
		Packaged products convey								
	PET BOTTLES	Inliner/combiner								
		Mass conveyors								
		Accumulation tables								
		Warmer								
		Infeed packaging machines								
		Packaging machines								
		Packaged products convey								
	GLASS BOTTLES	Depalletizer								
		Inliner/combiner								
		Mass conveyors								
		Accumulation tables								
		Pasteurizer								
		Infeed packaging machines								
		Packaging machines								
		Packaged products convey								
	GLASS MFG.	GLASS BOTTLES	Inliner/combiner							
			Mass conveyors							
			Accumulation tables							
			Palletizer							
	SPECIAL APPLICATIONS	PHARMACEUTICAL DETERGENT COSMETICS CONTAINERS	Conveyors lines							
BAKERY		Conveyors lines								
PAPER/ CARDBOARD		Conveyors lines								





**PERFORMANCE IN MOTION**







PERFORMANCE IN MOTION

***FliteTop***<sup>®</sup>

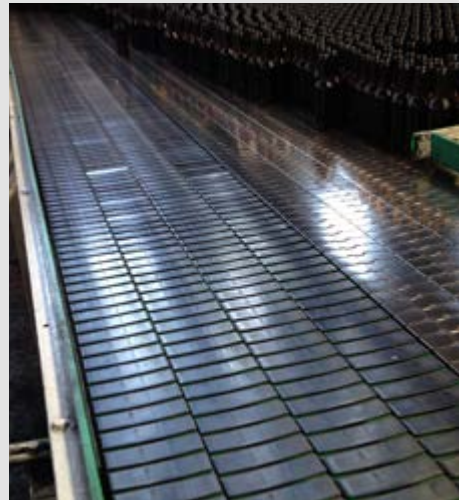



PERFORMANCE IN MOTION

***FliteTop***<sup>®</sup>  
Steel Chains

## INDUSTRIES AND APPLICATIONS

### STAINLESS STEEL CHAINS

Suitable for handling: new glass and returnable glass containers, kegs, crates.

#### INDUSTRIES

Bottling and canning  
Food filling  
Glass manufacturing  
Consumer goods

#### APPLICATIONS

Depalletizer  
Inliner / combiner  
Mass conveyors  
Accumulation tables  
Infeed / outfeed packaging machines  
Packaged product convey



### CARBON STEEL CHAINS

Suitable for handling: new glass & metal containers, abrasive components.

#### INDUSTRIES

Glass manufacturing  
Automotive / Mechanical

#### APPLICATIONS

Inliner / combiner  
Mass conveyors  
Accumulation tables  
Pallettizer



## FEATURES

- Premium surface finishing and flatness.
- PRIMA material available (REGINA Cr-Ni based SS special alloy) with improved wear resistance and sliding properties, suitable for high speed bottling lines.
- Hardened pin available (PHD series) for the highest resistance to chain elongation over a long period of time.

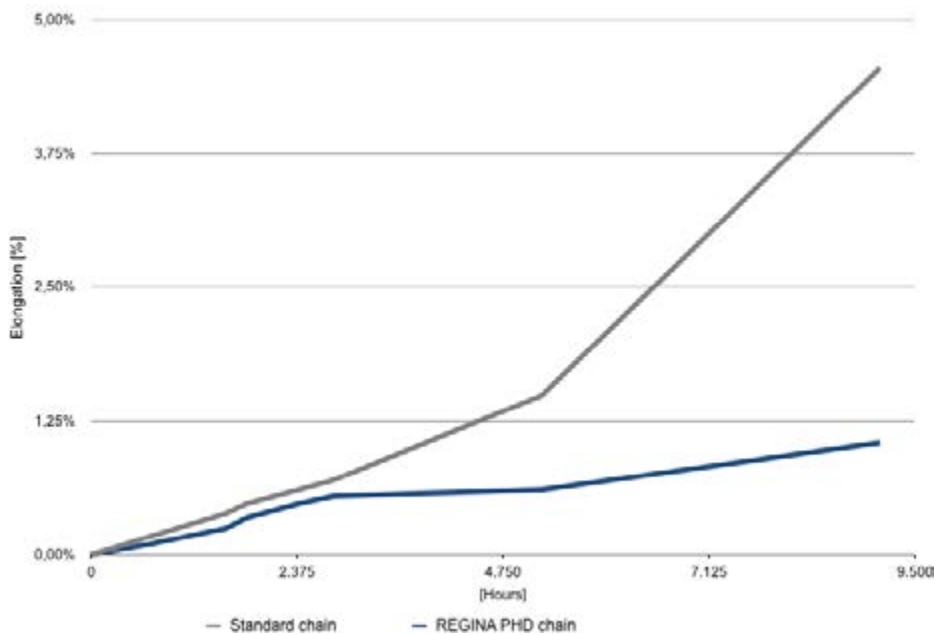

### Application conditions

Product conveyed: glass returnable  
Test area: uncaser  
Dirty environment  
Lubrication: water and soap  
Conveyor length: 5 mt  
Chain speed: 21 m/1' (60.000 b/h)



## SINGLE HINGE

REDUCED PLATE GAP 1,6 mm

INCREASED PIN HARDNESS (PHD 915 SERIES)

SPECIAL XPHD CHAINS FOR PRESSURELESS COMBINERS **NEW**

PITCH 1 ½" (38,1 mm)

THICKNESS 3 mm (0.118")

HINGE 42 mm (1.654")

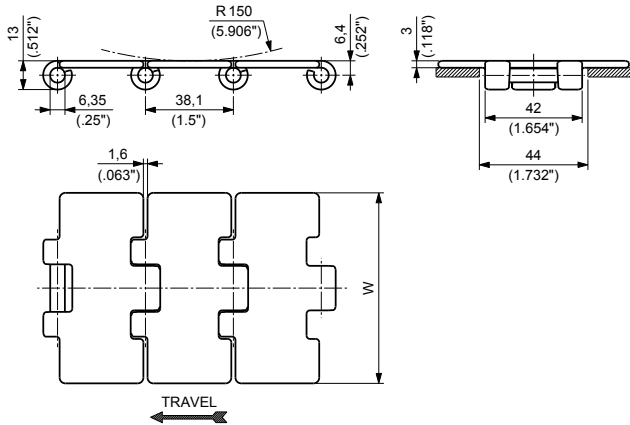

### 915



Materials  
see page 12



Sprockets  
see pages 120÷127



Applications  
see page 20

MATERIALS		ITEM DESCRIPTION	PART NUMBER	WIDTH W		SURFACE FINISH Ra	POLISHED HINGES	YIELD LOAD AVERAGE		WEIGHT	
Plate	Pin			mm	inch			N	lbs	kg/m	lbs/ft
PRIMA P	AUSTENITIC STAINLESS STEEL	P 915 K 2 ¼	P915KS/000	57,1	2.25	0,3	NO	8500	1,913	2,00	1.34
		P 915 K 2 ½	P915KR/000	63,5	2.50	0,3	NO	8500	1,913	2,14	1.44
		P 915 K 2 ⅝	P915KC/000	66,7	2.63	0,3	NO	8500	1,913	2,21	1.49
		P 915 K 3 ¼	P915KD/000	82,6	3.25	0,3	YES	8500	1,913	2,57	1.72
		P 915 K 83,8	P915KRA/000	83,8	3.30	0,3	YES	8500	1,913	2,60	1.75
		P 915 K 3 ½	P915KE/000	88,9	3.50	0,3	NO	8500	1,913	2,71	1.82
		P 915 K 4	P915KF/000	101,6	4.00	0,3	NO	8500	1,913	2,99	2.00
		P 915 K 4 ½	P915KG/000	114,3	4.50	0,3	NO	8500	1,913	3,28	2.20
		P 915 K 6	P915KH/000	152,4	6.00	0,3	NO	8500	1,913	4,13	2.78
		P 915 K 7 ½	P915KL/000	190,5	7.50	0,3	NO	8500	1,913	4,99	3.35

### PHD 915

MATERIALS		ITEM DESCRIPTION	PART NUMBER	WIDTH W		SURFACE FINISH Ra	POLISHED HINGES	YIELD LOAD AVERAGE		WEIGHT	
Plate	Pin			mm	Inch			N	lbs	kg/m	lbs/ft
PRIMA P	HARDENED MARTENSITIC STAINLESS STEEL	<b>NEW</b> XPHD 915 K 3 ¼	XPHD915KD/000	82,6	3.25	0,2	YES	8500	1,913	2,57	1.72
		<b>NEW</b> XPHD 915 K 83,8	XPHD915KRA/000	83,8	3.30	0,2	YES	8500	1,913	2,60	1.75
		PHD 915 K 4 ½	PHD915KG/000	114,3	4.50	0,3	NO	8500	1,913	3,28	2.20
		PHD 915 K 7 ½	PHD915KL/000	190,5	7.50	0,3	NO	8500	1,913	4,99	3.35



Standard packaging:  
Rolls of 3,048 m (10 feet)

## SINGLE HINGE

**REDUCED PLATE GAP (1,6 mm)**

**PITCH 1 ½" (38,1 mm)**

**THICKNESS 3 mm (0.118")**

**HINGE 42 mm (1.654")**

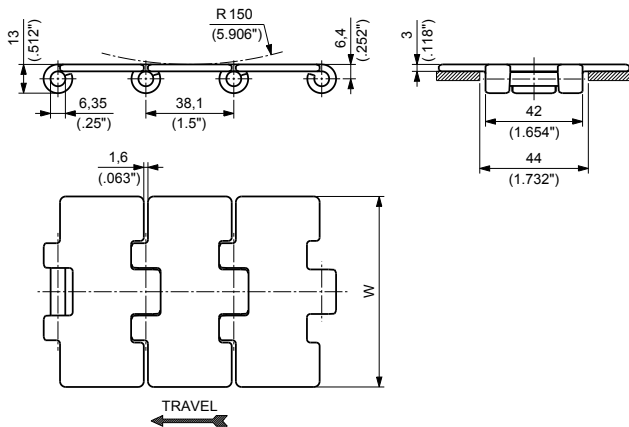
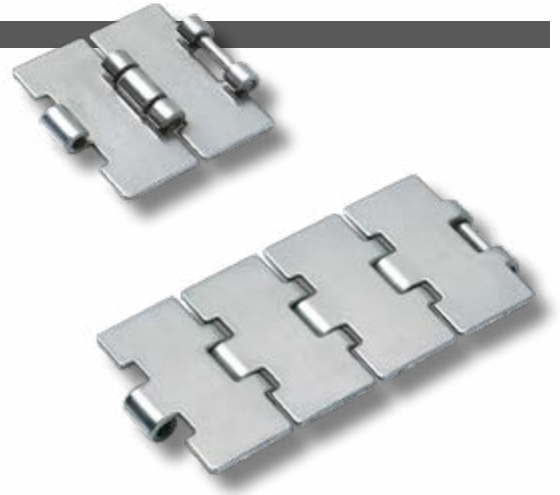

Materials  
see page 12



Sprockets  
see pages 120-127



Applications  
see page 20

MATERIALS		ITEM DESCRIPTION	PART NUMBER	WIDTH W		SURFACE FINISH Ra	POLISHED HINGES	YIELD LOAD AVERAGE		WEIGHT	
Plate	Pin			mm	inch			N	lbs	kg/m	lbs/ft
CARBON STEEL <b>S</b>	CASE HARDENED STEEL	S 915 K 3 ¼	S915KD/000	82,6	3.25	-	NO	12300	2,765	2,58	1.73
		S 915 K 4	S915KF/000	101,6	4.00	-	NO	12300	2,765	3,01	2.02
		S 915 K 4 ½	S915KG/000	114,3	4.50	-	NO	12300	2,765	3,30	2.22
		S 915 K 6	S915KH/000	152,4	6.00	-	NO	12300	2,765	4,15	2.79
		S 915 K 7 ½	S915KL/000	190,5	7.50	-	NO	12300	2,765	5,02	3.38
FERRITIC STAINLESS STEEL <b>SS-4</b>	AUSTENITIC STAINLESS STEEL	SS 915-4 K 3 ¼	SS915-4KD/000	82,6	3.25	0,3	NO	5800	1,304	2,52	1.69
		SS 915-4 K 83,8	SS915-4KRA/000	83,8	3.30	0,3	NO	5800	1,304	2,55	1.71
		SS 915-4 K 4 ½	SS915-4KG/000	114,3	4.50	0,3	NO	5800	1,304	3,21	2.16
		SS 915-4 K 7 ½	SS915-4KL/000	190,5	7.50	0,3	NO	5800	1,304	4,96	3.33
AUSTENITIC STAINLESS STEEL <b>SS</b>	AUSTENITIC STAINLESS STEEL	SS 915 K 3 ¼	SS915KD/000	82,6	3.25	0,3	NO	5600	1,259	2,57	1.72
		SS 915 K 4	SS915KF/000	101,6	4.00	0,3	NO	5600	1,259	2,99	2.01
		SS 915 K 4 ½	SS915KG/000	114,3	4.50	0,3	NO	5600	1,259	3,28	2.20
		SS 915 K 6	SS915KH/000	152,4	6.00	0,3	NO	5600	1,259	4,13	2.78
		SS 915 K 7 ½	SS915KL/000	190,5	7.50	0,3	NO	5600	1,259	4,99	3.35



Standard packaging:  
Rolls of 3,048 m (10 feet)

## DOUBLE HINGE

PITCH 1 1/2" (38,1 mm)

THICKNESS 3 mm (0.118")

HINGE 80 mm (3.150")

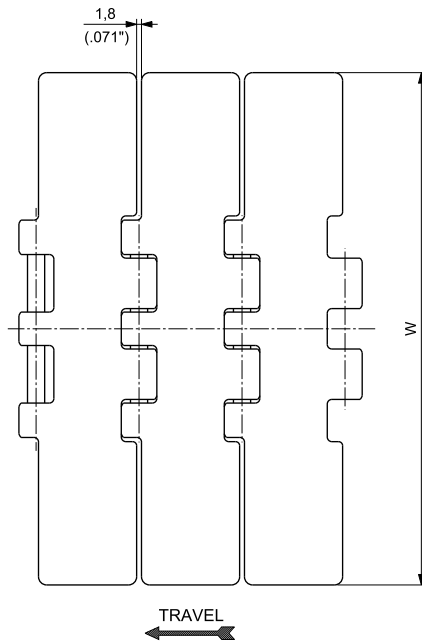
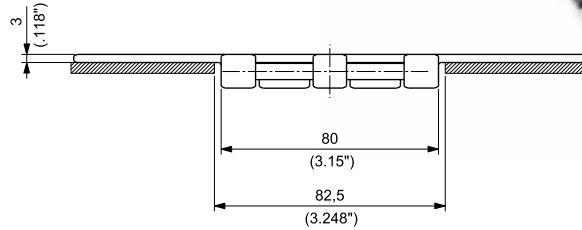
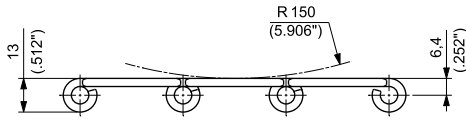
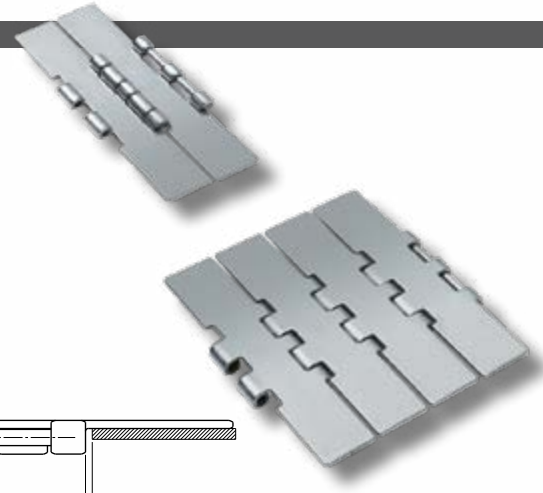

Materials  
see page 12



Sprockets  
see pages 128+131



Applications  
see page 20

MATERIALS		ITEM DESCRIPTION	PART NUMBER	WIDTH W		SURFACE FINISH Ra	POLISHED HINGES	YIELD LOAD AVERAGE		WEIGHT	
Plate	Pin			mm	inch			N	lbs	kg/m	lbs/ft
CARBON STEEL <b>S</b>	CASE HARDENED STEEL	S 2815 K 7 1/2	S2815KL/000	190,5	7.50	0,3	NO	18000	4,046	5,56	3.73
FERRITIC STAINLESS STEEL <b>SS-4</b>	AUSTENITIC STAINLESS STEEL	SS 2815-4 K 7 1/2	SS28154KL/000	190,5	7.50	0,3	NO	10300	2,315	5,58	3.75
AUSTENITIC STAINLESS STEEL <b>SS</b>	AUSTENITIC STAINLESS STEEL	SS 2815 K 7 1/2	SS2815KL/000	190,5	7.50	0,3	NO	10600	2,383	5,61	3.77
<b>PRIMA</b> <b>P</b>	AUSTENITIC STAINLESS STEEL	P 2815 K 7 1/2	P2815KL/000	190,5	7.50	0,3	NO	15000	3,372	5,60	3.75



Standard packaging:  
Rolls of 3,048 m (10 feet)

**HEAVY DUTY SINGLE HINGE**  
**INCREASED PIN HARDNESS**  
**PITCH 1 ½" (38,1 mm)**  
**THICKNESS 3 mm (0.118")**  
**HINGE 57 mm (2.244")**

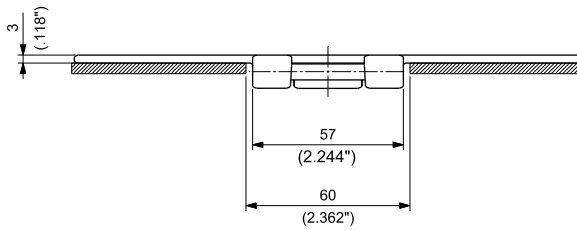
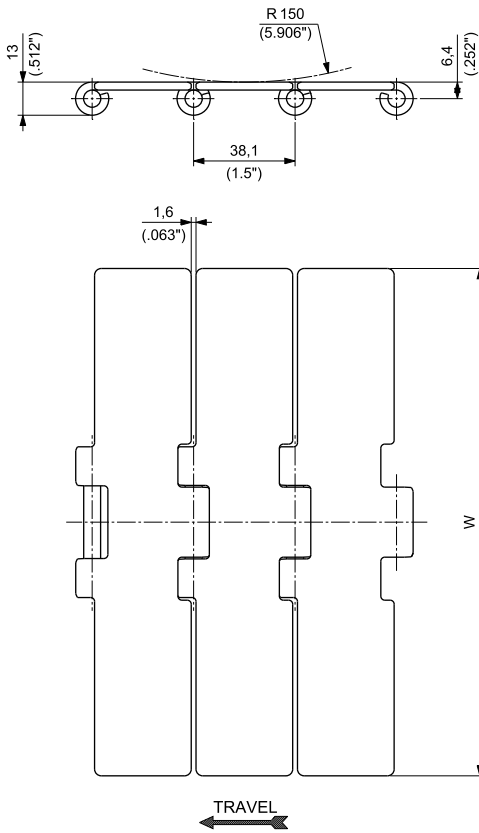

Materials  
see page 12



Sprockets  
see pages 132-133



Applications  
see page 20

MATERIALS		ITEM DESCRIPTION	PART NUMBER	WIDTH W		SURFACE FINISH Ra	POLISHED HINGES	YIELD LOAD AVERAGE		WEIGHT	
Plate	Pin			mm	inch			N	lbs	kg/m	lbs/ft
PRIMA P	HARDENED MARTENSITIC STAINLESS STEEL	PHD 9157 K 7 ½	PHD9157KL/000	190,5	7.50	0,3	NO	10500	2,360	5,28	3.55



Standard packaging:  
Rolls of 3,048 m (10 feet)

## MINI HINGE

PITCH 1 1/2" (38,1 mm)

THICKNESS 3 mm (0.118")

HINGE 22 mm (0.866")

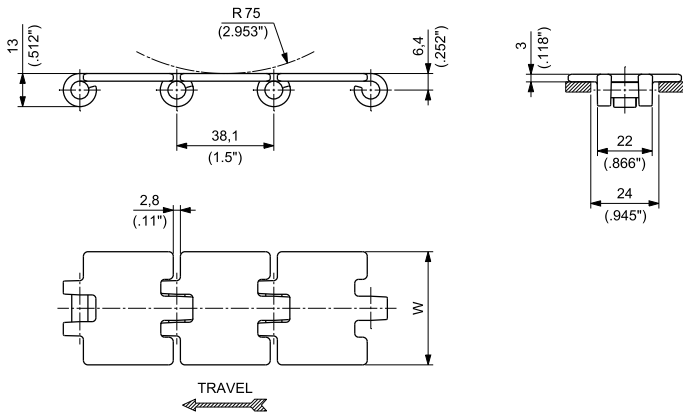

Materials  
see page 12



Sprockets  
see pages 134÷136



Applications  
see page 20

MATERIALS		ITEM DESCRIPTION	PART NUMBER	WIDTH W		SURFACE FINISH	POLISHED HINGES	YIELD LOAD AVERAGE		WEIGHT	
Plate	Pin			mm	inch	Ra		N	lbs	kg/m	lbs/ft
PRIMA	AUSTENITIC STAINLESS STEEL	P 803 K 1 1/4	P803KPA/000	31,8	1.25	0,3	NO	4100	922	1,06	0.71
P		P 803 K 1 3/4	P803KFA/000	44,5	1.75	0,3	NO	4100	922	1,33	0.90



Standard packaging:  
Rolls of 3,048 m (10 feet)



**BEVEL**  
**PITCH 1 ½" (38,1 mm)**  
**THICKNESS 3 mm (0.118")**  
**HINGE 43 mm (1.693")**

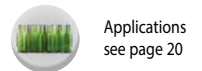
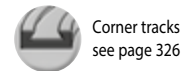
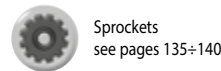
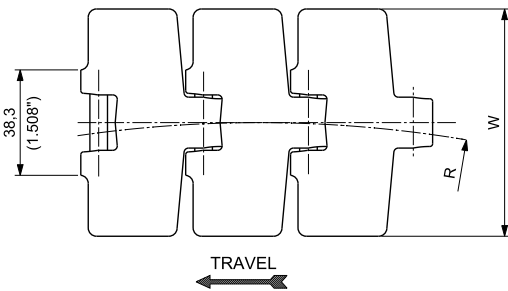
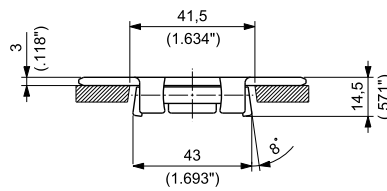
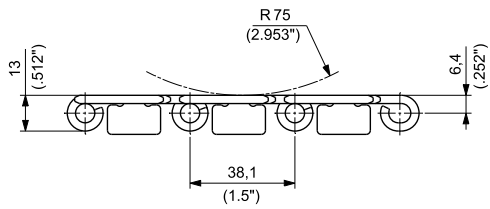

MATERIALS		ITEM DESCRIPTION	PART NUMBER	WIDTH W		SURFACE FINISH Ra	POLISHED HINGES	SIDEFLEXING RADIUS		YIELD LOAD AVERAGE		WEIGHT	
Plate	Pin			mm	inch			mm	R inch	N	lbs	kg/m	lbs/ft
CARBON STEEL S	CASE HARDENED STEEL	S 881 K 3 ¼	S881KD/000	82,6	3.25	-	NO	457,2	18	11600	2,608	2,74	1.84
		S 881 K 4 ½	S881KG/000	114,3	4.50	-	NO	609,6	24	11600	2,608	3,37	2.27
		S 881 K 7 ½	S881KL/000	190,5	7.50	-	NO	609,6	24	11600	2,608	3,78	2.54
AUSTENITIC STAINLESS STEEL SS	AUSTENITIC STAINLESS STEEL	SS 881 K 3 ¼	SS881KD/000	82,6	3.25	0,3	NO	457,2	18	5600	1,259	2,76	1.85
		SS 881 K 4 ½	SS881KG/000	114,3	4.50	0,3	NO	609,6	24	5600	1,259	3,40	2.29
		SS 881 K 7 ½	SS881KL/000	190,5	7.50	0,3	NO	609,6	24	5600	1,259	4,82	3.24

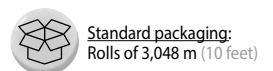

**BEVEL**  
**REDUCED PLATE GAP**  
**PITCH 1 ½" (38,1 mm)**  
**THICKNESS 3 mm (0.118")**  
**HINGE 43 mm (1.693")**

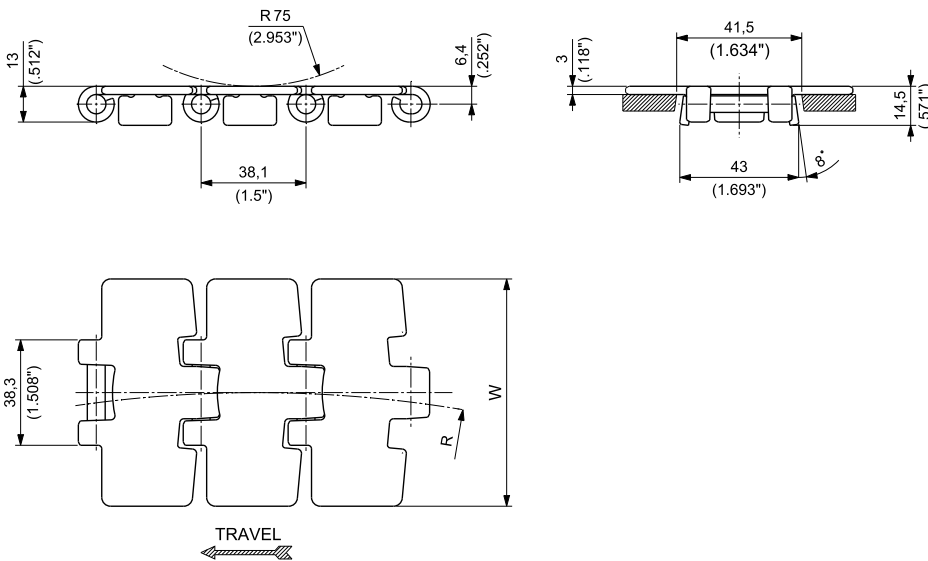

FliteTop



Materials  
see page 12



Sprockets  
see pages 134÷139



Corner tracks  
see page 326



Applications  
see page 20

MATERIALS		ITEM DESCRIPTION	PART NUMBER	WIDTH W		SURFACE FINISH Ra	POLISHED HINGES	SIDEFLEXING RADIUS R		YIELD LOAD AVERAGE		WEIGHT	
Plate	Pin			mm	inch			mm	inch	N	lbs	kg/m	lbs/ft
<b>PRIMA</b> <b>P</b>	AUSTENITIC STAINLESS STEEL	P 981 K 3 ¼	P981KD/000	82,6	3.25	0,3	NO	457,2	18	8000	1,798	2,74	1.84
		P 981 K 83,8	P981KRA/000	83,8	3.30	0,3	NO	457,2	18	8000	1,798	2,77	1.86
		P 981 K 4 ½	P981KG/000	114,3	4.50	0,3	NO	609,6	24	8000	1,798	3,38	2.27
		P 981 K 7 ½	P981KL/000	190,5	7.50	0,3	NO	609,6	24	8000	1,798	4,82	3.24



Standard packaging:  
Rolls of 3,048 m (10 feet)

## TAB

**PITCH 1 ½" (38,1 mm)**

**THICKNESS 3 mm (0.118")**

**HINGE 43 mm (1.693")**

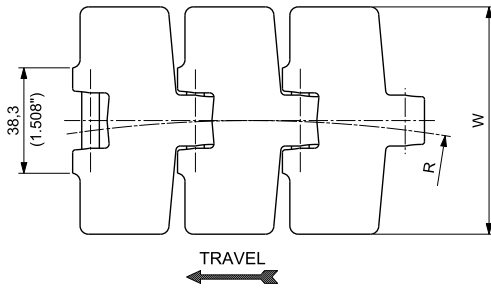
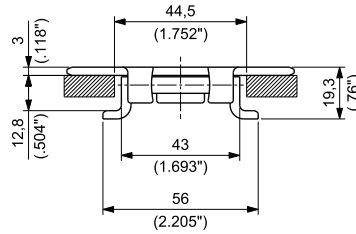
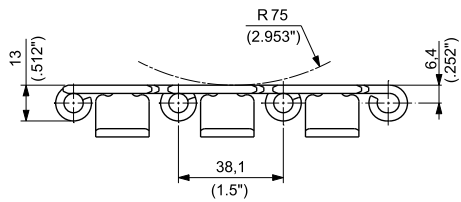

Materials  
see page 12



Sprockets  
see pages 135-140



Corner tracks  
see page 320



Applications  
see page 20

MATERIALS		ITEM DESCRIPTION	PART NUMBER	WIDTH W		SURFACE FINISH Ra	POLISHED HINGES	SIDEFLEXING RADIUS		YIELD LOAD AVERAGE		WEIGHT	
Plate	Pin			mm	inch			mm	R inch	N	lbs	kg/m	lbs/ft
CARBON STEEL S	CASE HARDENED STEEL	S 881T K 3 ¼	S881TKD/000	82,6	3.25	-	NO	457,2	18	11600	2,608	2,96	1.99
		S 881T K 4 ½	S881TKG/000	114,3	4.50	-	NO	609,6	24	11600	2,608	3,60	2.42
		S 881T K 7 ½	S881TKL/000	190,5	7.50	-	NO	609,6	24	11600	2,608	5,01	3.36
AUSTENITIC STAINLESS STEEL SS	AUSTENITIC STAINLESS STEEL	SS 881T K 3 ¼	SS881TKD/000	82,6	3.25	0,3	NO	457,2	18	5600	1,259	2,99	2.01
		SS 881T K 4 ½	SS881TKG/000	114,3	4.50	0,3	NO	609,6	24	5600	1,259	3,63	2.44
		SS 881T K 7 ½	SS881TKL/000	190,5	7.50	0,3	NO	609,6	24	5600	1,259	5,05	3.39



Standard packaging:  
Rolls of 3,048 m (10 feet)

**TAB**  
**REDUCED PLATE GAP**  
**PITCH 1 1/2" (38,1 mm)**  
**THICKNESS 3 mm (0.118")**  
**HINGE 43 mm (1.693")**

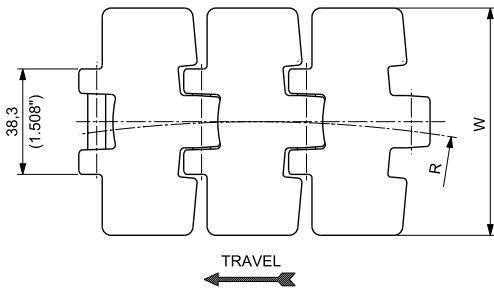
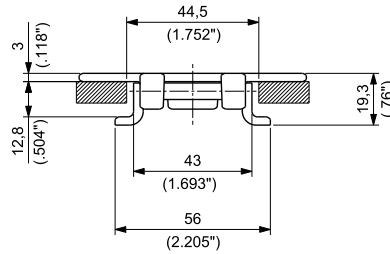
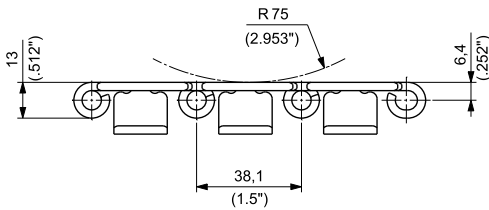

**FliteTop**



Materials  
see page 12



Sprockets  
see pages 135+140



Corner tracks  
see page 320



Applications  
see page 20

MATERIALS	ITEM DESCRIPTION	PART NUMBER	WIDTH W		SURFACE FINISH Ra	POLISHED HINGES	SIDEFLEXING RADIUS		YIELD LOAD AVERAGE		WEIGHT	
			mm	inch			mm	R inch	N	lbs	kg/m	lbs/ft
Plate	Pin											
<b>PRIMA</b> <b>P</b> AUSTENITIC STAINLESS STEEL	P 981T K 3 1/4	P981TKD/000	82,6	3.25	0,3	NO	457,2	18	8000	1,798	2,97	2.00
	P 981T K 83,8	P981TKRA/000	83,8	3.30	0,3	NO	457,2	18	8000	1,798	2,99	2.01
	P 981T K 4 1/2	P981TKG/000	114,3	4.50	0,3	NO	609,6	24	8000	1,798	3,61	2.43
	P 981T K 7 1/2	P981TKL/000	190,5	7.50	0,3	NO	609,6	24	8000	1,798	5,05	3.40



Standard packaging:  
Rolls of 3,048 m (10 feet)

**MAGNETIC**  
**REDUCED PLATE GAP**  
**INCREASED PIN HARDNESS (PHD 981M SERIES)**  
**SPECIAL XPHD CHAINS FOR PRESSURELESS COMBINERS** **NEW**  
**PITCH 1 1/2" (38,1 mm)**  
**THICKNESS 3 mm (0.118")**  
**HINGE 42 mm (1.654")**

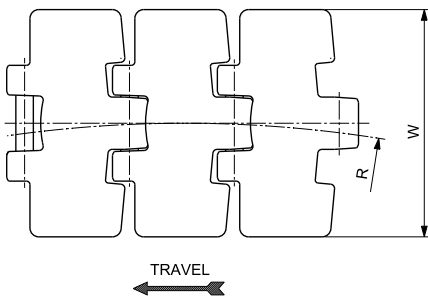
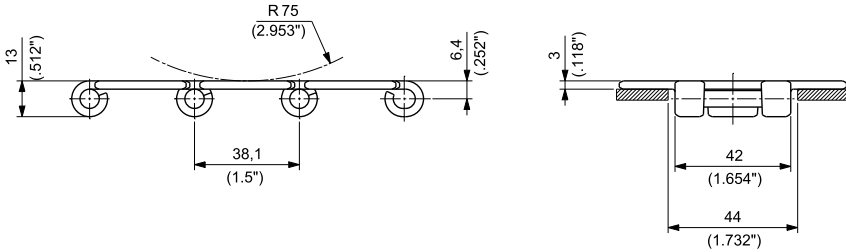

Materials  
see page 12



Sprockets  
see pages 120-127



Corner tracks  
see page 280



Applications  
see page 20

## 981M

MATERIALS		ITEM DESCRIPTION	PART NUMBER	WIDTH W		SURFACE FINISH Ra	POLISHED HINGES	SIDEFLEXING RADIUS R		YIELD LOAD AVERAGE		WEIGHT	
Plate	Pin			mm	inch			mm	inch	N	lbs	kg/m	lbs/ft
FERRITIC STAINLESS STEEL SS-4	AUSTENITIC STAINLESS STEEL	SS 981M-4 K 3 1/4	SS981M4KD/000	82,6	3.25	0,3	YES	500	19.69	5400	1,214	2,43	1.63
		SS 981M-4 K 83,8	SS981M4KRA/000	83,8	3.30	0,3	YES	500	19.69	5400	1,214	2,45	1.63
		SS 981M-4 K 4 1/2	SS981M4KG/000	114,3	4.50	0,3	YES	500	19.69	5400	1,214	3,05	2.05
		SS 981M-4 K 7 1/2	SS981M4KL/000	190,5	7.50	0,3	YES	500	19.69	5400	1,214	4,43	2.98
PRIMA P	AUSTENITIC STAINLESS STEEL	P 981M K 3 1/4	P981MKD/000	82,6	3.25	0,3	YES	500	19.69	8500	1,911	2,44	1.64
		P 981M K 83,8	P981MKRA/000	83,8	3.30	0,3	YES	500	19.69	8500	1,911	2,47	1.66
		P 981M K 4 1/2	P981MKG/000	114,3	4.50	0,3	YES	500	19.69	8500	1,911	3,07	2.06
		P 981M K 7 1/2	P981MKL/000	190,5	7.50	0,3	YES	500	19.69	8500	1,911	4,47	3.01

## PHD 981M

MATERIALS		ITEM DESCRIPTION	PART NUMBER	WIDTH W		SURFACE FINISH Ra	POLISHED HINGES	SIDEFLEXING RADIUS R		YIELD LOAD AVERAGE		WEIGHT	
Plate	Pin			mm	inch			mm	inch	N	lbs	kg/m	lbs/ft
PRIMA P	HARDENED MARTENSITIC STAINLESS STEEL	<b>NEW</b> XPHD 981M K 3 1/4	XPHD981MKD/000	82,6	3.25	0,2	YES	500	19.69	8500	1,911	2,44	1.64
		<b>NEW</b> XPHD 981M K 83,8	XPHD981MKRA/000	83,8	3.30	0,2	YES	500	19.69	8500	1,911	2,47	1.66
		PHD 981M K 4 1/2	PHD981MKG/000	114,3	4.50	0,3	YES	500	19.69	8500	1,911	3,07	2.06
		PHD 981M K 7 1/2	PHD981MKL/000	190,5	7.50	0,3	YES	500	19.69	8500	1,911	4,47	3.01



Standard packaging:  
Rolls of 3,048 m (10 feet)



**MAGNETIC**  
**HEAVY DUTY SINGLE HINGE**  
**INCREASED PIN HARDNESS**  
**PITCH 1 ½" (38,1 mm)**  
**THICKNESS 3 mm (0.118")**  
**HINGE 57 mm (2.244")**

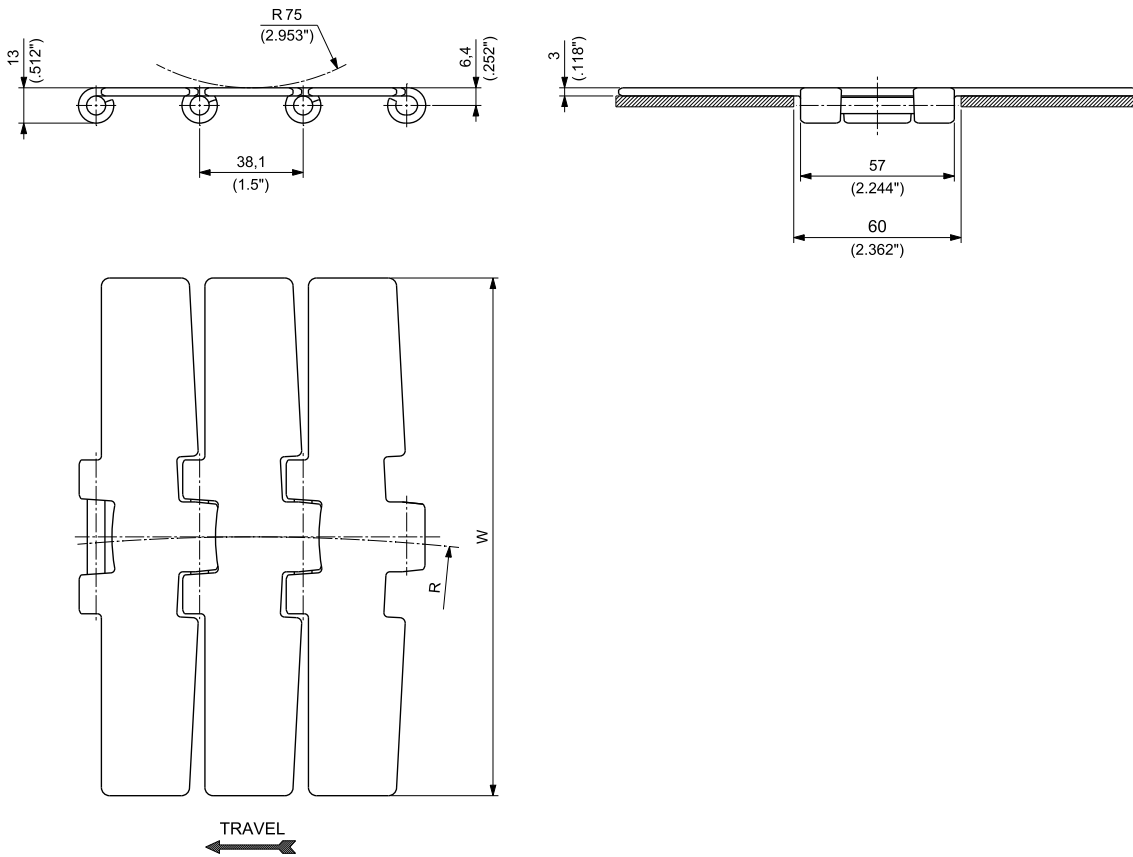

**FliteTop**



Materials  
see page 12



Sprockets  
see pages 132-133



Corner tracks  
see page 280



Applications  
see page 20

MATERIALS		ITEM DESCRIPTION	PART NUMBER	WIDTH W		SURFACE FINISH Ra	POLISHED HINGES	SIDEFLEXING RADIUS		YIELD LOAD AVERAGE		WEIGHT	
Plate	Pin			mm	inch			mm	R inch	N	lbs	kg/m	lbs/ft
<b>PRIMA</b>	HARDENED MARTENSITIC STAINLESS STEEL	PHD 9857M K 7 ½	PHD9857MKL/000	190,5	7.50	0,3	YES	750	29.53	10500	2,360	4,97	3.34
<b>P</b>													



Standard packaging:  
Rolls of 3,048 m (10 feet)

**TAB**  
**REDUCED SIDEFLEXING RADIUS**  
**PITCH 1 1/2" (38,1 mm)**  
**THICKNESS 3 mm (0.118")**  
**HINGE 43 mm (1.693")**

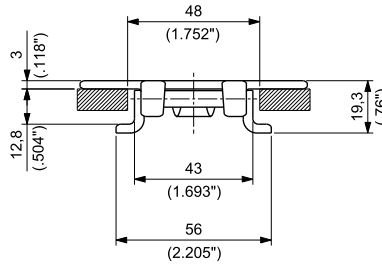
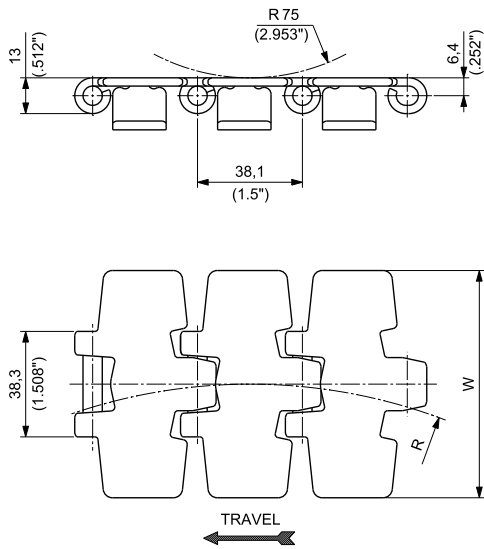

Materials  
see page 12



Sprockets  
see pages 135÷140



Corner tracks  
see page 320



Applications  
see page 20

MATERIALS		ITEM DESCRIPTION	PART NUMBER	WIDTH W		SURFACE FINISH Ra	POLISHED HINGES	SIDEFLEXING RADIUS		YIELD LOAD AVERAGE		WEIGHT	
Plate	Pin			mm	inch			mm	R inch	N	lbs	kg/m	lbs/ft
AUSTENITIC STAINLESS STEEL	AUSTENITIC STAINLESS STEEL	SS 982T K 3 1/4	SS982TKD/000	82,6	3.25	0,3	NO	200	7.87	5000	1,125	3,00	2.02
SS													



Standard packaging:  
Rolls of 3,048 m (10 feet)



PERFORMANCE IN MOTION

***FliteTop***<sup>®</sup>

Rubberized Surface  
Steel Chains

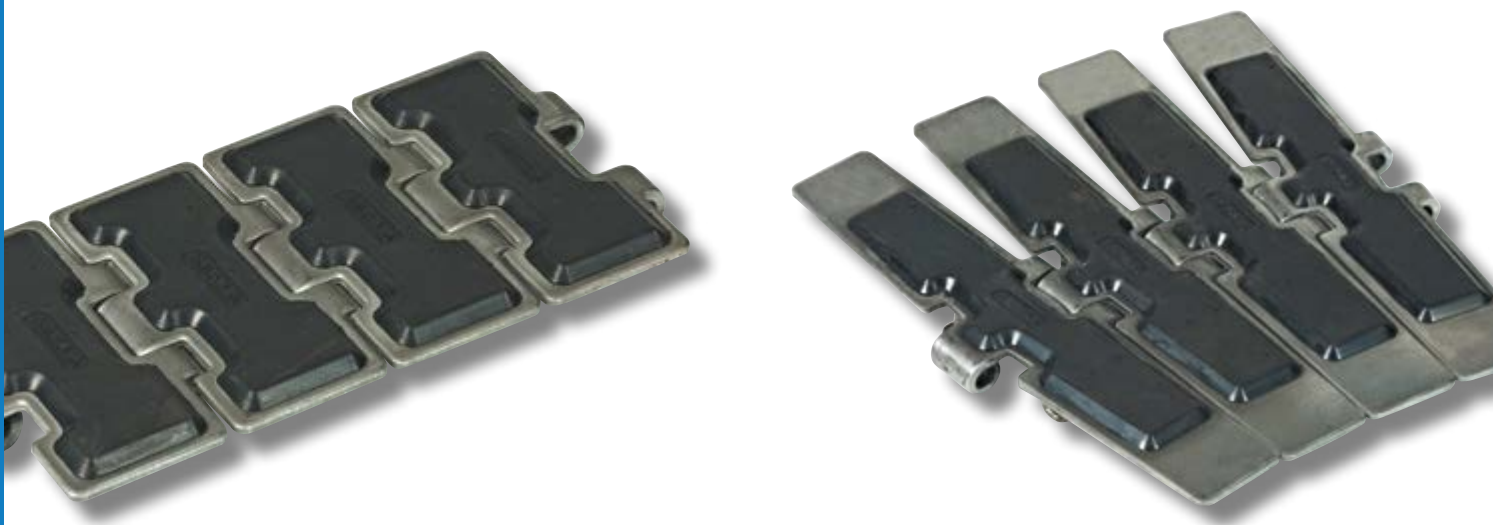

## SINGLE HINGE

- PLATE GAP 1,6 mm
- INCREASED PIN HARDNESS
- PITCH 1 ½" (38,1 mm)
- THICKNESS 3 mm (0.118")
- HINGE 42 mm (1.654")

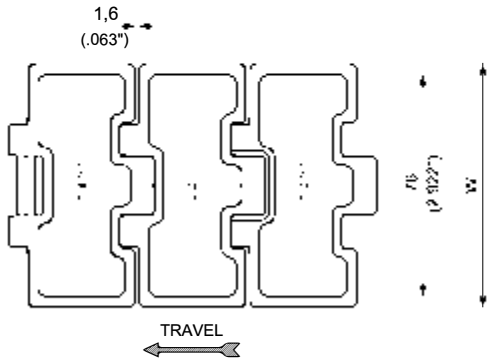
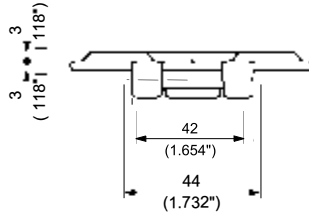
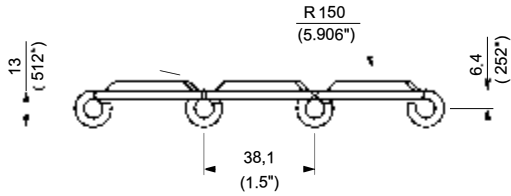

K 3/4 - K 4 1/2

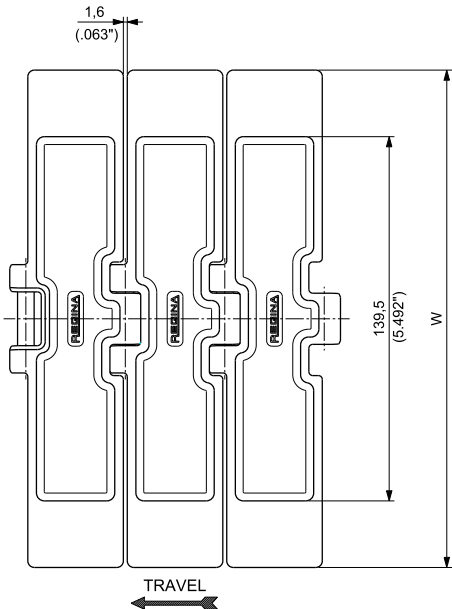
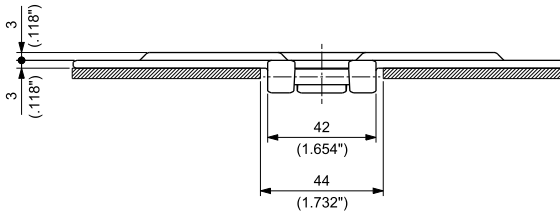
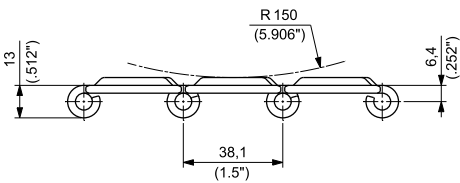

K 7 1/2



Materials see page 12



Sprockets see pages 120÷127



Applications see page 20

MATERIALS			ITEM DESCRIPTION	PART NUMBER	WIDTH W		POLISHED HINGES	YIELD LOAD AVERAGE		WEIGHT	
Plate	Pin	Rubber			mm	inch		N	lbs	kg/m	lbs/ft
PRIMA	HARDENED MARTENSITIC STAINLESS STEEL	NBR Hardness: 70 ShA	PHDG 915 K 3/4	PHDG915KD/000	82,6	3.25	YES	8500	1,911	2,57	1.73
P			PHDG 915 K 4 1/2	PHDG915KG/000	114,3	4.50	NO	8500	1,911	3,28	2.20
			PHDG 915 K 7 1/2	PHDG915KL/000	190,5	7.50	NO	8500	1,911	4,99	3.35



Standard packaging:  
Rolls of 3,048 m (10 feet)

**DOUBLE HINGE**  
**INCREASED PIN HARDNESS**  
**PITCH 1 ½" (38,1 mm)**  
**THICKNESS 3 mm (0.118")**  
**HINGE 80 mm (3.150")**

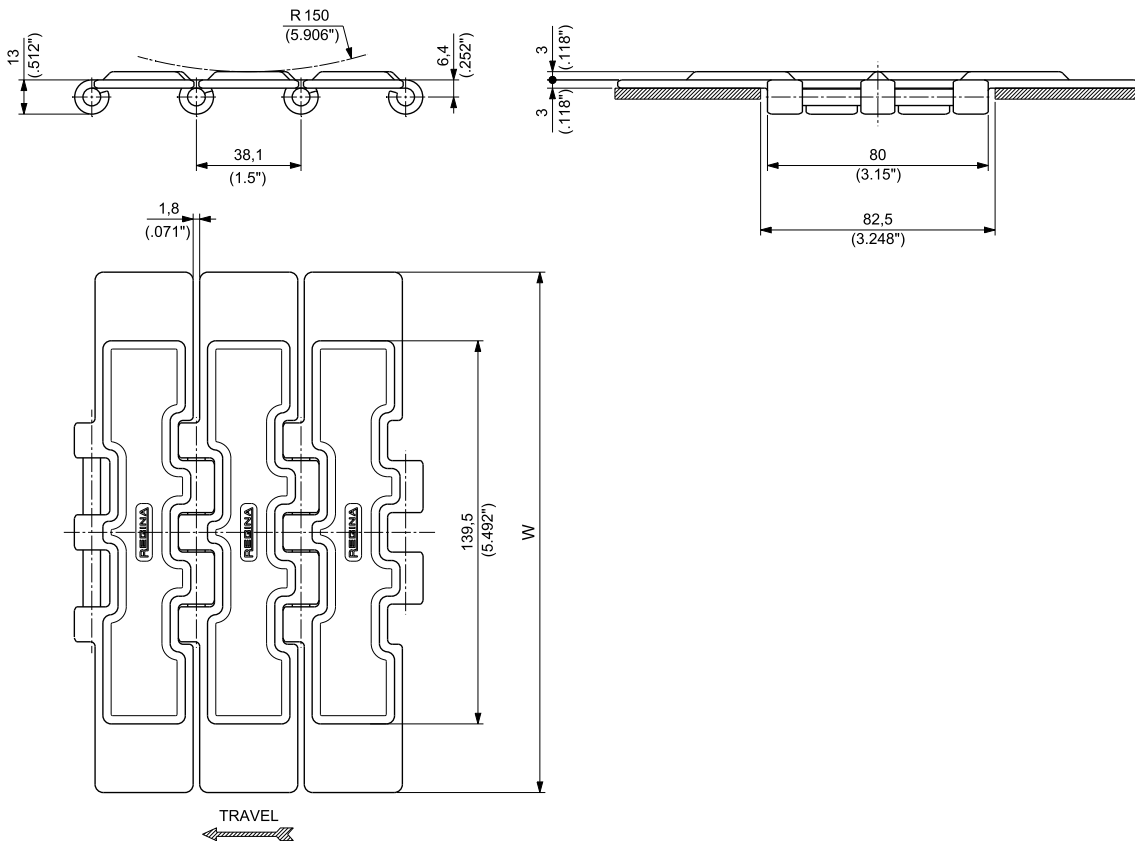
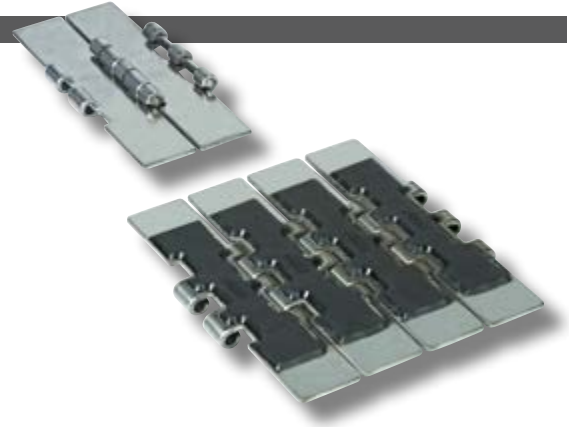

**FliteTop**



Materials  
see page 12



Sprockets  
see pages 128-131



Applications  
see page 20

MATERIALS			ITEM DESCRIPTION	PART NUMBER	WIDTH W		POLISHED HINGES	YIELD LOAD AVERAGE		WEIGHT	
Plate	Pin	Rubber			mm	inch		N	lbs	kg/m	lbs/ft
PRIMA P	HARDENED MARTENSITIC STAINLESS STEEL	<b>NBR</b> Hardness: 70 ShA	PHDG 2815 K 7 ½	PHDG2815KL/000	190,5	7.50	NO	15000	3,372	5,60	3.75



Standard packaging:  
Rolls of 3,048 m (10 feet)



**HEAVY DUTY SINGLE HINGE**  
**INCREASED PIN HARDNESS**  
**PITCH 1 ½" (38,1 mm)**  
**THICKNESS 3 mm (0.118")**  
**HINGE 57 mm (2.244")**

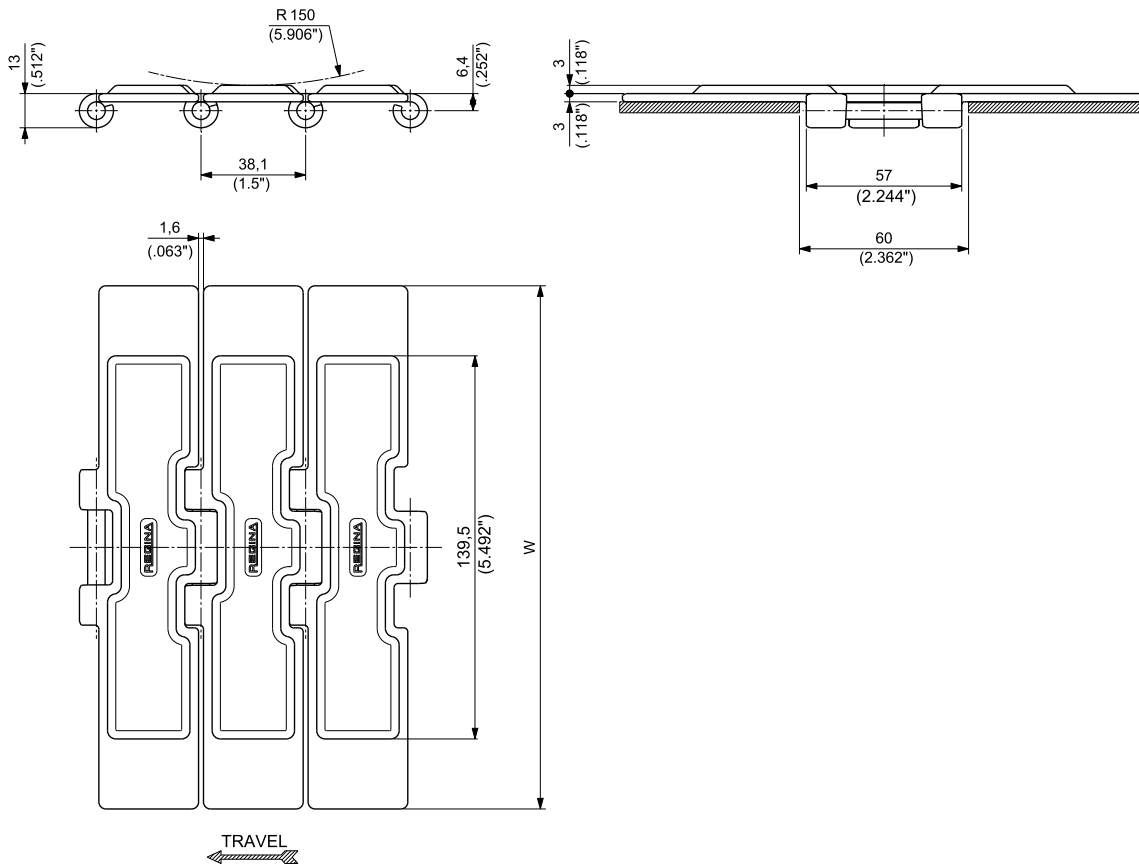
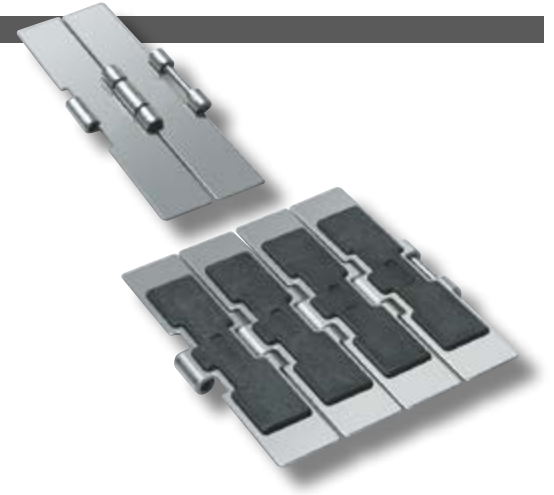

Materials  
see page 12



Sprockets  
see pages 132÷133



Applications  
see page 20

MATERIALS			ITEM DESCRIPTION	PART NUMBER	WIDTH W		POLISHED HINGES	YIELD LOAD AVERAGE		WEIGHT	
Plate	Pin	Rubber			mm	inch		N	lbs	kg/m	lbs/ft

**PRIMA**  
**P**

HARDENED MARTENSITIC  
STAINLESS STEEL

**NBR**  
Hardness: 70 ShA

PHDG 9157 K 7 ½

PHDG9157KL/000

190,5

7.50

NO

10500

2,360

5,28

3.55



Standard packaging:  
Rolls of 3,048 m (10 feet)

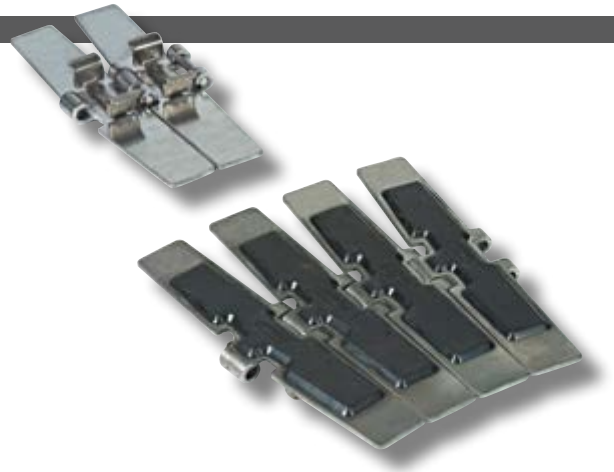

**TAB**  
**REDUCED PLATE GAP**  
**INCREASED PIN HARDNESS**  
**PITCH 1 ½" (38,1 mm)**  
**THICKNESS 3 mm (0.118")**  
**HINGE 43 mm (1.693")**

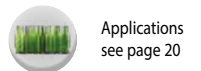
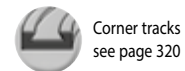
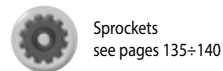
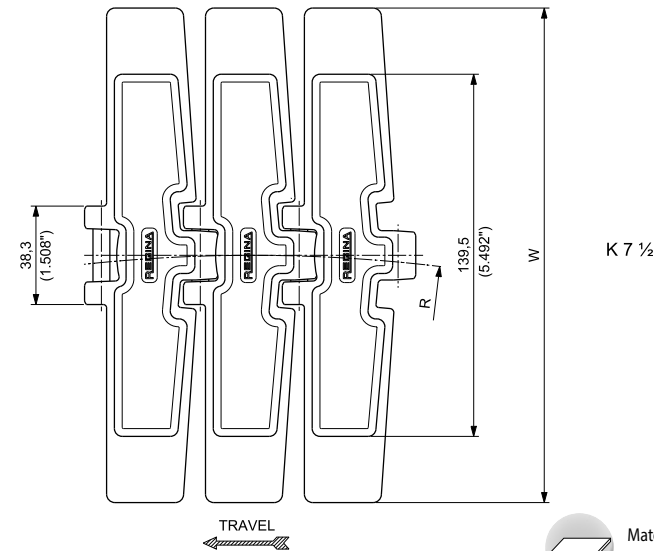
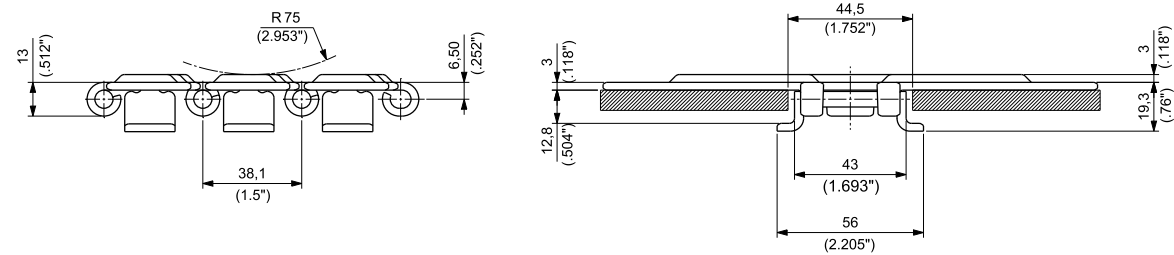
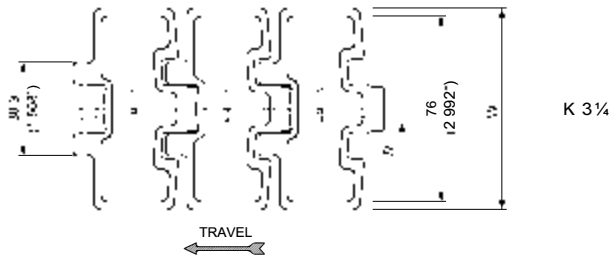
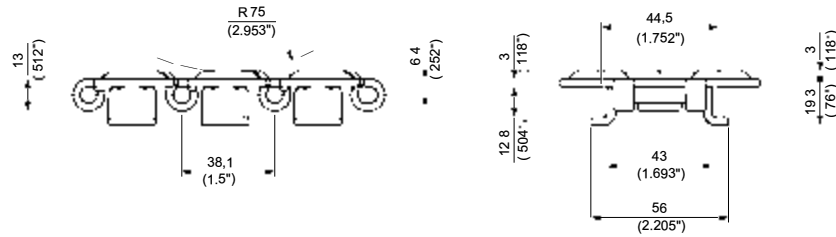

MATERIALS			ITEM DESCRIPTION	PART NUMBER	WIDTH W		POLISHED HINGES	SIDEFLEXING RADIUS R		YIELD LOAD AVERAGE		WEIGHT	
Plate	Pin	Rubber			mm	inch		mm	inch	N	lbs	kg/m	lbs/ft
<b>PRIMA</b>	HARDENED MARTENSITIC STAINLESS STEEL	<b>NBR</b>	PHDG 981T K 3 ¼	PHDG981TKD/0000	82,6	3.25	NO	457,2	18	8000	1,798	2,97	2.00
<b>P</b>		Hardness: 70 ShA	PHDG 981T K 7 ½	PHDG981TKL/000	190,5	7.50	NO	609,6	24	8000	1,798	5,06	3.40

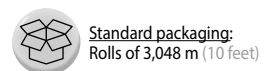

**MAGNETIC**  
**REDUCED PLATE GAP**  
**INCREASED PIN HARDNESS**  
**PITCH 1 ½" (38,1 mm)**  
**THICKNESS 3 mm (0.118")**  
**HINGE 42 mm (1.654")**

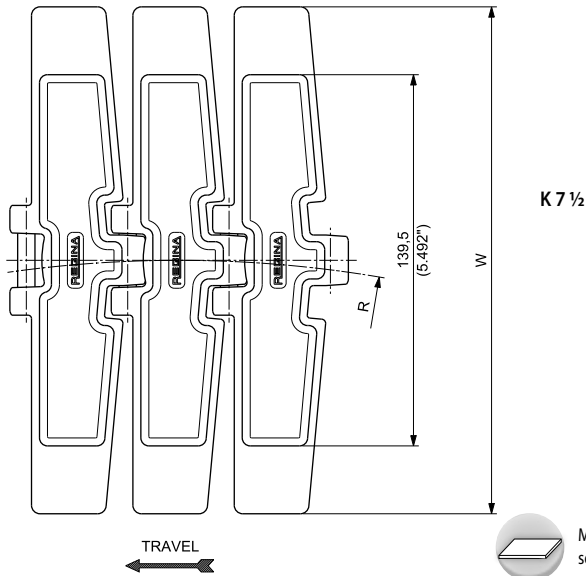
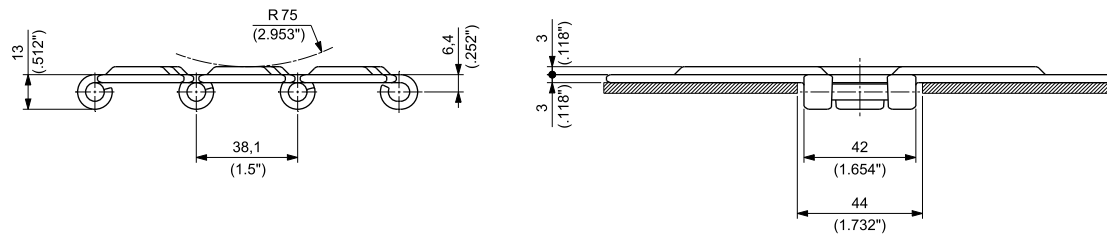
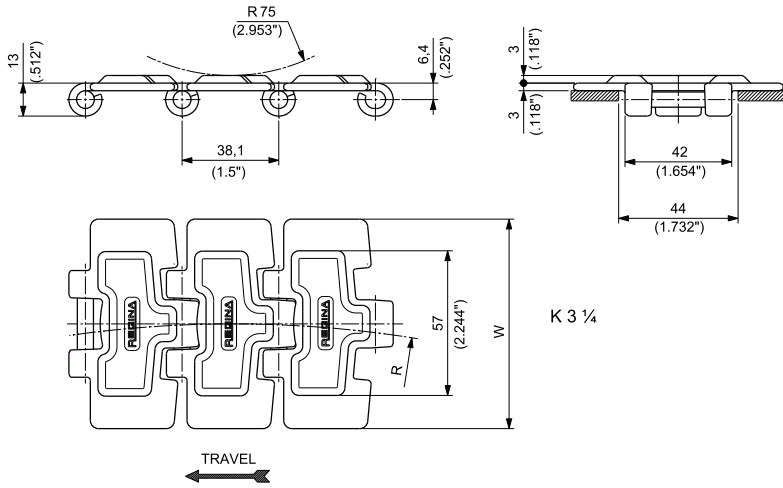
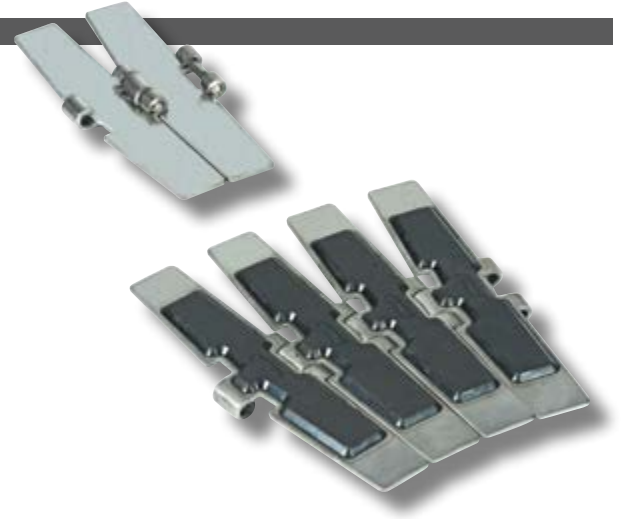

Materials  
see page 12



Sprockets  
see pages 120-127



Corner tracks  
see page 280



Applications  
see page 20

MATERIALS			ITEM DESCRIPTION	PART NUMBER	WIDTH W		POLISHED HINGES	SIDEFLEXING RADIUS		YIELD LOAD AVERAGE		WEIGHT	
Plate	Pin	Rubber			mm	inch		mm	inch	N	lbs	kg/m	lbs/ft
<b>PRIMA</b>	HARDENED MARTENSITIC STAINLESS STEEL	<b>NBR</b>	PHDG 981M K 3 ¼	PHDG981MKD/000	82,6	3.25	YES	500	19,69	8500	1,911	2,45	1.65
<b>P</b>		Hardness: 70 ShA	PHDG 981M K 7 ½	PHDG981MKL/000	190,5	7.50	YES	500	19,69	8500	1,911	4,47	3.01



Standard packaging:  
Rolls of 3,048 m (10 feet)

**MAGNETIC**  
**HEAVY DUTY SINGLE HINGE**  
**INCREASED PIN HARDNESS**  
**PITCH 1 ½" (38,1 mm)**  
**THICKNESS 3 mm (0.118")**  
**HINGE 57 mm (2.244")**

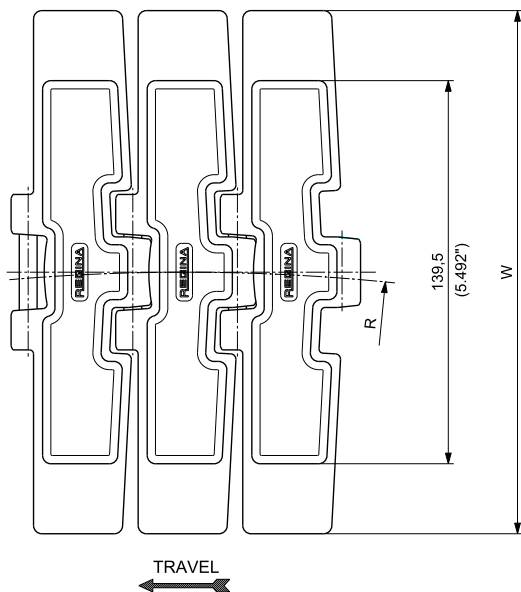
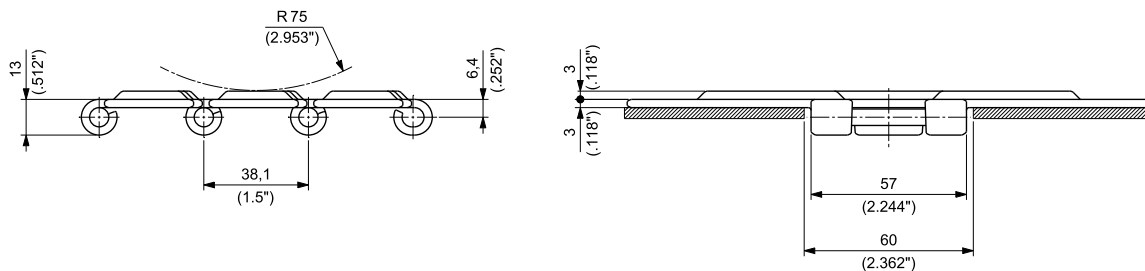
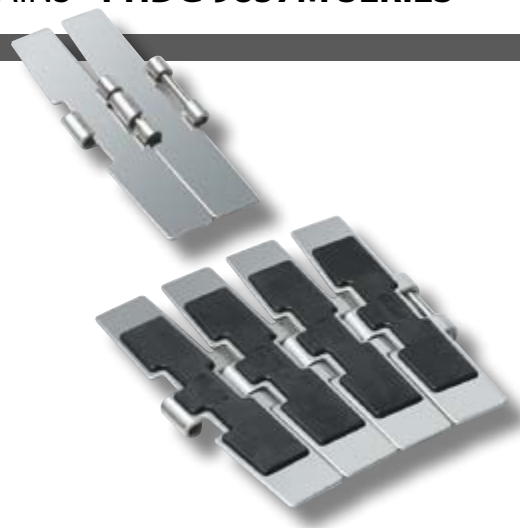

FliteTop



Materials  
see page 12



Sprockets  
see pages 132÷133



Corner tracks  
see pages 280



Applications  
see page 20

MATERIALS			ITEM DESCRIPTION	PART NUMBER	WIDTH W	POLISHED HINGES	SIDEFLEXING RADIUS	YIELD LOAD AVERAGE		WEIGHT			
Plate	Pin	Rubber			mm	inch	mm	R	inch	N	lbs	kg/m	lbs/ft
<b>PRIMA</b>	HARDENED MARTENSITIC STAINLESS STEEL	<b>NBR</b> Hardness: 70 Sha	PHDG 9857M K 7 ½	PHDG9857MKL/000	190,5	7.50	YES	750	29,53	10500	2,360	4,97	3.34



Standard packaging:  
Rolls of 3,048 m (10 feet)





PERFORMANCE IN MOTION

***FliteTop***<sup>®</sup>

Plastic Chains

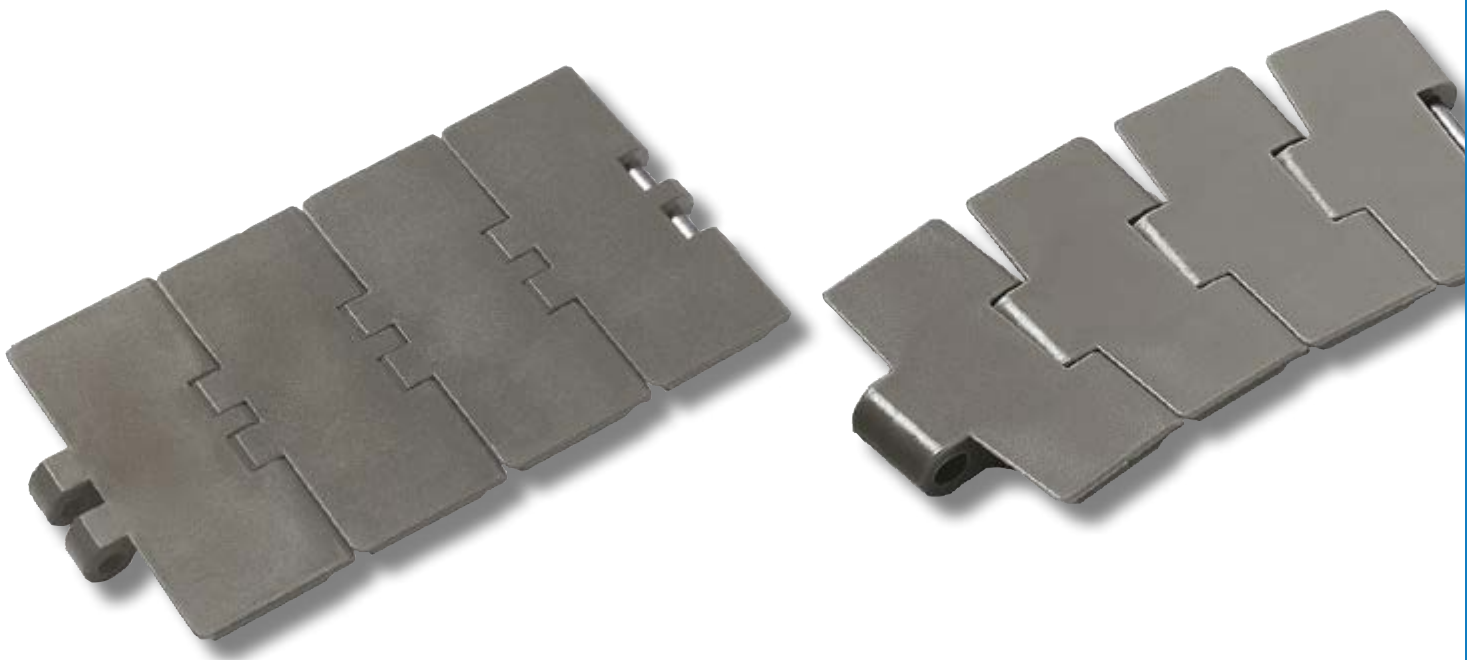

## INDUSTRIES AND APPLICATIONS

### PLASTIC CHAINS

Suitable for handling plastic and glass bottles, aluminum and steel cans. These products can be loose or packaged.

#### INDUSTRIES

Bottling and canning  
 Food filling  
 Container manufacturing  
 Pharmaceutical  
 Paper/cardboard  
 Glass manufacturing  
 Consumer goods

#### APPLICATIONS

Depalletizer  
 Pressureless Inliners and Combiners  
 Single lane and Mass conveyors  
 Accumulation tables  
 Infeed / outfeed packaging machines  
 Packaged product convey

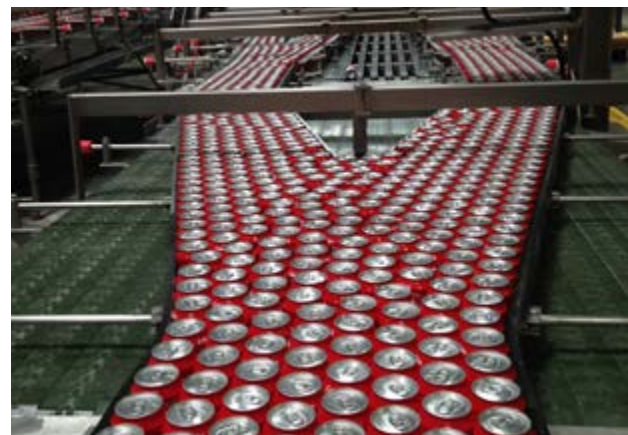

## FEATURES

- Highest standard of flatness thanks to the outperforming moulding process.
- Complete range of materials available, specifically defined for each type of application.
- **DK<sup>2</sup>** material available, developed with DuPont® with Kevlar® fiber inside. Lower Friction and maximum wear resistance are the superior properties of this material, allowing greater chain life, cost saving and environmental protection.
- **e-FAST** material available, developed with DuPont®. Capable of exceeding such standards, thanks to its unique characteristic of delivering a much lower and constant coefficient of friction over time in dry or almost dry running conditions vs. other plastic chains.
- Equipped with austenitic stainless steel pins (except for the magnetic chain) to achieve the maximum corrosion resistance.

## SINGLE HINGE

PITCH 1 1/2" (38,1 mm)

THICKNESS 4 mm (0.157")

HINGE 41,6 mm (1.638")

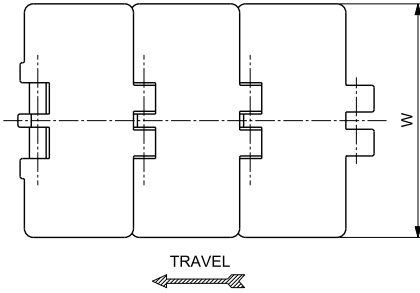
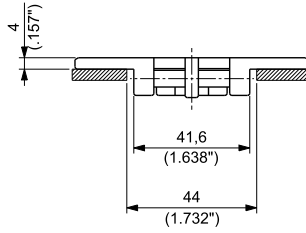
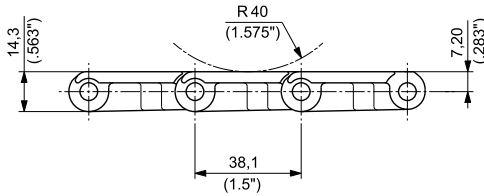
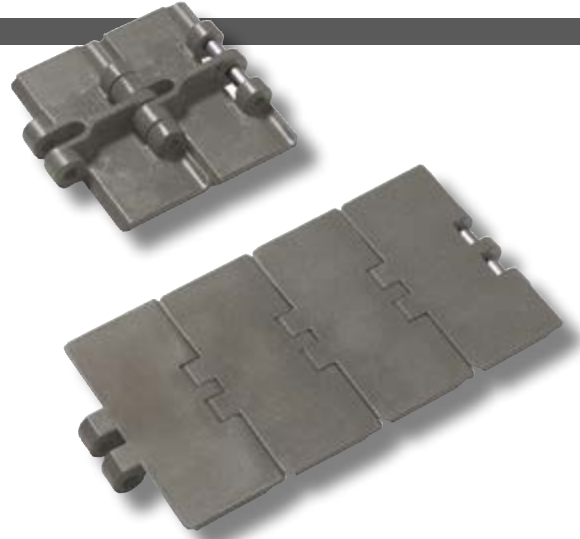

Materials  
see page 12



Sprockets  
see pages 141÷144



Applications  
see page 20

MATERIALS		ITEM DESCRIPTION	PART NUMBER	WIDTH W		PLATE THICKNESS		WORKING LOAD (25°C/77°F)		WEIGHT	
Plate	Pin			mm	inch	mm	inch	N	lbs	kg/m	lbs/ft
ULTRA PERFORMANCE HOMOPOLYMER DELRIN® <b>UP</b>	AUSTENITIC STAINLESS STEEL	UP 820 K 3 1/4	UP820KD/000	82,6	3.25	4,0	0.16	1600	360	0,87	0.58
		UP 820 K 83,8	UP820KRA/000	83,8	3.30	4,0	0.16	1600	360	0,88	0.59
		UP 820 K 4	UP820KF/000	101,6	4.00	4,0	0.16	1600	360	0,95	0.64
		UP 820 K 4 1/2	UP820KG/000	114,3	4.50	4,0	0.16	1600	360	1,03	0.69
		UP 820 K 6	UP820KH/000	152,4	6.00	4,0	0.16	1600	360	1,25	0.84
		UP 820 K 7 1/2	UP820KL/000	190,5	7.50	4,0	0.16	1600	360	1,35	0.90
SPECIAL DELRIN® REINFORCED WITH KEVLAR® <b>DK2™</b>	AUSTENITIC STAINLESS STEEL	D2K 820 K 3 1/4	D2K820KD/000	82,6	3.25	4,0	0.16	1600	360	0,85	0.57
		D2K 820 K 83,8	D2K820KRA/000	83,8	3.30	4,0	0.16	1600	360	0,86	0.58
		D2K 820 K 4 1/2	D2K820KG/000	114,3	4.50	4,0	0.16	1600	360	1,00	0.67
		D2K 820 K 7 1/2	D2K820KL/000	190,5	7.50	4,0	0.16	1600	360	1,36	0.90
NEW ECOLOGICAL FRICTION ABATING THERMOPLASTIC <b>e-FAST.</b>	AUSTENITIC STAINLESS STEEL	EF 820 K 3 1/4	EF820KD/000	82,6	3.25	4,0	0.16	1600	360	0,85	0.57
		EF 820 K 83,8	EF820KRA/000	83,8	3.30	4,0	0.16	1600	360	0,86	0.58
		EF 820 K 4 1/2	EF820KG/000	114,3	4.50	4,0	0.16	1600	360	1,00	0.67
ABRASION RESISTANT POLYAMIDE* <b>AR</b>	AUSTENITIC STAINLESS STEEL	AR 820 K 3 1/4	AR820KD/000	82,6	3.25	4,0	0.16	1600	360	0,85	0.57
		AR 820 K 4 1/2	AR820KG/000	114,3	4.50	4,0	0.16	1600	360	0,98	0.66

\*Actual width is larger than the nominal width.



Standard packaging:  
Rolls of 3,048 m (10 feet)

**REINFORCED SINGLE HINGE**  
**REDUCED PLATE GAP**  
**PITCH 1 ½" (38,1 mm)**  
**THICKNESS 4 mm (0.157")**  
**HINGE 42 mm (1.654")**

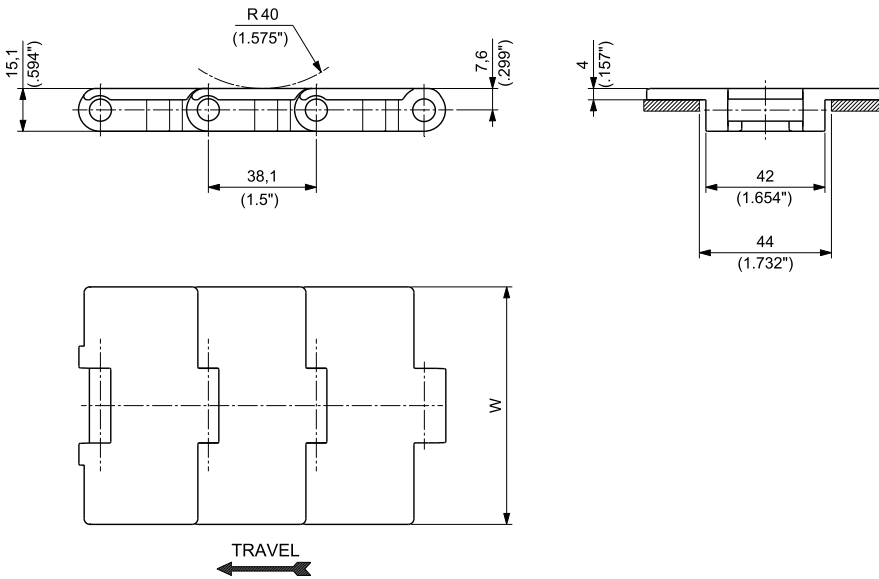

Materials  
see page 12



Sprockets  
see pages 147-148



Applications  
see page 20

MATERIALS		ITEM DESCRIPTION	PART NUMBER	WIDTH W		PLATE THICKNESS		WORKING LOAD (25°C/77°F)		WEIGHT	
Plate	Pin			mm	inch	mm	inch	N	lbs	kg/m	lbs/ft
ULTRA PERFORMANCE HOMOPOLYMER DELRIN® <b>UP</b>	STAINLESS STEEL	UP 828 K 3 ¼	UP828KD/000	82,6	3.25	4,0	0.16	2000	450	1,01	0.68
		UP 828 K 83,8	UP828KRA/000	83,8	3.30	4,0	0.16	2000	450	1,02	0.69
		UP 828 K 4 ½	UP828KG/000	114,3	4.50	4,0	0.16	2000	450	1,18	0.79
SPECIAL DELRIN® REINFORCED WITH KEVLAR® <b>DK2</b>	STAINLESS STEEL	D2K 828 K 3 ¼	D2K828KD/000	82,6	3.25	4,0	0.16	2000	450	1,01	0.68
		D2K 828 K 83,8	D2K828KRA/000	83,8	3.30	4,0	0.16	2000	450	1,02	0.69
		D2K 828 K 4 ½	D2K828KG/000	114,3	4.50	4,0	0.16	2000	450	1,18	0.79
<b>NEW</b> ECOLOGICAL FRICTION ABATING THERMOPLASTIC <b>e-FAST</b>	STAINLESS STEEL	EF 828 K 3 ¼	EF828KD/000	82,6	3.25	4,0	0.16	2000	450	1,01	0.68
		EF 828 K 83,8	EF828KRA/000	83,8	3.30	4,0	0.16	2000	450	1,02	0.69
		EF 828 K 4 ½	EF828KG/000	114,3	4.50	4,0	0.16	2000	450	1,18	0.79
ABRASION RESISTANT POLYAMIDE* <b>AR</b>	STAINLESS STEEL	AR 828 K 3 ¼	AR828KD/000	82,6	3.25	4,0	0.16	2000	450	0,98	0.66
		AR 828 K 4 ½	AR828KG/000	114,3	4.50	4,0	0.16	2000	450	1,12	0.75

\*Actual width is larger than the nominal width.



Standard packaging:  
Rolls of 3,048 m (10 feet)

**SINGLE HINGE**  
**REINFORCED TOP PLATE**  
**PITCH 1 ½" (38,1 mm)**  
**THICKNESS 4,8 mm (0.189")**  
**HINGE 41,6 mm (1.638")**

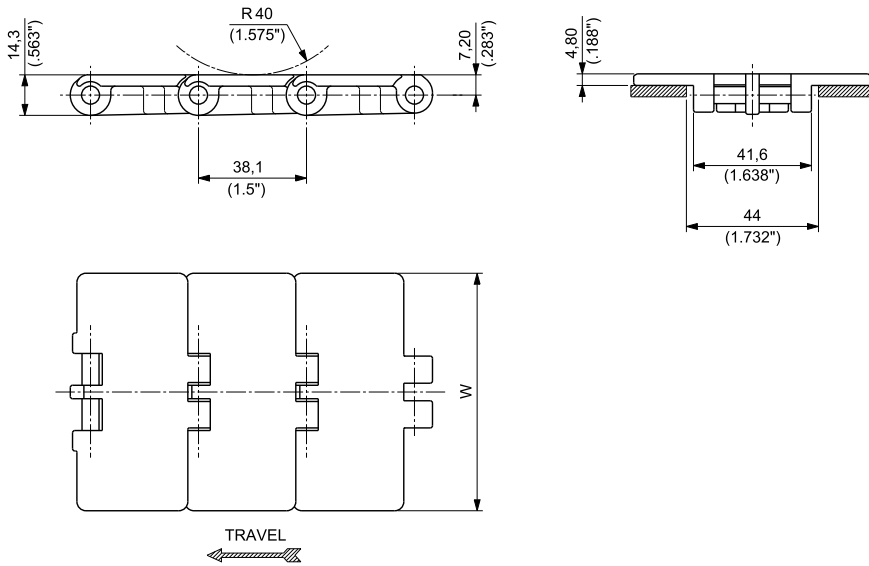

Materials  
see page 12



Sprockets  
see pages 141÷144



Applications  
see page 20

MATERIALS		ITEM DESCRIPTION	PART NUMBER	WIDTH W		PLATE THICKNESS		WORKING LOAD (25°C/77°F)		WEIGHT	
Plate	Pin			mm	inch	mm	inch	N	lbs	kg/m	lbs/ft
ULTRA PERFORMANCE HOMOPOLYMER DELRIN® <b>UP</b>	AUSTENITIC STAINLESS STEEL	UP 831 K 3 ¼	UP831KD/000	82,6	3.25	4,8	0.19	1600	360	0,90	0.60
		UP 831 K 83,8	UP831KRA/000	83,8	3.30	4,8	0.19	1600	360	0,91	0.61
		UP 831 K 4 ½	UP831KG/000	114,3	4.50	4,8	0.19	1600	360	1,09	0.73
		UP 831 K 7 ½	UP831KL/000	190,5	7.50	4,8	0.19	1600	360	1,51	1.01
SPECIAL DELRIN® REINFORCED WITH KEVLAR® <b>DK2</b>	AUSTENITIC STAINLESS STEEL	D2K 831 K 3 ¼	D2K831KD/000	82,6	3.25	4,8	0.19	1600	360	0,88	0.59
		D2K 831 K 83,8	D2K831KRA/000	83,8	3.30	4,8	0.19	1600	360	0,89	0.60
		D2K 831 K 4 ½	D2K831KG/000	114,3	4.50	4,8	0.19	1600	360	1,06	0.72
		D2K 831 K 7 ½	D2K831KL/000	190,5	7.50	4,8	0.19	1600	360	1,33	0.90



Standard packaging:  
Rolls of 3,048 m (10 feet)



**DOUBLE HINGE**  
**REINFORCED TOP PLATE**  
**PITCH 1 ½" (38,1 mm)**  
**THICKNESS 4,8 mm (0.189")**  
**HINGE 136,5 mm (5.374")**

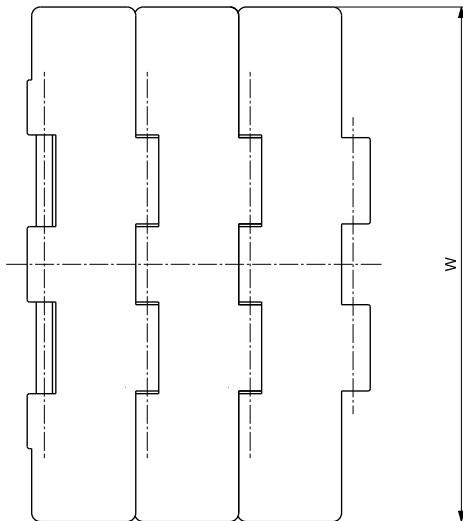
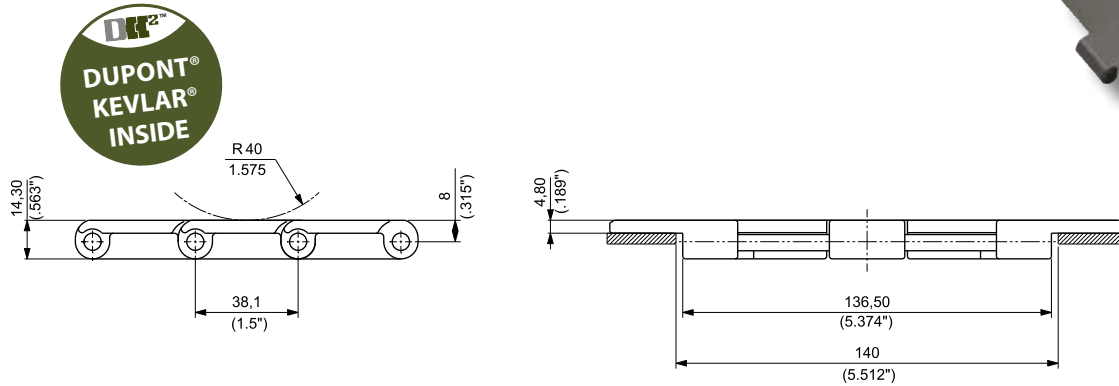
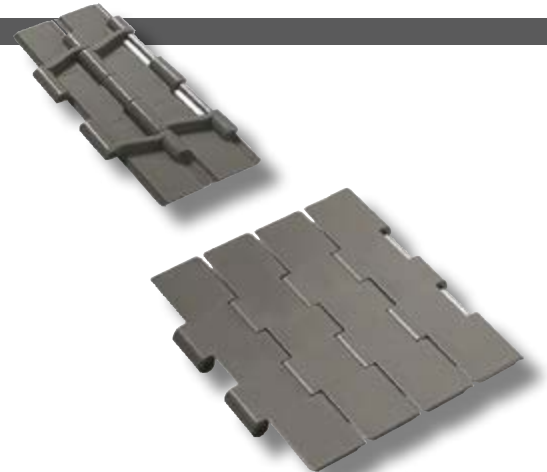

TRAVEL



Materials  
see page 12



Sprockets  
see pages 145-146



Applications  
see page 20

MATERIALS		ITEM DESCRIPTION	PART NUMBER	WIDTH W		PLATE THICKNESS		WORKING LOAD (25°C/77°F)		WEIGHT	
Plate	Pin			mm	inch	mm	inch	N	lbs	kg/m	lbs/ft
		UP 821 K 7 ½	UP821KL/000	190,5	7.50	4,8	0.19	2750	618	2,48	1.67
ULTRA PERFORMANCE HOMOPOLYMER DELRIN® <b>UP</b>	AUSTENITIC STAINLESS STEEL	UP 821 K 10	UP821KM/000	254,0	10.00	4,8	0.19	2750	618	2,86	1.92
		UP 821 K 12	UP821KN/000	304,8	12.00	4,8	0.19	2750	618	3,16	2.12
SPECIAL DELRIN® REINFORCED WITH KEVLAR® <b>D2K</b>	AUSTENITIC STAINLESS STEEL	D2K 821 K 7 ½	D2K821KL/000	190,5	7.50	4,8	0.19	2750	618	2,47	1.66



Standard packaging:  
Rolls of 3,048 m (10 feet)

**HEAVY DUTY SINGLE HINGE**  
**REINFORCED TOP PLATE**  
**PITCH 1 1/2" (38,1 mm)**  
**THICKNESS 4,8 mm (0.189")**  
**HINGE 57 mm (2.244")**

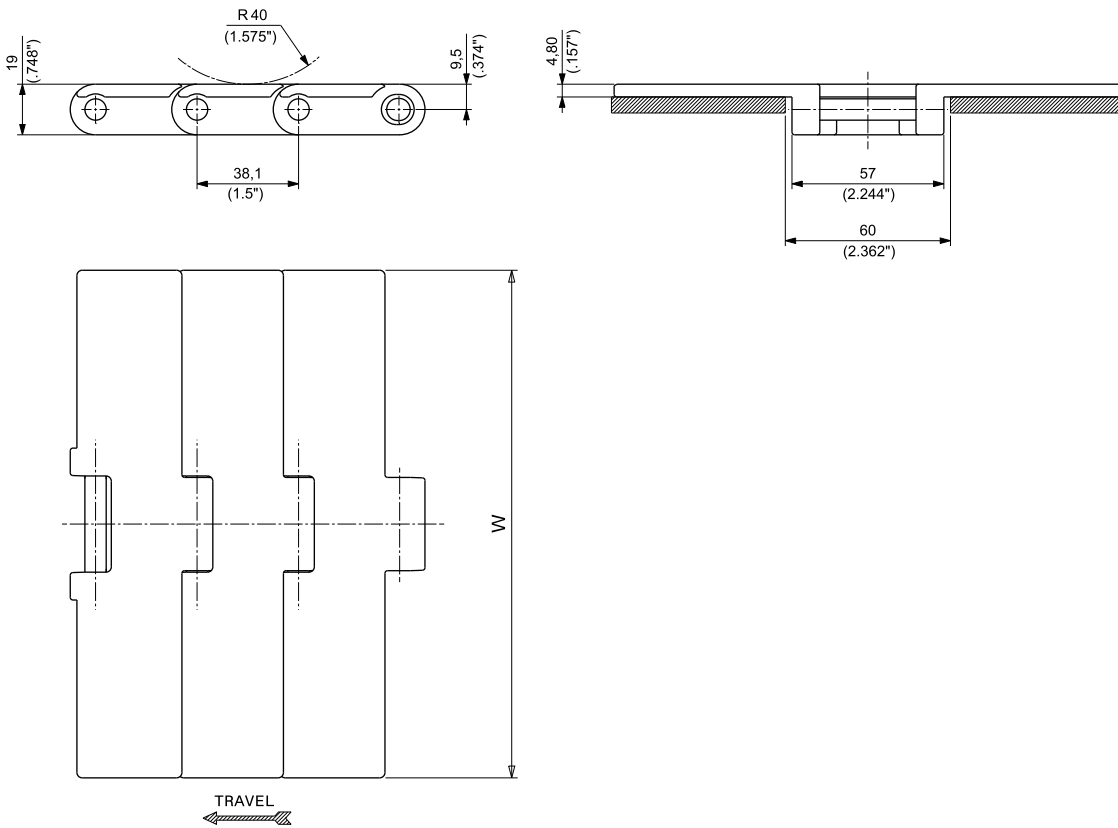

Materials  
see page 12



Sprockets  
see pages 150÷151



Applications  
see page 20

MATERIALS		ITEM DESCRIPTION	PART NUMBER	WIDTH W		PLATE THICKNESS		WORKING LOAD (25°C/77°F)		WEIGHT	
Plate	Pin			mm	inch	mm	inch	N	lbs	kg/m	lbs/ft
ULTRA PERFORMANCE HOMOPOLYMER DELRIN® <b>UP</b>	AUSTENITIC STAINLESS STEEL	UP 8257 K 7 1/2	UP8257KL/000	190,5	7.50	4,8	0.19	3910	879	2,35	1.58
		UP 8257 K 10	UP8257KM/000	254,0	10.00	4,8	0.19	3910	879	2,74	1.84



Standard packaging:  
Rolls of 3,048 m (10 feet)

## BEVEL

PITCH 1 1/2" (38,1 mm)

THICKNESS 4 mm (0.157")

HINGE 43 mm (1.693")

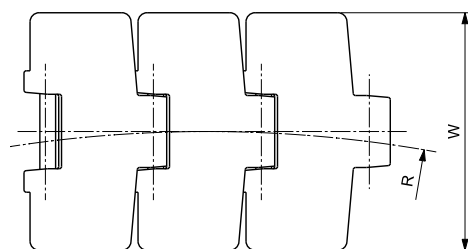
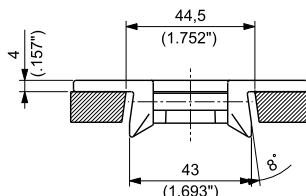
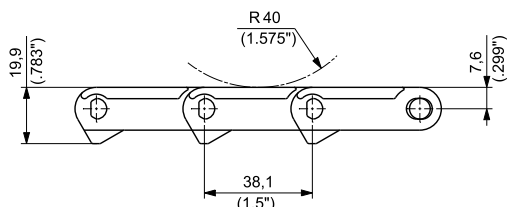

TRAVEL  
←



Materials  
see page 12



Sprockets  
see pages 147÷149



Corner tracks  
see page 325



Applications  
see page 20

MATERIALS		ITEM DESCRIPTION	PART NUMBER	WIDTH W		PLATE THICKNESS		SIDEFLEXING RADIUS		WORKING LOAD (25°C/77°F)		WEIGHT	
Plate	Pin			mm	inch	mm	inch	mm	inch	N	lbs	kg/m	lbs/ft
ULTRA PERFORMANCE HOMOPOLYMER DELRIN® <b>UP</b>	AUSTENITIC STAINLESS STEEL	UP 880 K 3 1/4	UP880KD/000	82,6	3.25	4,0	0.16	457,2	18.00	2000	450	0,90	0.61
		UP 880 K 4 1/2	UP880KG/000	114,3	4.50	4,0	0.16	500,0	19.69	2000	450	1.06	0.71
ABRASION RESISTANT POLYAMIDE* <b>AR</b>	AUSTENITIC STAINLESS STEEL	AR 880 K 3 1/4	AR880KD/000	82,6	3.25	4,0	0.16	457,2	18.00	2000	450	0,76	0.51
		AR 880 K 4 1/2	AR880KG/000	114,3	4.50	4,0	0.16	500,0	19.69	2000	450	1,04	0.70

\*Actual width is larger than the nominal width.



Standard packaging:  
Rolls of 3,048 m (10 feet)

**TAB**  
**PITCH 1 ½" (38,1 mm)**  
**THICKNESS 4 mm (0.157")**  
**HINGE 42,9 mm (1.689")**

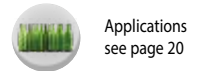
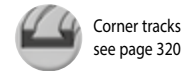
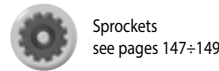
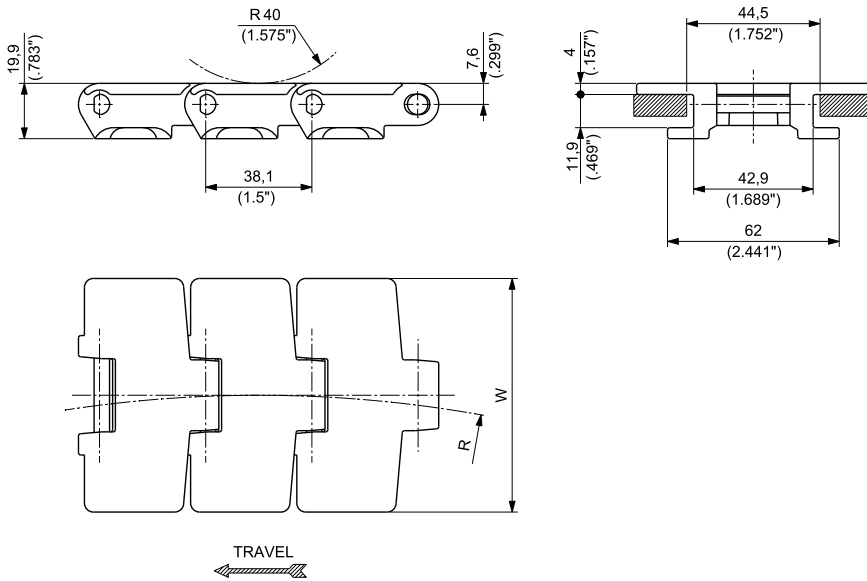

MATERIALS		ITEM DESCRIPTION	PART NUMBER	WIDTH W		PLATE THICKNESS		SIDEFLEXING RADIUS R		WORKING LOAD (25°C/77°F)		WEIGHT	
Plate	Pin			mm	inch	mm	inch	mm	inch	N	lbs	kg/m	lbs/ft
ULTRA PERFORMANCE HOMOPOLYMER DELRIN® <b>UP</b>	AUSTENITIC STAINLESS STEEL	UP 880T K 3 ¼	UP880TKD/000	82,6	3.25	4,0	0.16	457,2	18.00	2000	450	1,05	0.71
		UP 880T K 83,8	UP880TKRA/000	83,8	3.30	4,0	0.16	457,2	18.00	2000	450	1,06	0.71
		UP 880T K 4 ½	UP880TKG/000	114,3	4.50	4,0	0.16	500,0	19.69	2000	450	1,24	0.83
SPECIAL DELRIN® REINFORCED WITH KEVLAR® <b>DK2</b>	AUSTENITIC STAINLESS STEEL	D2K 880T K 3 ¼	D2K880TKD/000	82,6	3.25	4,0	0.16	457,2	18.00	2000	450	1,03	0.69
		D2K 880T K 83,8	D2K880TKRA/000	83,8	3.30	4,0	0.16	457,2	18.00	2000	450	1,04	0.70
		D2K 880T K 4 ½	D2K880TKG/000	114,3	4.50	4,0	0.16	500,0	19.69	2000	450	1,22	0.82
<b>NEW</b> ECOLOGICAL FRICTION ABATING THERMOPLASTIC <b>e-FAST</b>	AUSTENITIC STAINLESS STEEL	EF 880T K 3 ¼	EF880TKD/000	82,6	3.25	4,0	0.16	457,2	18.00	2000	450	1,03	0.69
		EF 880T K 83,8	EF880TKRA/000	83,8	3.30	4,0	0.16	457,2	18.00	2000	450	1,04	0.70
		EF 880T K 4 ½	EF880TKG/000	114,3	4.50	4,0	0.16	500,0	19.69	2000	450	1,22	0.82
ABRASION RESISTANT POLYAMIDE* <b>AR</b>	AUSTENITIC STAINLESS STEEL	AR 880T K 3 ¼	AR880TKD/000	82,6	3.25	4,0	0.16	457,2	18.00	2000	450	0,89	0.60
		AR 880T K 4 ½	AR880TKG/000	114,3	4.50	4,0	0.16	500,0	19.69	2000	450	1,02	0.69

\*Actual width is larger than the nominal width.

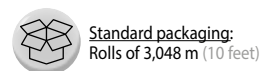

**MAGNETIC**  
**REDUCED PLATE GAP**  
**PITCH 1 ½" (38,1 mm)**  
**THICKNESS 4 mm (0.157")**  
**HINGE 42 mm (1.654")**

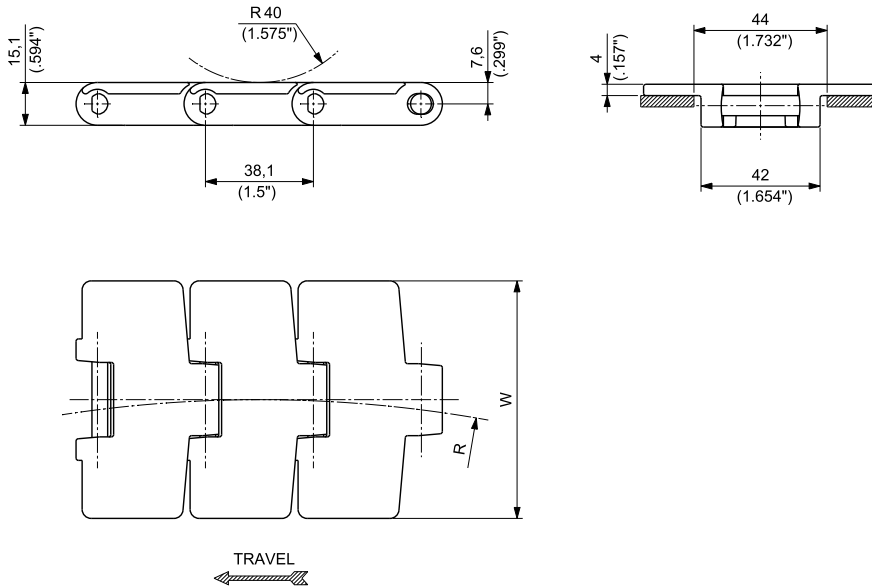

Materials  
see page 12



Sprockets  
see pages 147+149



Corner tracks  
see pages 280



Applications  
see page 20

MATERIALS		ITEM DESCRIPTION	PART NUMBER	WIDTH W		PLATE THICKNESS		SIDEFLEXING RADIUS		WORKING LOAD (25°C/77°F)		WEIGHT	
Plate	Pin			mm	inch	mm	inch	mm	inch	N	lbs	kg/m	lbs/ft
<b>UP</b> ULTRA PERFORMANCE HOMOPOLYMER DELRIN®	MAGNETIC STAINLESS STEEL	UP 880M RG K 3 ¼	UP880MRGKD/000	82,6	3.25	4,0	0.16	500,0	19.69	2000	450	0,98	0.66
		UP 880M RG K 83,8	UP880MRGKRA/000	83,8	3.30	4,0	0.16	500,0	19.69	2000	450	0,99	0.67
		UP 880M RG K 4 ½	UP880MRGKG/000	114,3	4.50	4,0	0.16	500,0	19.69	2000	450	1,12	0.75
<b>DK2</b> SPECIAL DELRIN® REINFORCED WITH KEVLAR®	MAGNETIC STAINLESS STEEL	D2K 880M RG K 3 ¼	D2K880MRGKD/000	82,6	3.25	4,0	0.16	500,0	19.69	2000	450	0,97	0.65
		D2K 880M RG K 83,8	D2K880MRGKRA/000	83,8	3.30	4,0	0.16	500,0	19.69	2000	450	0,98	0.66
		D2K 880M RG K 4 ½	D2K880MRGKG/000	114,3	4.50	4,0	0.16	500,0	19.69	2000	450	1,12	0.75
<b>e-FAST</b> ECOLOGICAL FRICTION ABATING THERMOPLASTIC	MAGNETIC STAINLESS STEEL	EF 880M RG K 3 ¼	EF880MRGKD/000	82,6	3.25	4,0	0.16	500,0	19.69	2000	450	0,97	0.65
		EF 880M RG K 83,8	EF880MRGKRA/000	83,8	3.30	4,0	0.16	500,0	19.69	2000	450	0,98	0.66
		EF 880M RG K 4 ½	EF880MRGKG/000	114,3	4.50	4,0	0.16	500,0	19.69	2000	450	1,12	0.75
<b>AR</b> ABRASION RESISTANT POLYAMIDE*	MAGNETIC STAINLESS STEEL	AR 880M RG K 4 ½	AR880MRGKG/000	114,3	4.50	4,0	0.16	500,0	19.69	2000	450	1,08	0.73



Standard packaging:  
Rolls of 3,048 m (10 feet)



**BEVEL**  
**REINFORCED TOP PLATE**  
**PITCH 1 ½" (38,1 mm)**  
**THICKNESS 4,8 mm (0.188")**  
**HINGE 43 mm (1.693")**

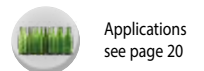
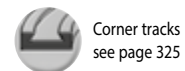
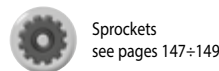
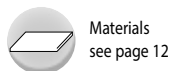
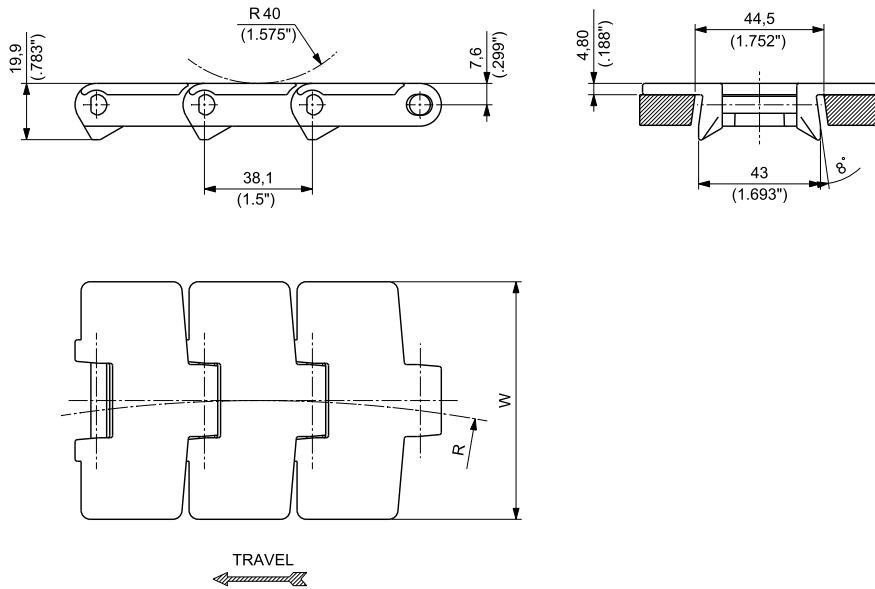
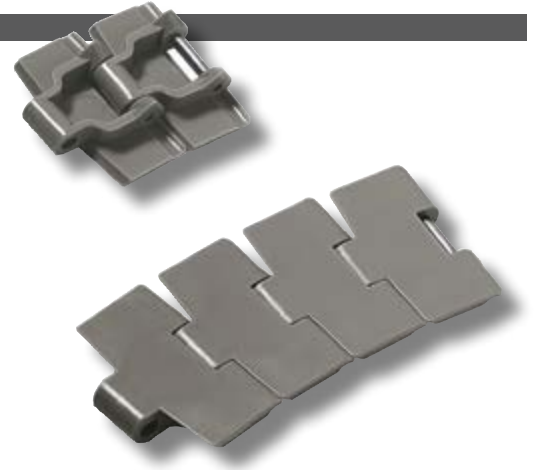

MATERIALS		ITEM DESCRIPTION	PART NUMBER	WIDTH W		PLATE THICKNESS		SIDEFLEXING RADIUS R		WORKING LOAD (25°C/77°F)		WEIGHT	
Plate	Pin			mm	inch	mm	inch	mm	inch	N	lbs	kg/m	lbs/ft
ULTRA PERFORMANCE HOMOPOLYMER DELRIN®	AUSTENITIC STAINLESS STEEL	UP 879 K 3 ¼	UP879KD/000	82,6	3.25	4,8	0.19	457,2	18.00	2000	450	0,96	0.65
<b>UP</b>		UP 879 K 4 ½	UP879KG/000	114,3	4.50	4,8	0.19	500,0	19.69	2000	450	1,11	0.75

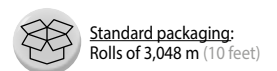

**TAB**  
**REINFORCED TOP PLATE**  
**PITCH 1 ½" (38,1 mm)**  
**THICKNESS 4,8 mm (0.188")**  
**HINGE 42,9 mm (1.689")**

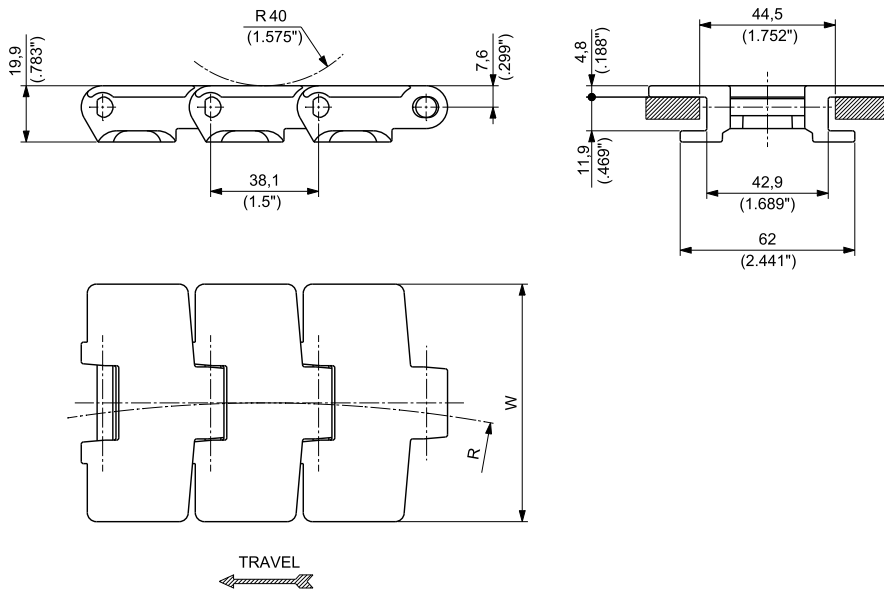

FliteTop



Materials  
see page 12



Sprockets  
see pages 147÷149



Corner tracks  
see page 320



Applications  
see page 20

MATERIALS		ITEM DESCRIPTION	PART NUMBER	WIDTH W		PLATE THICKNESS		SIDEFLEXING RADIUS R		WORKING LOAD (25°C/77°F)		WEIGHT	
Plate	Pin			mm	inch	mm	inch	mm	inch	N	lbs	kg/m	lbs/ft
ULTRA PERFORMANCE HOMOPOLYMER DELRIN® <b>UP</b>	AUSTENITIC STAINLESS STEEL	UP 879T K 3 ¼	UP879TKD/000	82,6	3.25	4,8	0.19	457,2	18.00	2000	450	1,07	0.72
		UP 879T K 83,8	UP879TKRA/000	83,8	3.30	4,8	0.19	457,2	18.00	2000	450	1,08	0.73
		UP 879T K 4 ½	UP879TKG/000	114,3	4.50	4,8	0.19	500,0	19.69	2000	450	1,28	0.86
SPECIAL DELRIN® REINFORCED WITH KEVLAR® <b>D2K</b>	AUSTENITIC STAINLESS STEEL	D2K 879T K 3 ¼	D2K879TKD/000	82,6	3.25	4,8	0.19	457,2	18.00	2000	450	1,04	0.70
		D2K 879T K 83,8	D2K879TKRA/000	83,8	3.30	4,8	0.19	457,2	18.00	2000	450	1,05	0.71
		D2K 879T K 4 ½	D2K879TKG/000	114,3	3.30	4,8	0.19	500,0	19.69	2000	450	1,24	0.83



Standard packaging:  
Rolls of 3,048 m (10 feet)

**BEVEL**  
**HEAVY DUTY SINGLE HINGE**  
**REINFORCED TOP PLATE**  
**PITCH 1 ½" (38,1 mm)**  
**THICKNESS 4,8 mm (0.189")**  
**HINGE 61 mm (2.402")**

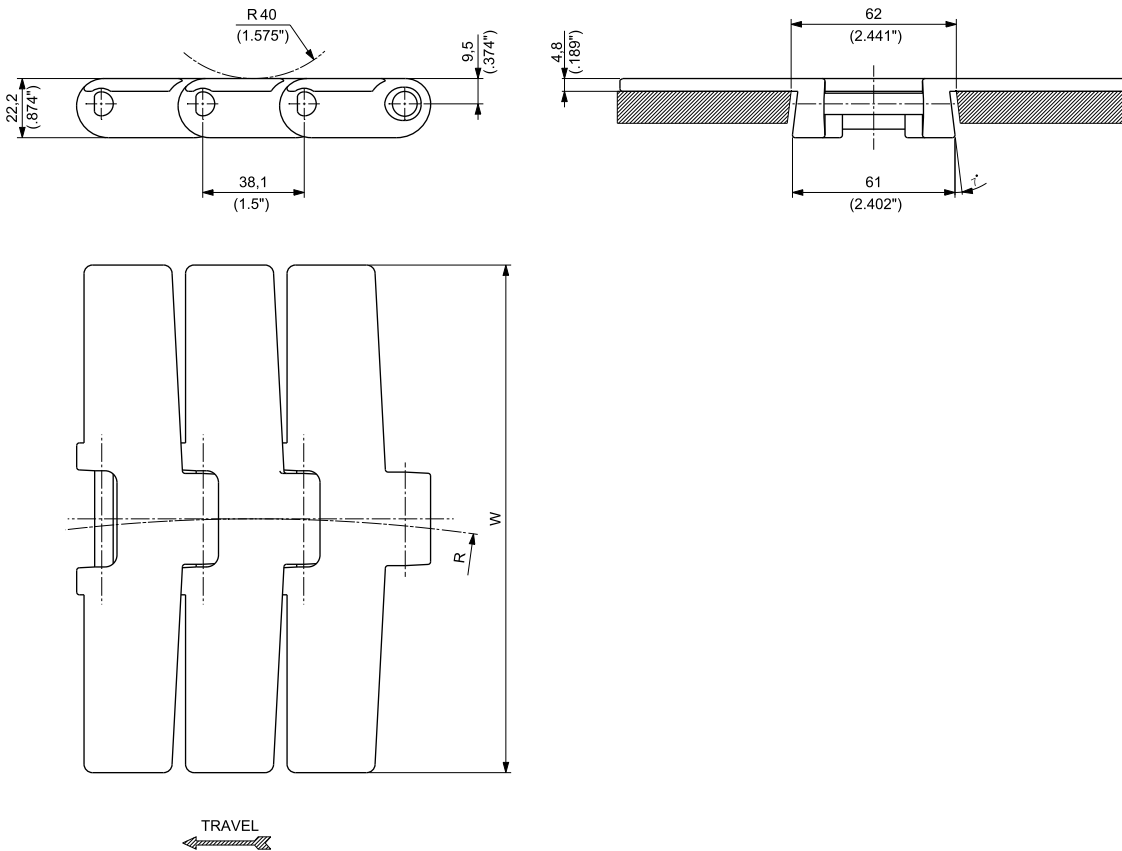

Materials  
see page 12



Sprockets  
see pages 150÷151



Corner tracks  
see page 326



Applications  
see page 20

MATERIALS		ITEM DESCRIPTION	PART NUMBER	WIDTH W		PLATE THICKNESS		SIDEFLEXING RADIUS		WORKING LOAD (25°C/77°F)		WEIGHT	
Plate	Pin			mm	inch	mm	inch	mm	R inch	N	lbs	kg/m	lbs/ft
ULTRA PERFORMANCE HOMOPOLYMER DELRIN® <b>UP</b>	AUSTENITIC STAINLESS STEEL	UP 882 K 4 ½	UP882KG/000	114,3	4.50	4,8	0.19	609,6	24	3910	879	1,92	1.29
		UP 882 K 7 ½	UP882KL/000	190,5	7.50	4,8	0.19	609,6	24	3910	879	2,31	1.55
		UP 882 K 10	UP882KM/000	254,0	10.00	4,8	0.19	609,6	24	3910	879	2,62	1.76
		UP 882 K 12	UP882KN/000	304,8	12.00	4,8	0.19	609,6	24	3910	879	2,85	1.91



Standard packaging:  
Rolls of 3,048 m (10 feet)

**TAB**  
**HEAVY DUTY SINGLE HINGE**  
**REINFORCED TOP PLATE**  
**PITCH 1 ½" (38,1 mm)**  
**THICKNESS 4,8 mm (0.189")**  
**HINGE 57 mm (2.244")**

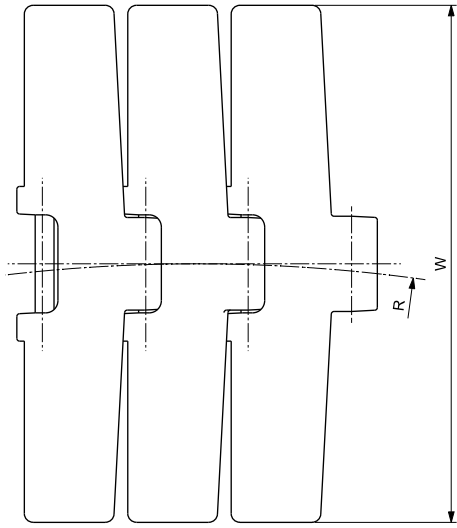
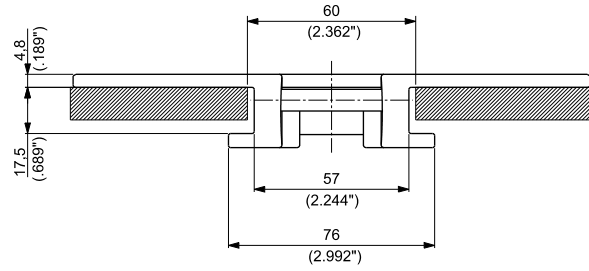
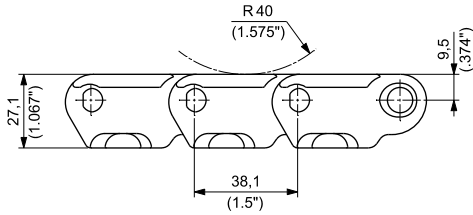
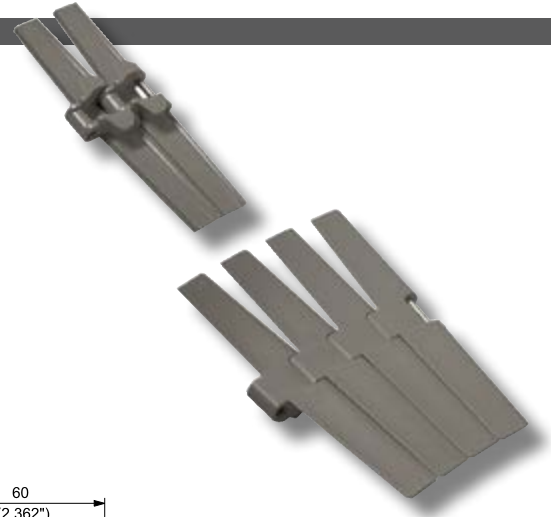

FliteTop



Materials see page 12



Sprockets see pages 150÷152



Corner tracks see page 321



Applications see page 20

MATERIALS		ITEM DESCRIPTION	PART NUMBER	WIDTH W		PLATE THICKNESS		SIDEFLEXING RADIUS		WORKING LOAD (25°C/77°F)		WEIGHT	
Plate	Pin			mm	inch	mm	inch	mm	R inch	N	lbs	kg/m	lbs/ft
ULTRA PERFORMANCE HOMOPOLYMER DELRIN® <b>UP</b>	AUSTENITIC STAINLESS STEEL	UP 882T K 4 ½	UP882TKG/000	114,3	4.50	4,8	0.19	609,6	24	3910	879	2,05	1.38
		<b>NEW</b> UP 882T K 6	UP882TKH/000	152,4	6.00	4,8	0.19	609,6	24	3910	879	2,25	1.51
		UP 882T K 7 ½	UP882TKL/000	190,5	7.50	4,8	0.19	609,6	24	3910	879	2,45	1.64
		UP 882T K 10	UP882TKM/000	254,0	10.00	4,8	0.19	609,6	24	3910	879	2,75	1.85
		UP 882T K 12	UP882TKN/000	304,8	12.00	4,8	0.19	609,6	24	3910	879	2,99	2.01
SPECIAL DELRIN® REINFORCED WITH KEVLAR® <b>DUPONT</b>	AUSTENITIC STAINLESS STEEL	<b>NEW</b> D2K 882T K 4 ½	D2K882TKG/000	114,3	4.50	4,8	0.19	609,6	24	3910	879	2,05	1.38
		D2K 882T K 6	D2K882TKH/000	152,4	6.00	4,8	0.19	609,6	24	3910	879	2,25	1.51
		<b>NEW</b> D2K 882T K 7 ½	D2K882TKL/000	190,5	7.50	4,8	0.19	609,6	24	3910	879	2,45	1.64
ECOLOGICAL FRICTION ABATING THERMOPLASTIC <b>E-F.A.S.T.</b>	AUSTENITIC STAINLESS STEEL	EF 882T K 4 ½	EF882TKG/000	114,3	4.50	4,8	0.19	609,6	24	3910	879	2,05	1.38



Standard packaging:  
Rolls of 3,048 m (10 feet)

**MAGNETIC  
HEAVY DUTY SINGLE HINGE  
REINFORCED TOP PLATE  
PITCH 1 ½" (38,1 mm)  
THICKNESS 4,8 mm (0.189")  
HINGE 57 mm (2.244")**

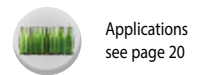
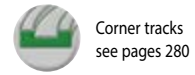
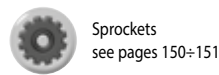
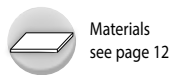
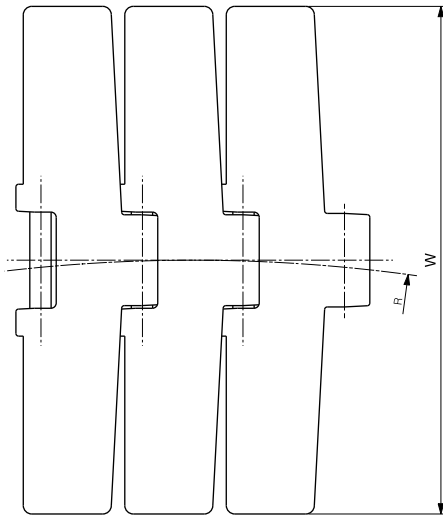
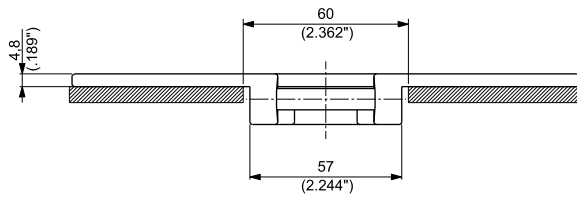
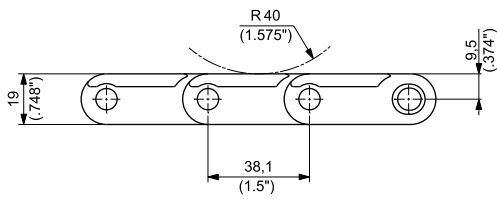

MATERIALS		ITEM DESCRIPTION	PART NUMBER	WIDTH W		PLATE THICKNESS		SIDEFLEXING RADIUS		WORKING LOAD (25°C/77°F)		WEIGHT	
Plate	Pin			mm	inch	mm	inch	mm	R inch	N	lbs	kg/m	lbs/ft
ULTRA PERFORMANCE HOMOPOLYMER DELRIN® <b>UP</b>	MAGNETIC STAINLESS STEEL	UP 882M K 7 ½	UP882MKL/000	190,5	7.50	4,8	0.19	609,6	24	3910	879	2,21	1.48
		UP 882M K 10	UP882MKM/000	254,0	10.00	4,8	0.19	609,6	24	3910	879	2,52	1.69
		UP 882M K 12	UP882MKN/000	304,8	12.00	4,8	0.19	609,6	24	3910	879	2,76	1.85

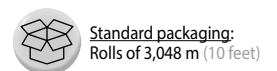



**TAB**  
**REDUCED SIDEFLEXING RADIUS**  
**REINFORCED TOP PLATE**  
**PITCH 1 1/2" (38,1 mm)**  
**THICKNESS 4,8 mm (0.189")**  
**HINGE 42,9 mm (1.689")**

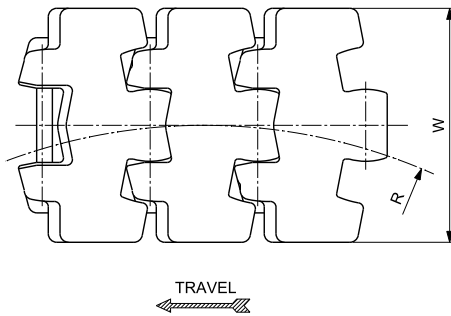
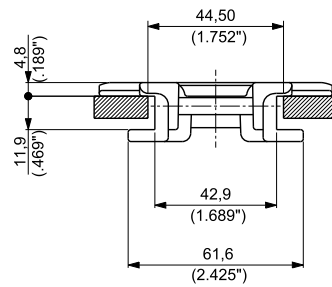
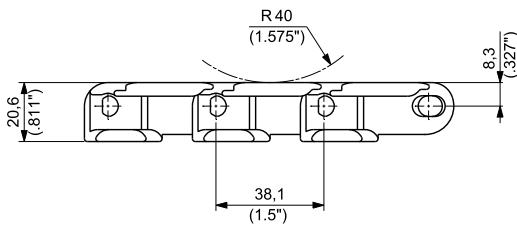

Materials  
see page 12



Sprockets  
see pages 147+149



Corner tracks  
see page 320



Applications  
see page 20

MATERIALS		ITEM DESCRIPTION	PART NUMBER	WIDTH W		PLATE THICKNESS		SIDEFLEXING RADIUS		WORKING LOAD (25°C/77°F)		WEIGHT	
Plate	Pin			mm	inch	mm	inch	mm	R inch	N	lbs	kg/m	lbs/ft
ULTRA PERFORMANCE HOMOPOLYMER DELRIN® <b>UP</b>	AUSTENITIC STAINLESS STEEL	UP 878T K 3 1/4	UP878TKD/000	82,6	3.25	4,8	0.19	200	7.87	2000	450	1,08	0.73
SPECIAL DELRIN® REINFORCED WITH KEVLAR® <b>DK2</b>	AUSTENITIC STAINLESS STEEL	D2K 878T K 3 1/4	D2K878TKD/000	82,6	3.25	4,8	0.19	200	7.87	2000	450	1,06	0.71
ABRASION RESISTANT POLYAMIDE* <b>AR</b>	AUSTENITIC STAINLESS STEEL	AR 878T K 3 1/4	AR878TKD/000	82,6	3.25	4,8	0.19	200	7.87	2000	450	0,89	0.60

\*Actual width is larger than the nominal width.



Standard packaging:  
Rolls of 3,048 m (10 feet)

**TAB**  
**VACUUM SERIES**  
**PITCH 1 ½" (38,1 mm)**  
**THICKNESS 4 mm (0.157")**  
**HINGE 42,9 mm (1.689")**

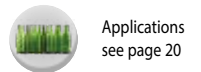
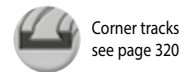
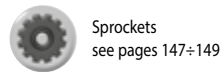
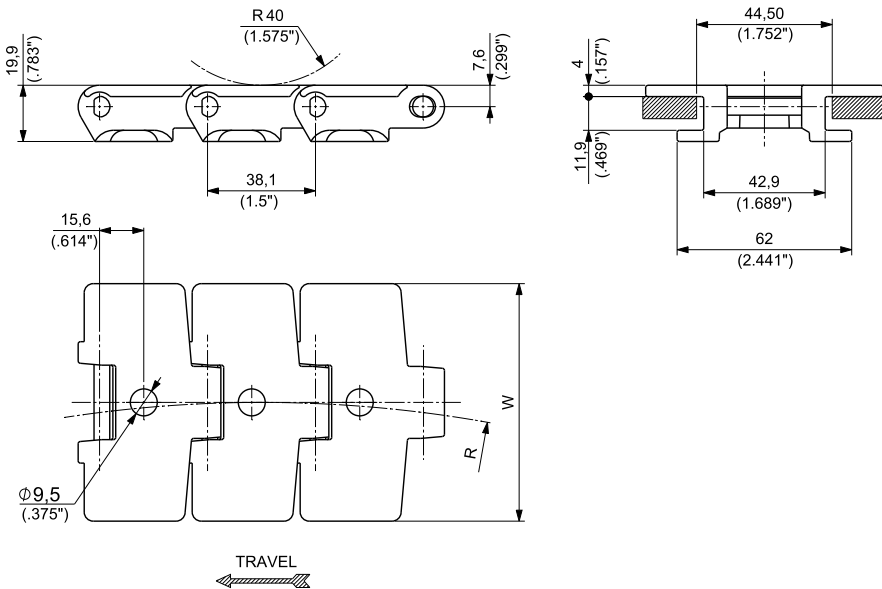

MATERIALS		ITEM DESCRIPTION	PART NUMBER	WIDTH W		PLATE THICKNESS		SIDEFLEXING RADIUS R		WORKING LOAD (25°C/77°F)		WEIGHT	
Plate	Pin			mm	inch	mm	inch	mm	inch	N	lbs	kg/m	lbs/ft
ULTRA PERFORMANCE HOMOPOLYMER DELRIN® <b>UP</b>	AUSTENITIC STAINLESS STEEL	UP 880TA K 3 ¼	UP880TAKD/000	82,6	3.25	4,0	0.16	457,2	18	2000	450	0,51	0.34

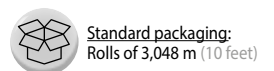



PERFORMANCE IN MOTION

***FliteTop***<sup>®</sup>

Rubberized Surface  
Plastic Chains

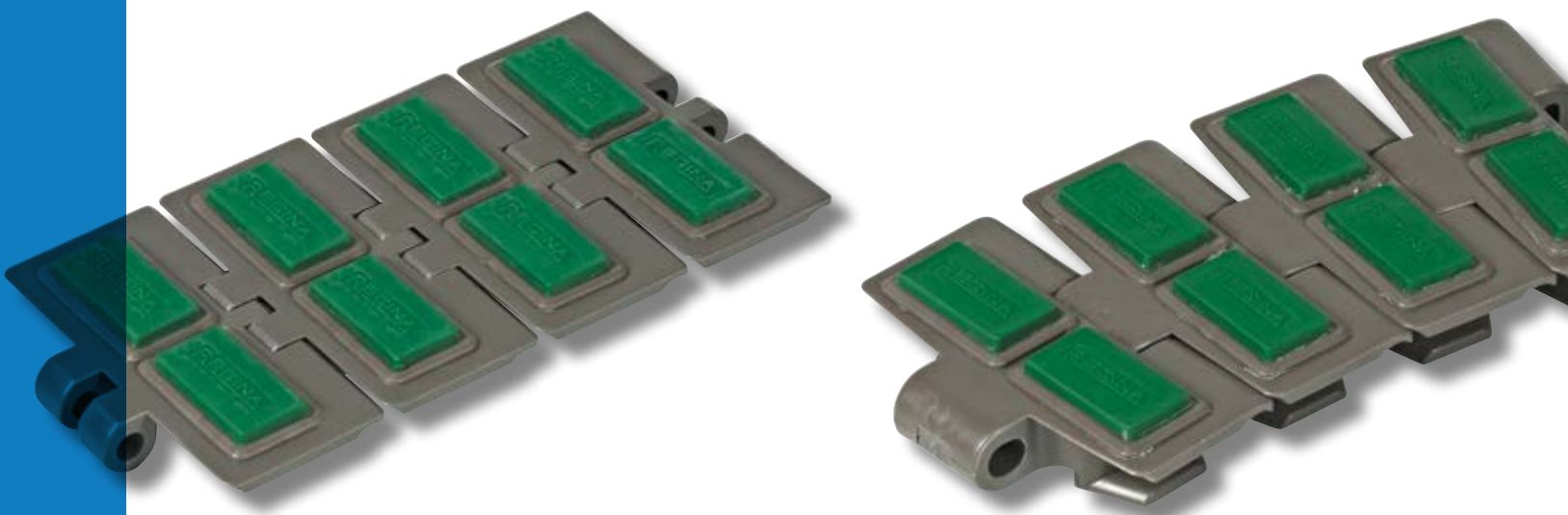

## SINGLE HINGE

PITCH 1 1/2" (38,1 mm)

THICKNESS 4 mm (0.157")

HINGE 41,6 mm (1.638")

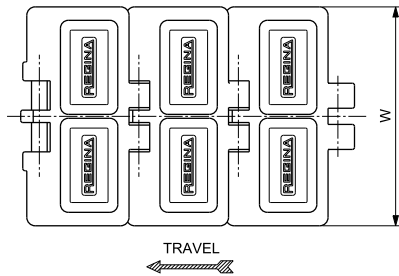
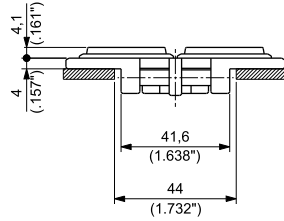
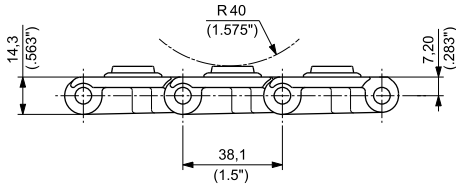
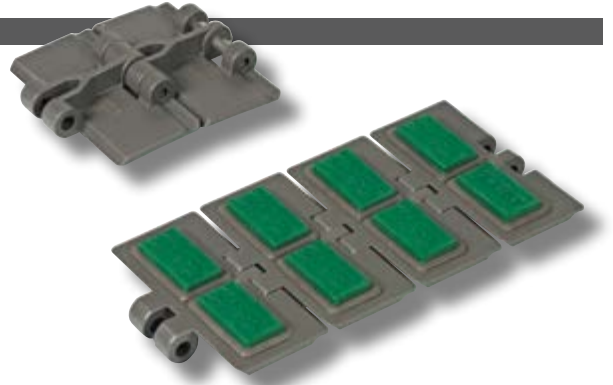

### RUBBER PAD POSITION

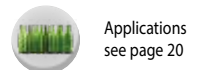
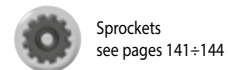
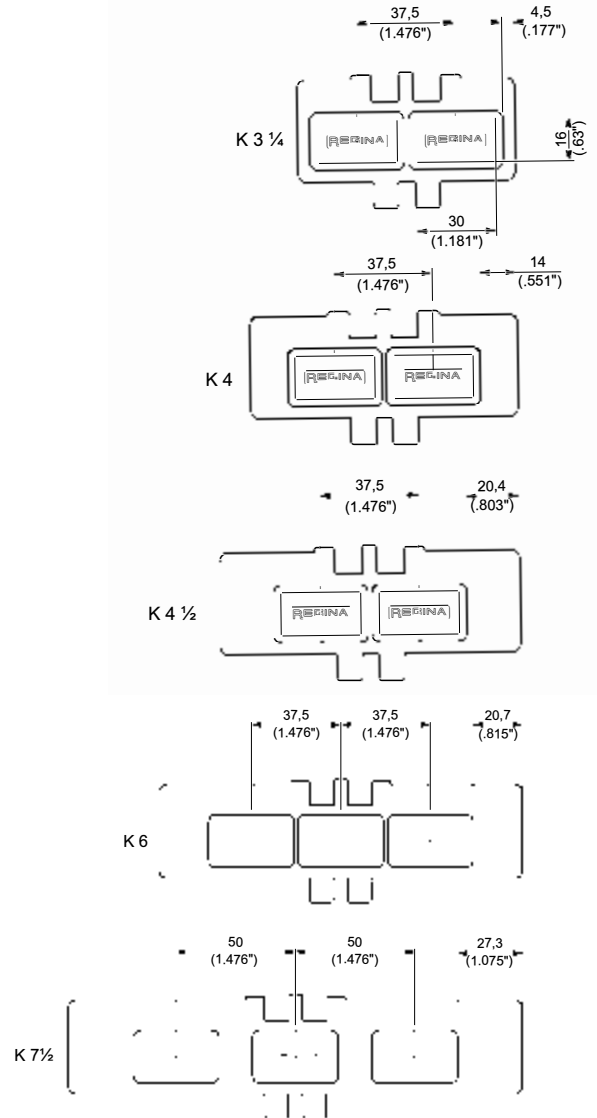

MATERIALS			ITEM DESCRIPTION	PART NUMBER	WIDTH W		PLATE THICKNESS		WORKING LOAD (25°C/77°F)		WEIGHT	
Plate	Pin	Rubber			mm	inch	mm	inch	N	lbs	kg/m	lbs/ft
ULTRA PERFORMANCE HOMOPOLYMER DELRIN® <b>UP</b>	AUSTENITIC STAINLESS STEEL	THERMOPLASTIC <b>TPE</b> Hardness: 70 Sha	HFX 820 UP K 3 1/4	HFX820KD/000	82,6	3.25	4,0	0.16	1600	360	1,00	0.67
			HFX 820 UP K 4	HFX820KF/000	101,6	4.00	4,0	0.16	1600	360	1,09	0.73
			HFX 820 UP K 4 1/2	HFX820KG/000	114,3	4.50	4,0	0.16	1600	360	1,17	0.79
			HFX 820 UP K 6	HFX820KH/000	152,4	6.00	4,0	0.16	1600	360	1,45	0.97
			HFX 820 UP K 7 1/2	HFX820KL/000	190,5	7.50	4,0	0.16	1600	360	1,60	1.07

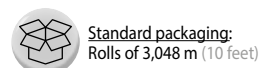

**DOUBLE HINGE**  
**REINFORCED TOP PLATE**  
**PITCH 1 ½" (38,1 mm)**  
**THICKNESS 4,8 mm (0.189")**  
**HINGE 136,5 mm (5.374")**

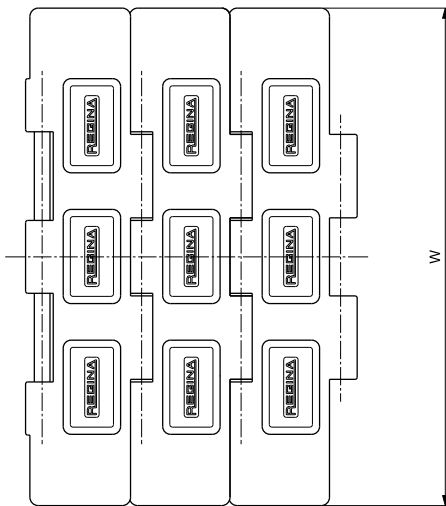
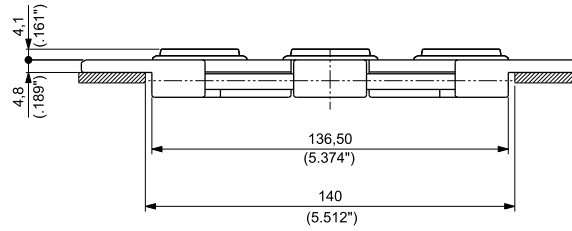
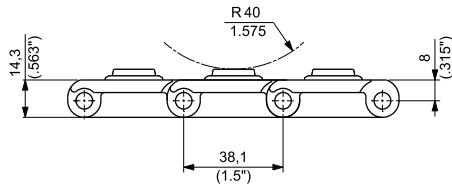
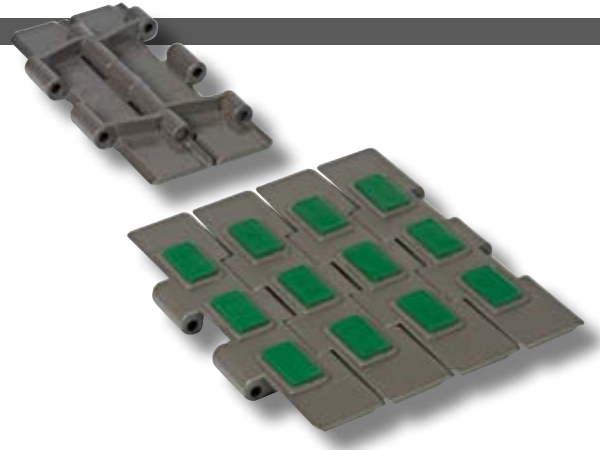

### RUBBER PAD POSITION

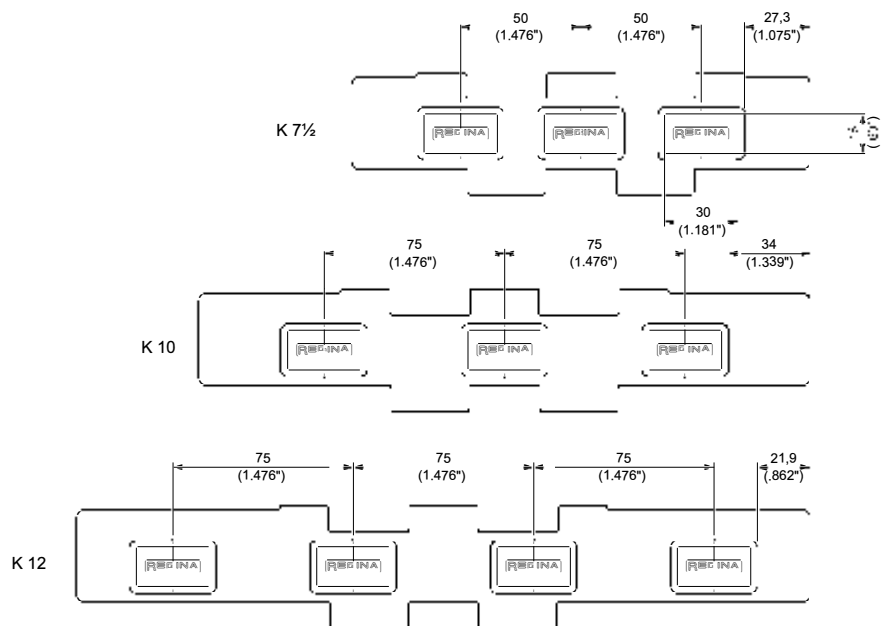

Materials  
see page 12



Sprockets  
see pages 145÷146



Applications  
see page 20

MATERIALS			ITEM DESCRIPTION	PART NUMBER	WIDTH W		PLATE THICKNESS		WORKING LOAD (25°C/77°F)		WEIGHT	
Plate	Pin	Rubber			mm	inch	mm	inch	N	lbs	kg/m	lbs/ft
ULTRA PERFORMANCE HOMOPOLYMER DELRIN® <b>UP</b>	AUSTENITIC STAINLESS STEEL	THERMOPLASTIC	HFX 821 UP K 7 ½	HFX821KL/000	190,5	7.50	4,8	0.19	2750	618	2,68	1.80
		<b>TPE</b>	HFX 821 UP K 10	HFX821KM/000	254,0	10.00	4,8	0.19	2750	618	3,06	2.06
		Hardness: 70 Sha	HFX 821 UP K 12	HFX821KN/000	304,8	12.00	4,8	0.19	2750	618	3,43	2.30



Standard packaging:  
Rolls of 3,048 m (10 feet)

**HEAVY DUTY SINGLE HINGE  
REINFORCED TOP PLATE  
PITCH 1 ½" (38,1 mm)  
THICKNESS 4,8 mm (0.189")  
HINGE 57 mm (2.244")**

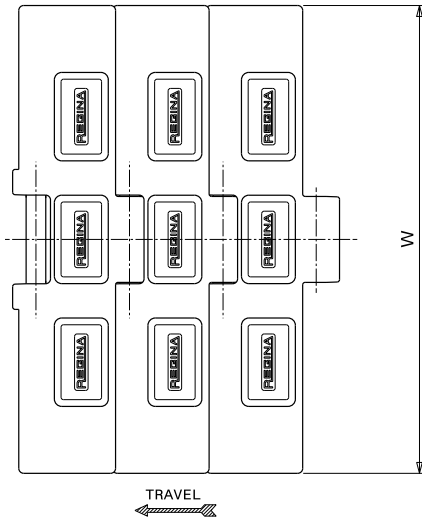
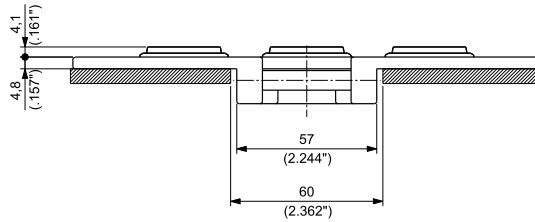
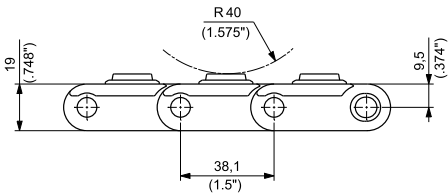
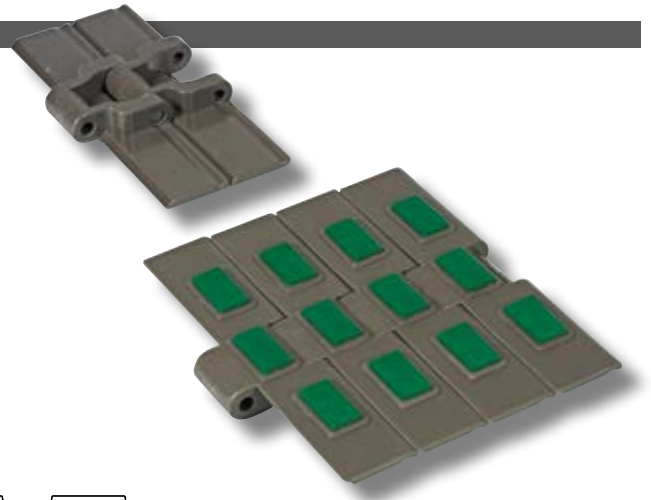

**RUBBER PAD POSITION**

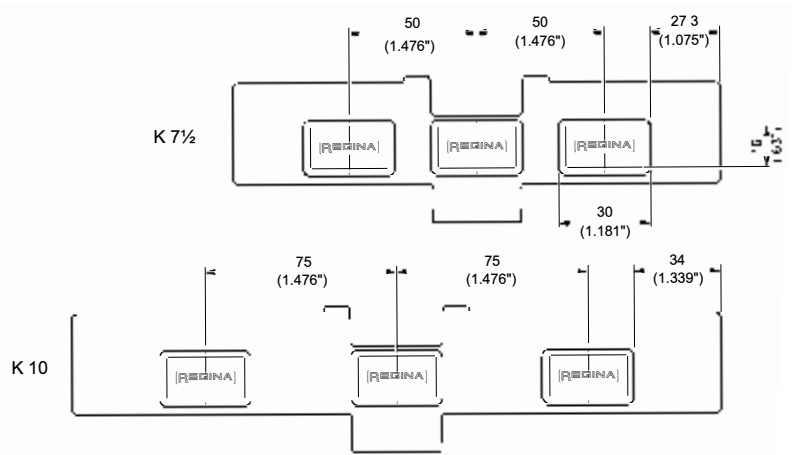

Materials  
see page 12

Sprockets  
see pages 150+151

Applications  
see page 20

MATERIALS			ITEM DESCRIPTION	PART NUMBER	WIDTH W		PLATE THICKNESS		WORKING LOAD (25°C/77°F)		WEIGHT	
Plate	Pin	Rubber			mm	inch	mm	inch	N	lbs	kg/m	lbs/ft
ULTRA PERFORMANCE HOMOPOLYMER DELRIN® <b>UP</b>	AUSTENITIC STAINLESS STEEL	THERMOPLASTIC <b>TPE</b> Hardness: 70 Sha	HFX 8257 UP K 7 ½	HFX8257UPKL/000	190,5	7.50	4,8	0.19	3910	879	2,68	1.80
			HFX 8257 UP K 10	HFX8257UPKM/000	254,0	10.00	4,8	0.19	3910	879	3,06	2.06

Standard packaging:  
Rolls of 3,048 m (10 feet)



**TAB**  
**PITCH 1 1/2" (38,1 mm)**  
**THICKNESS 4 mm (0.157")**  
**HINGE 42,9 mm (1.689")**

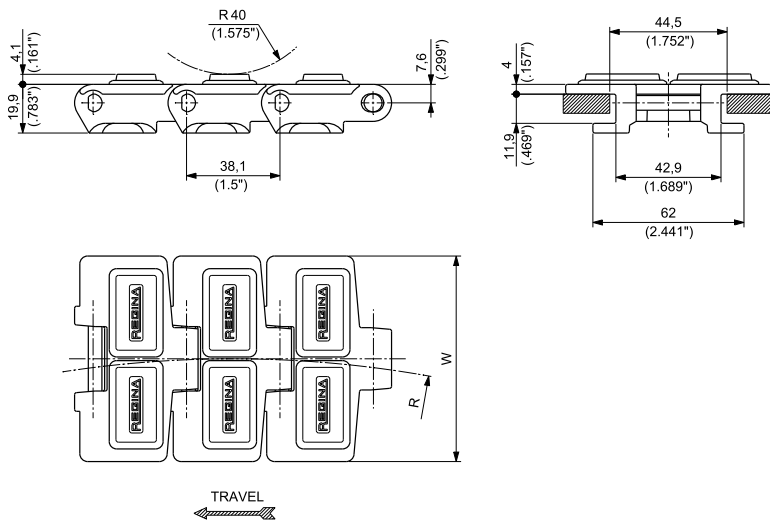
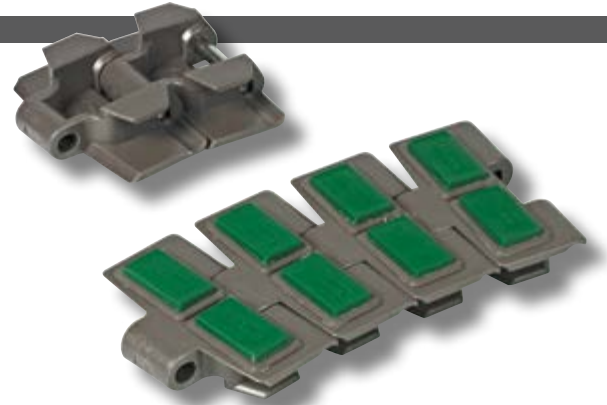

### RUBBER PAD POSITION

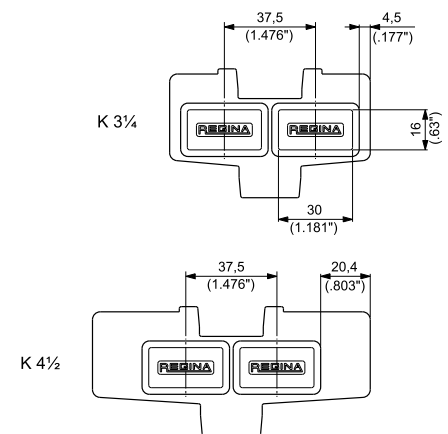

Materials  
see page 12



Sprockets  
see pages 147÷149



Corner tracks  
see page 320



Applications  
see page 20

MATERIALS			ITEM DESCRIPTION	PART NUMBER	WIDTH W		PLATE THICKNESS		SIDEFLEXING RADIUS		WORKING LOAD (25°C/77°F)		WEIGHT	
Plate	Pin	Rubber			mm	inch	mm	inch	mm <sup>R</sup>	Inch	N	lbs	kg/m	lbs/ft
ULTRA PERFORMANCE HOMOPOLYMER DELRIN <sup>®</sup> <b>UP</b>	AUSTENITIC STAINLESS STEEL	THERMOPLASTIC TPE Hardness: 70 ShA	HFX 880T UP K 3 1/4	HFX880TKD/000	82,6	3.25	4,0	0.16	500,0	19.69	2750	618	2,68	1.80
			HFX 880T UP K 4 1/2	HFX880TKG/000	114,3	4.50	4,0	0.16	500,0	19.69	2750	618	3,06	2.06



Standard packaging:  
Rolls of 3,048 m (10 feet)

**TAB**  
**HEAVY DUTY SINGLE HINGE**  
**REINFORCED TOP PLATE**  
**PITCH 1 ½" (38,1 mm)**  
**THICKNESS 4,8 mm (0.189")**  
**HINGE 57 mm (2.244")**

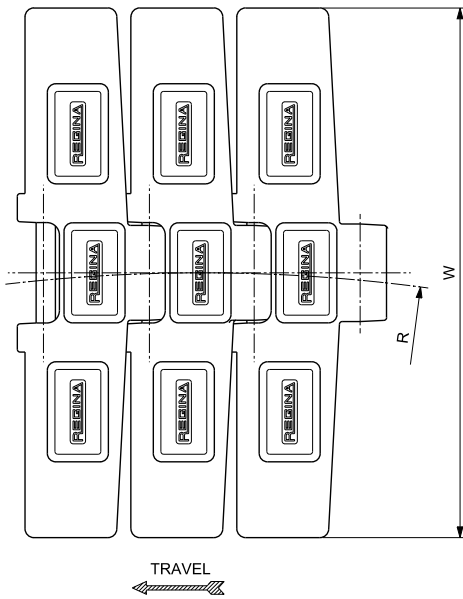
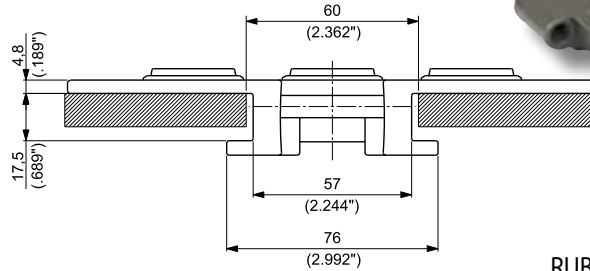
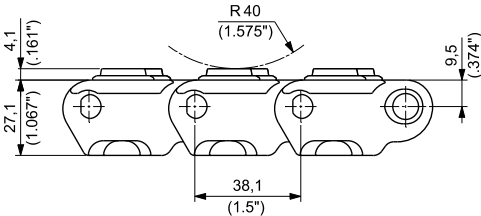
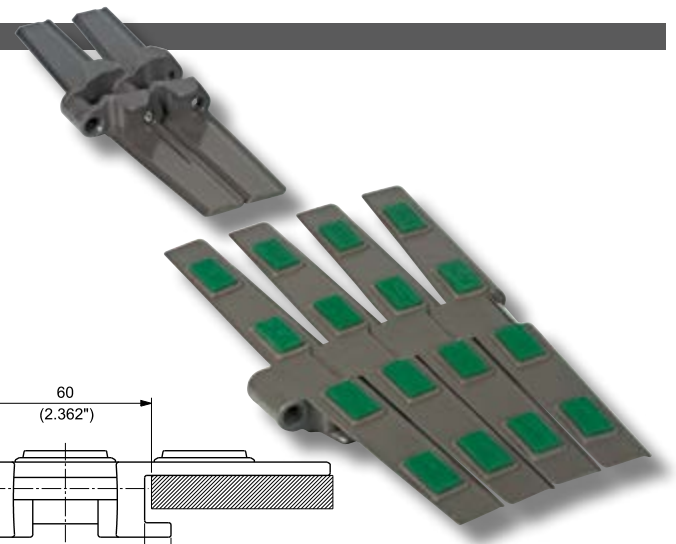

**RUBBER PAD POSITION**

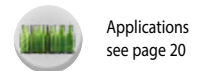
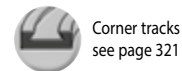
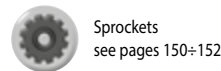
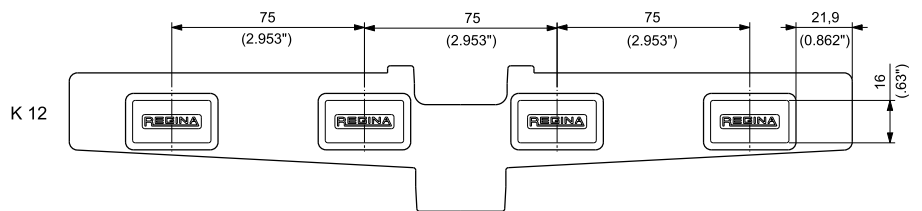
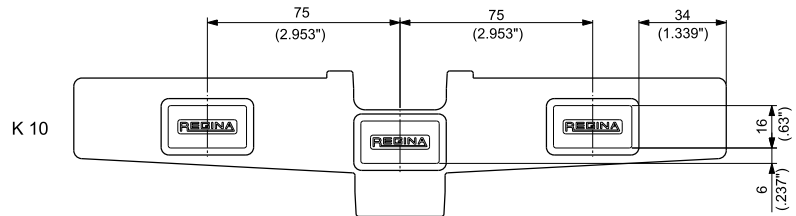
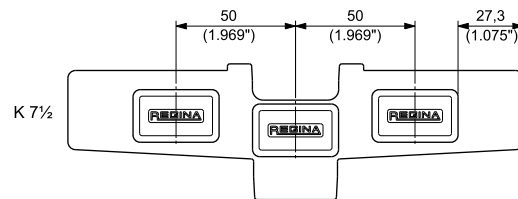
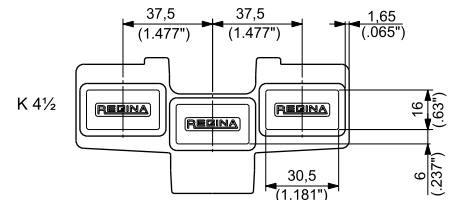

MATERIALS			ITEM DESCRIPTION	PART NUMBER	WIDTH W		PLATE THICKNESS		SIDEFLEXING RADIUS		WORKING LOAD (25°C/77°F)		WEIGHT	
Plate	Pin	Rubber			mm	inch	mm	inch	mm R	inch	N	lbs	kg/m	lbs/ft
ULTRA PERFORMANCE HOMOPOLYMER DELRIN® <b>UP</b>	AUSTENITIC STAINLESS STEEL	THERMOPLASTIC	HFX 882T UP K 4 ½	HFX882TKG/000	114,3	4.50	4,8	0.19	609,6	24	3910	879	2,25	1.71
		<b>TPE</b>	HFX 882T UP K 7 ½	HFX882TKL/000	190,5	7.50	4,8	0.19	609,6	24	3910	879	2,64	1.78
		Hardness: 70 Sha	HFX 882T UP K 10	HFX882TKM/000	254,0	10.00	4,8	0.19	609,6	24	3910	879	2,95	1.98
			HFX 882T UP K 12	HFX882TKN/000	304,8	12.00	4,8	0.19	609,6	24	3910	879	3,25	2.18

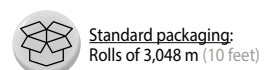

**MAGNETIC  
HEAVY DUTY SINGLE HINGE  
REINFORCED TOP PLATE  
PITCH 1 ½" (38,1 mm)  
THICKNESS 4,8 mm (0.189")  
HINGE 57 mm (2.244")**

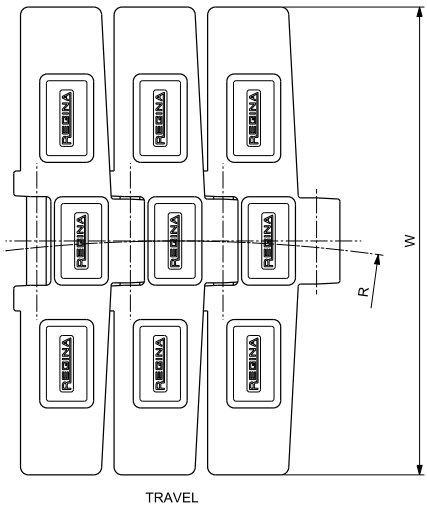
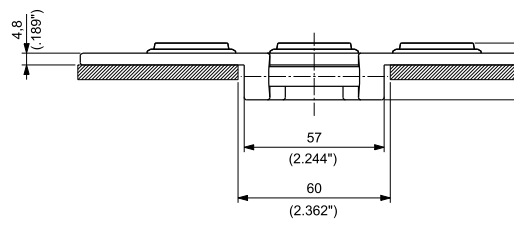
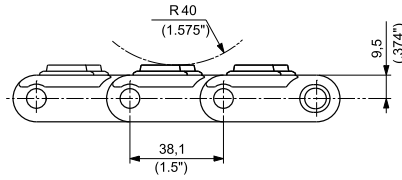
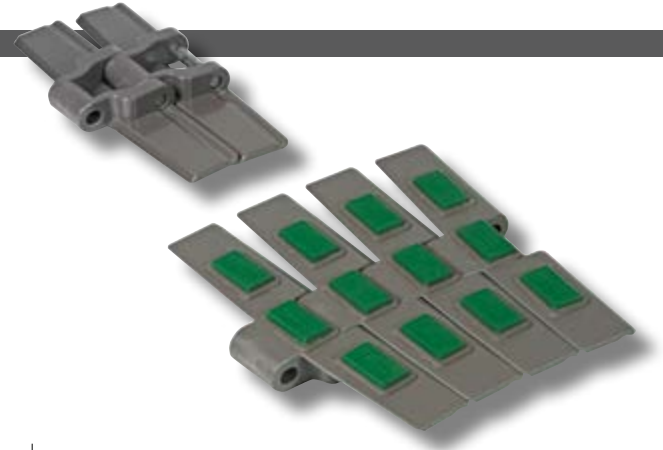

**RUBBER PAD POSITION**

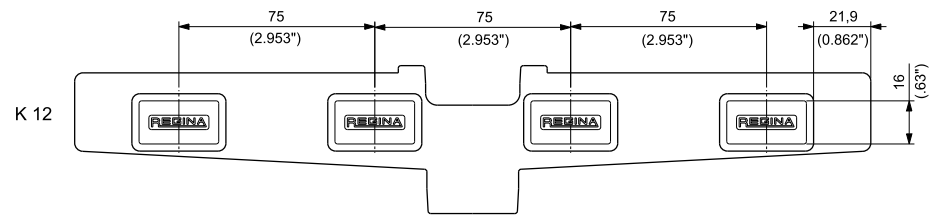
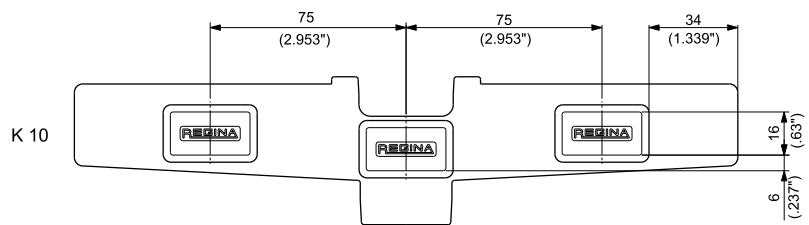
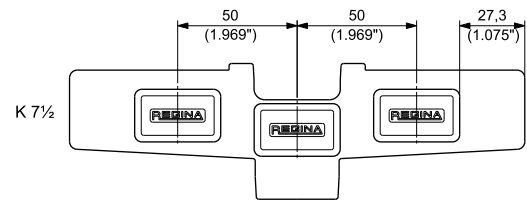

Materials see page 12



Sprockets see pages 150÷151



Corner tracks see pages 280



Applications see page 20

MATERIALS			ITEM DESCRIPTION	PART NUMBER	WIDTH W		PLATE THICKNESS		SIDEFLEXING RADIUS R		WORKING LOAD (25°C/77°F)		WEIGHT	
Plate	Pin	Rubber			mm	inch	mm	inch	mm	inch	N	lbs	kg/m	lbs/ft
ULTRA PERFORMANCE HOMOPOLYMER DELRIN® <b>UP</b>	MAGNETIC STAINLESS STEEL	THERMOPLASTIC	HFX 882M UP K 7 ½	HFX882MUPKL/000	190,5	7.50	4,8	0.19	609,6	24	3910	879	2,40	1.61
		<b>TPE</b>	HFX 882M UP K 10	HFX882MUPKM/000	254,0	10.00	4,8	0.19	609,6	24	3910	879	2,71	1.82
		Hardness: 70 ShA	HFX 882M UP K 12	HFX882MUPKN/000	304,8	12.00	4,8	0.19	609,6	24	3910	879	3,02	2.03



Standard packaging:  
Rolls of 3,048 m (10 feet)





PERFORMANCE IN MOTION

***FliteTop***<sup>®</sup>

**Two-Piece Chains**

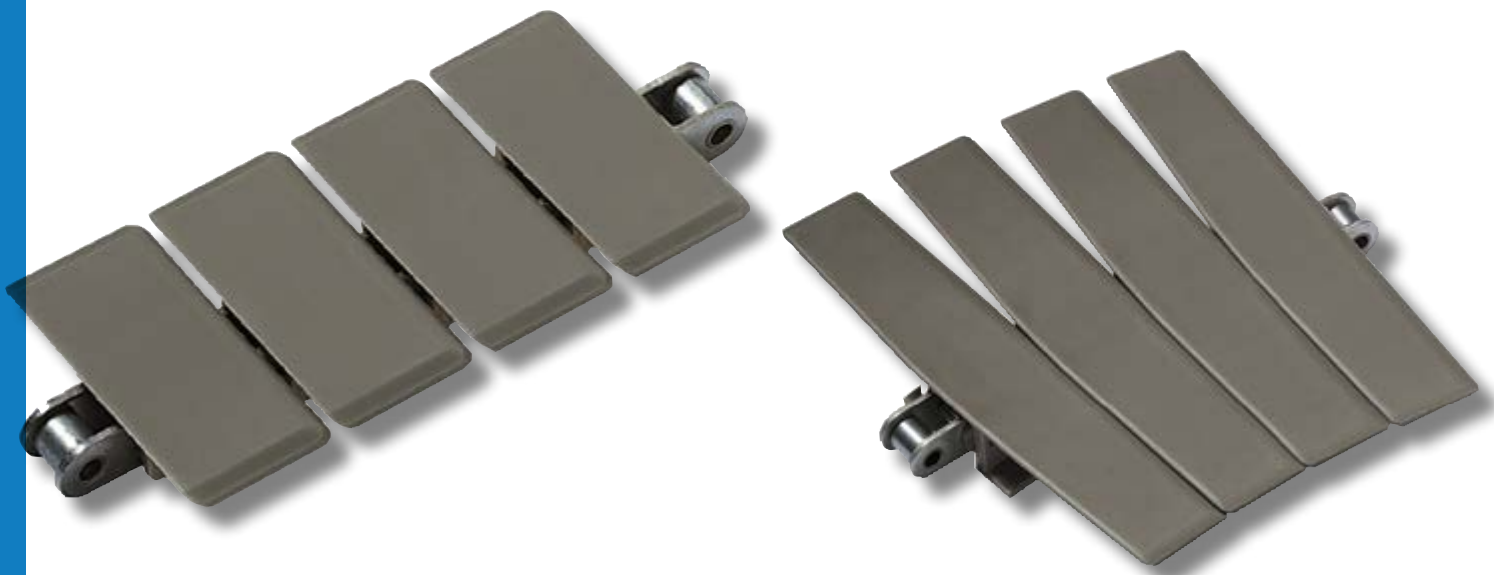

## INDUSTRIES AND APPLICATIONS

### TWO-PIECE CHAINS

Suitable for handling products (loose or packaged) where less stick slip effect and accurate product positioning (step by step applications) are required.

#### INDUSTRIES

Bottling and canning  
Container manufacturing  
Paper / Cardboard  
Glass manufacturing  
Automotive / Mechanical

#### APPLICATIONS

General single lane conveyors  
Product handling within packaging machine



## FEATURES

- Powered by ASA 40 and ASA 60 base roller chains made by REGINA in Italy.
- Stainless steel chain prelubricated with high performance lube suitable for the food industry (USDA H1 approved) which guarantees long-lasting effect for the chain.
- Great loading capacity at higher speed.
- Possibility of longer conveyor on a single drive.
- Easy replaceable top flights clipped on the protruding pins on the base roller chain.



## STEEL FLIGHTS

3/4" PITCH ROLLER CHAIN (ASA 60)

BIDIRECTIONAL

THICKNESS 3 mm (0.118")

HINGE 27 mm (1.063")

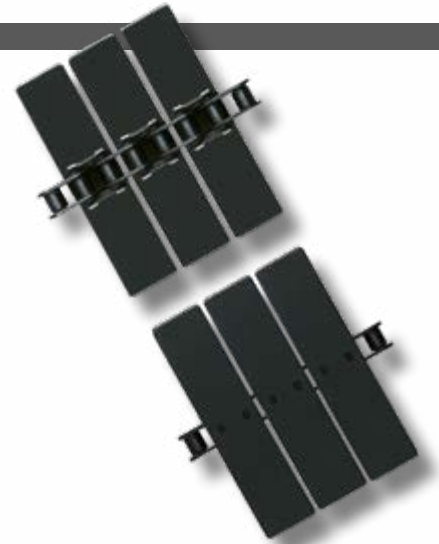

POWERED  
BY BASE ROLLER  
CHAIN MADE  
BY REGINA  
IN ITALY

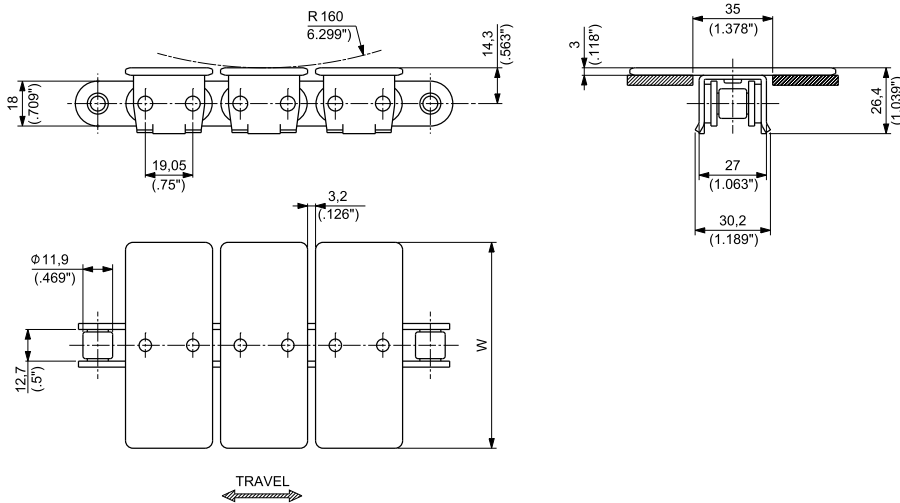





Materials  
see page 12



Sprockets  
see page 154



Applications  
see page 20

MATERIALS		ITEM DESCRIPTION	PART NUMBER	CONNECTING LINK PART NUMBER	WIDTH W		WORKING LOAD (25°C/77°F)		WEIGHT	
Flight	Base Chain				mm	inch	N	lbs	kg/m	lbs/ft
CARBON STEEL 		1864 K 3 1/4	1864KD/000	18/0864	82,6	3.25	5500	1,236	4,00	2.69
		1864 K 4 1/2	1864KG/000		114,3	4.50	5500	1,236	4,73	3.18
		1864 K 6	1864KH/000		152,4	6.00	5500	1,236	5,60	3.76
		1864 K 7 1/2	1864KL/000		190,5	7.50	5500	1,236	6,16	4.14
STAINLESS STEEL 		SS 1864 K 3 1/4	1864SSKD/000	18/SS864AB	82,6	3.25	4500	1,012	3,94	2.65
		SS 1864 K 4 1/2	1864SSKG/000		114,3	4.50	4500	1,012	4,67	3.14
		SS 1864 K 6	1864SSKH/000		152,4	6.00	4500	1,012	5,33	3.58
		SS 1864 K 7 1/2	1864SSKL/000		190,5	7.50	4500	1,012	6,09	4.10



Standard packaging:  
Rolls of 3,048 m (10 feet)

**TAB**  
**STEEL FLIGHTS**  
**3/4" PITCH ROLLER CHAIN (ASA 60 SIDEBOW)**  
**BIDIRECTIONAL**  
**THICKNESS 3 mm (0.118")**  
**HINGE 31,8 mm (1.252")**  
**1874T: FLIGHT GAP 8,2 mm**  
**1874TM: REDUCED FLIGHT GAP 5,7 mm**



**POWERED BY BASE ROLLER CHAIN MADE BY REGINA IN ITALY**

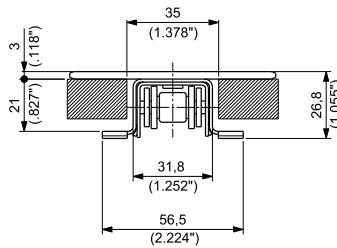
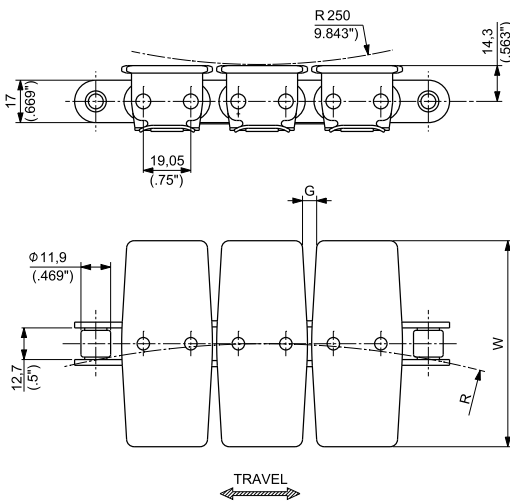

Materials see page 12



Sprockets see pages 154



Corner tracks see page 322



Applications see page 20

## 1874T

MATERIALS		ITEM DESCRIPTION	PART NUMBER	CONNECTING LINK PART NUMBER	WIDTH W		STRAIGHT RUNNING GAP G		SIDEFLEXING RADIUS R		WORKING LOAD (25°C/77°F)		WEIGHT	
Flight	Base Chain				mm	inch	mm	inch	mm	inch	N	lbs	kg/m	lbs/ft
CARBON STEEL 	CARBON STEEL 	1874T K 3 1/4	1874TKD/000	18/0873	82,6	3.25	8,2	0.323	381,0	15	4500	1,012	4,21	2.83
		1874T K 4 1/2	1874TKG/000		114,3	4.50	8,2	0.323	381,0	15	4500	1,012	4,80	3.22
		1874T K 6	1874TKH/000		152,4	6.00	8,2	0.323	457,2	18	4500	1,012	5,59	3.75
		1874T K 7 1/2	1874TKL/000		190,5	7.50	8,2	0.323	609,6	24	4500	1,012	6,31	4.24
STAINLESS STEEL 	STAINLESS STEEL 	SS 1874T K 3 1/4	1874TSSKD/000	18/SS873AB	82,6	3.25	8,2	0.323	381,0	15	3500	787	4,13	2.78
		SS 1874T K 4 1/2	1874TSSKG/000		114,3	4.50	8,2	0.323	381,0	15	3500	787	4,72	3.17
		SS 1874T K 6	1874TSSKH/000		152,4	6.00	8,2	0.323	457,2	18	3500	787	5,51	3.70
		SS 1874T K 7 1/2	1874TSSKL/000		190,5	7.50	8,2	0.323	609,6	24	3500	787	6,22	4.18

## 1874TM

MATERIALS		ITEM DESCRIPTION	PART NUMBER	CONNECTING LINK PART NUMBER	WIDTH W		STRAIGHT RUNNING GAP G		SIDEFLEXING RADIUS R		WORKING LOAD (25°C/77°F)		WEIGHT	
Flight	Base Chain				mm	inch	mm	inch	mm	inch	N	lbs	kg/m	lbs/ft
CARBON STEEL 	CARBON STEEL 	1874TM K 4 1/2	1874MLKG/000	18/0873	114,3	4.50	5,7	0.224	609,6	24	4500	1012	4,80	3.22



Standard packaging:  
Rolls of 3,048 m (10 feet)

**PLASTIC FLIGHTS**  
**1/2" PITCH ROLLER CHAIN (ASA 40)**  
**THICKNESS 3.2 mm (0.126")**  
**HINGE 20,6 mm (0.811")**

POWERED  
 BY BASE ROLLER  
 CHAIN MADE  
 BY REGINA  
 IN ITALY

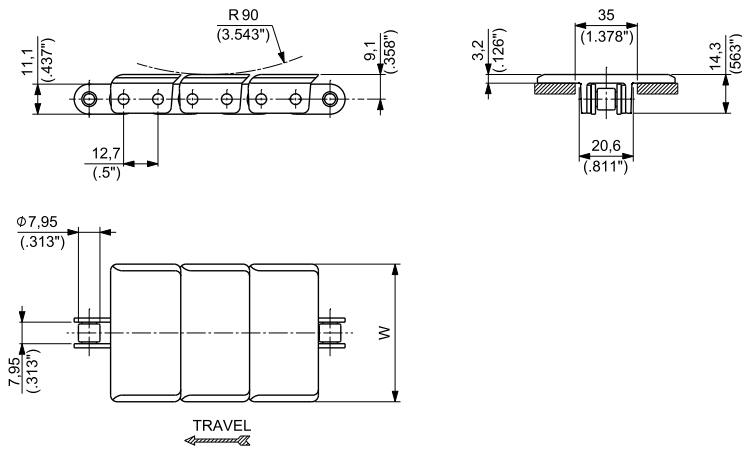
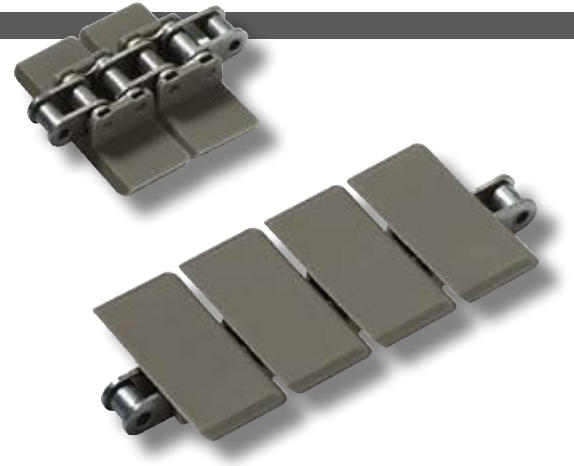

Materials  
see page 12



Sprockets  
see page 153



Applications  
see page 20

MATERIALS		ITEM DESCRIPTION	PART NUMBER	CONNECTING LINK PART NUMBER	WIDTH W		WORKING LOAD (25°C/77°F)		WEIGHT	
Flight	Base Chain				mm	inch	N	lbs	kg/m	lbs/ft
ULTRA PERFORMANCE HOMOPOLYMER DELRIN® <b>UP</b>	CARBON STEEL	UP 843 K 1 3/8	UP843KA/000	18/0843	34,9	1.37	3500	787	0,65	0.43
		UP 843 K 2	UP843KB/000		50,8	2.00	3500	787	0,71	0.48
		UP 843 K 3 1/4	UP843KD/000	18/SS843AB	82,6	3.25	3500	787	0,84	0.57
		UP 843 SS K 1 3/8	UP843SKA/000		34,9	1.37	2700	607	0,84	0.56
	STAINLESS STEEL	UP 843 SS K 2	UP843SKB/000		50,8	2.00	2700	607	0,90	0.61
		UP 843 SS K 3 1/4	UP843SKD/000		82,6	3.25	2700	607	1,03	0.69



Standard packaging:  
Rolls of 3,048 m (10 feet)

## PLASTIC FLIGHTS

1/2" PITCH ROLLER CHAIN (ASA 40)

BIDIRECTIONAL

THICKNESS 3.2 mm (0.126")

HINGE 20,6 mm (0.811")

POWERED  
BY BASE ROLLER  
CHAIN MADE  
BY REGINA  
IN ITALY

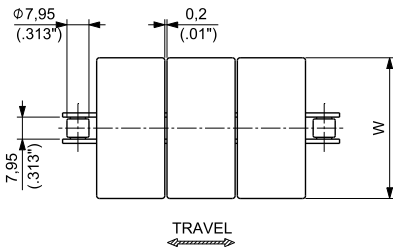
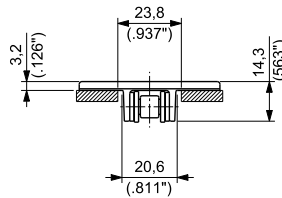
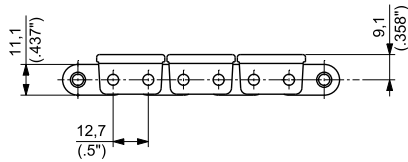

Materials  
see page 12



Sprockets  
see page 153



Applications  
see page 20

MATERIALS		ITEM DESCRIPTION	PART NUMBER	CONNECTING LINK PART NUMBER	WIDTH W		WORKING LOAD (25°C/77°F)		WEIGHT	
Flight	Base Chain				mm	inch	N	lbs	kg/m	lbs/ft
ULTRA PERFORMANCE HOMOPOLYMER DELRIN® <b>UP</b>	CARBON STEEL	UP 845 K 1 3/8	UP845KA/000	18/0843	34,9	1.37	3500	787	0,66	0.44
		UP 845 K 40	UP845KP/000		40,0	1.57	3500	787	0,69	0.46
	UP 845 K 2	UP845KB/000	50,8		2.00	3500	787	0,73	0.49	
	STAINLESS STEEL	UP 845 SS K 1 3/8	UP845SKA/000		34,9	1.37	2700	607	0,85	0.57
		UP 845 SS K 40	UP845SKP/000		18/SS843AB	40,0	1.57	2700	607	0,88
UP 845 SS K 2		UP845SKB/000	50,8	2.00		2700	607	0,92	0.62	



Standard packaging:  
Rolls of 3,048 m (10 feet)

**PLASTIC FLIGHTS**  
**½" PITCH ROLLER CHAIN (ASA 40)**  
**BIDIRECTIONAL**  
**RAISED RIB**  
**THICKNESS 12,2 mm (0.480")**  
**HINGE 20,6 mm (0.811")**



**POWERED BY BASE ROLLER CHAIN MADE BY REGINA IN ITALY**

## TRANSFER COMB

The comb is supplied with slot cover but without fastening screws. One fastening screw is required for each comb. It can be ordered using P/N 1630005.

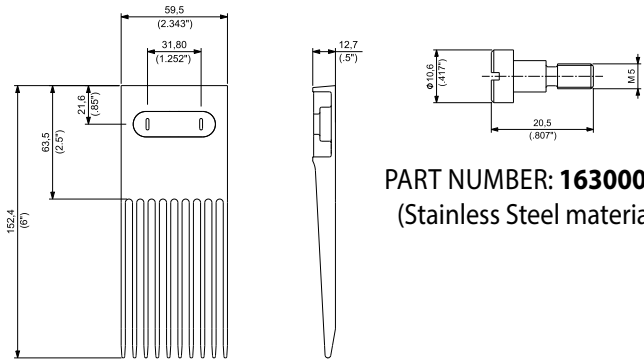
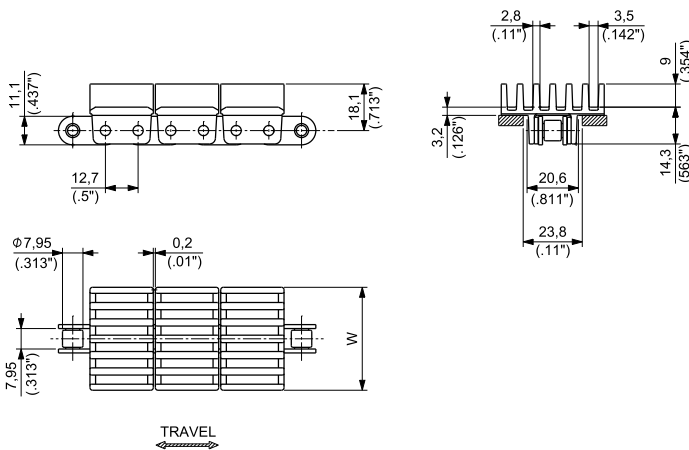

**PART NUMBER: 1630005**  
(Stainless Steel material)

**PART NUMBER: TC845-01**  
(Acetal Resin material)



Materials see page 12



Sprockets see page 153



Applications see page 20

MATERIALS		ITEM DESCRIPTION	PART NUMBER	CONNECTING LINK PART NUMBER	WIDTH W		WORKING LOAD (25°C/77°F)		WEIGHT	
Flight	Base Chain				mm	inch	N	lbs	kg/m	lbs/ft
ULTRA PERFORMANCE HOMOPOLYMER DELRIN®	CHEMICALLY NICKEL CARBON STEEL (NC)	RR 845 UP NC K 40	R845UPCKP/000	18/843-003	40,0	1.57	3500	787	0,94	0.63
<b>UP</b>		RR 845 UP NC K 53,6	R845UPCKZA/000		53,6	2.11	3500	787	1,02	0.69



Standard packaging:  
Rolls of 3,048 m (10 feet)

**PLASTIC FLIGHTS**  
**1/2" PITCH ROLLER CHAIN (ASA 40)**  
**BIDIRECTIONAL**  
**RUBBERIZED RAISED RIB**  
**THICKNESS 12,6 mm (0.496")**  
**HINGE 20,6 mm (0.811")**

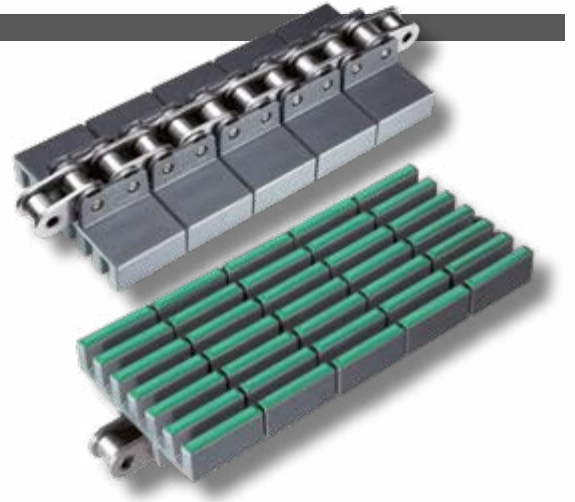

**POWERED  
 BY BASE ROLLER  
 CHAIN MADE  
 BY REGINA  
 IN ITALY**

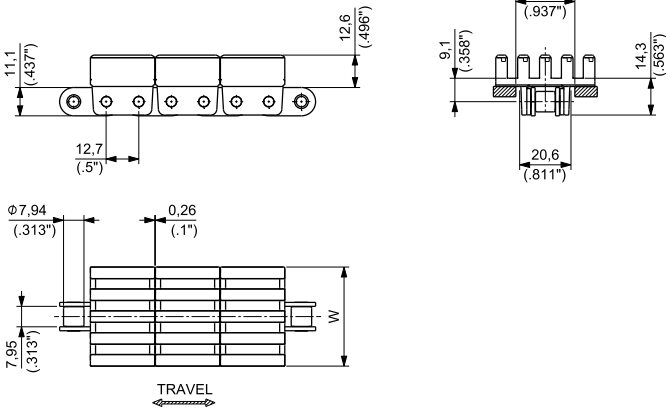

Materials  
see page 12



Combs  
see pages 80



Sprockets  
see page 153



Applications  
see page 20

Flight	MATERIALS		ITEM DESCRIPTION	PART NUMBER	CONNECTING LINK PART NUMBER	WIDTH W		WORKING LOAD (25°C/77°F)		WEIGHT	
	Base Chain	Rubber				mm	Inch	N	lbs	kg/m	lbs/ft
SPECIAL POLIPROPYLENE <b>PP</b>	CHEMICALLY NICKEL CARBON STEEL (NC) 	THERMOPLASTIC <b>TPE</b> Hardness: 50 ShA	HF RR 845 PP NC K 38,5	HFR845PPCKMB/000	18/843-003	38,5	1.57	3500	787	0,97	0.65
			HF RR 845 PP NC K 55,5	HFR845PPCKCC/000		55,5	2.11	3500	787	1,09	0.73



Standard packaging:  
Rolls of 3,048 m (10 feet)



## TRANSFER COMBS

Combs are supplied with slot covers but without fastening screws.  
 One fastening screw is required for each comb.  
 It can be ordered using P/N 16300020.



### MATERIALS

COMBS: **DG** ACETAL RESIN

SCREWS\*: **SS** STAINLESS STEEL

\*Screws are not included in the combs.

COMB FOR K 55,5 CHAIN

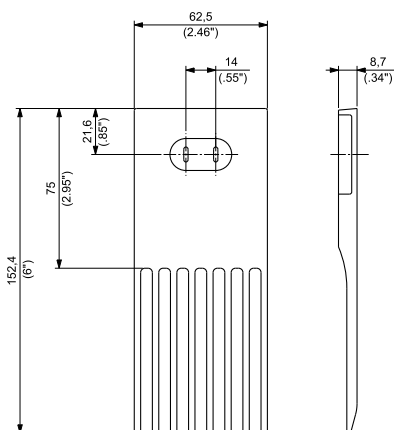

PART NUMBER **TC1600-01**

COMB FOR K 38,5 CHAIN

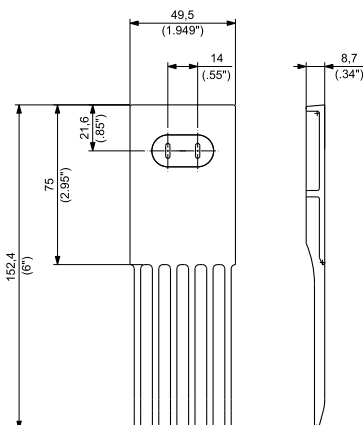

PART NUMBER **TC1600-03**

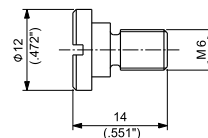

PART NUMBER **16300020**

## PLASTIC FLIGHTS

3/4" PITCH ROLLER CHAIN (ASA 60)

THICKNESS 4 mm (0.157")

HINGE 34,1 mm (1.343")

POWERED BY BASE ROLLER CHAIN MADE BY REGINA IN ITALY

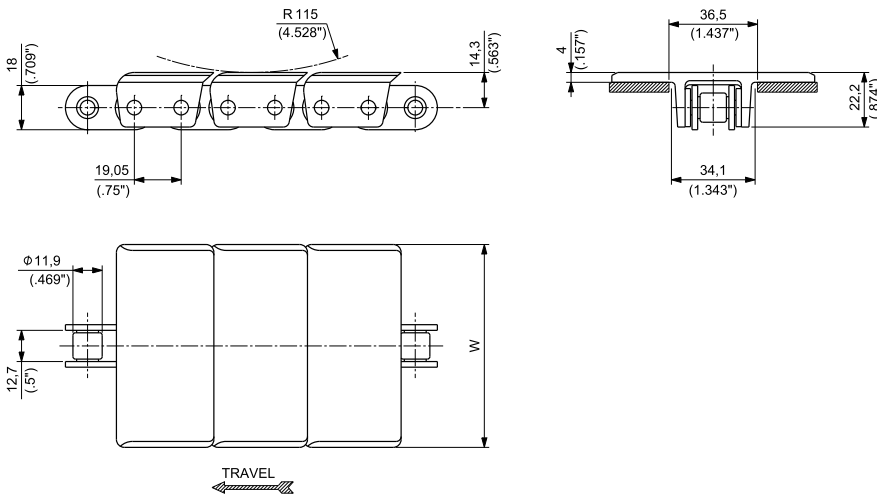
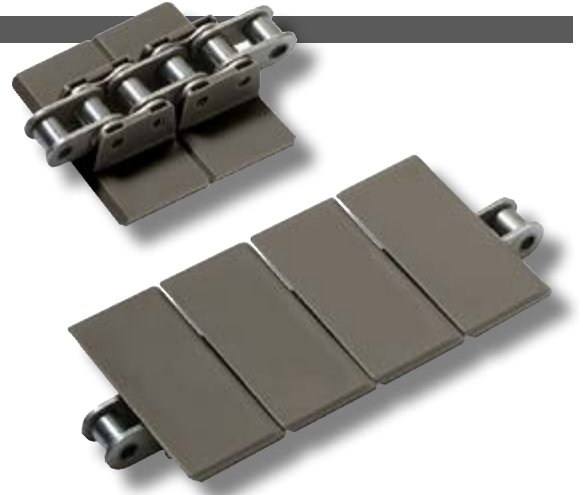

Materials see page 12



Sprockets see page 154



Applications see page 20

MATERIALS		ITEM DESCRIPTION	PART NUMBER	CONNECTING LINK PART NUMBER	WIDTH W		WORKING LOAD (25°C/77°F)		WEIGHT	
Flight	Base Chain				mm	inch	N	lbs	kg/m	lbs/ft
ULTRA PERFORMANCE HOMOPOLYMER DELRIN® <b>UP</b>	CARBON STEEL	UP 863 K 3 1/4	UP863KD/000	18/0863	82,6	3.25	5000	1124	2,21	1.48
		UP 863 K 4 1/2	UP863KG/000		114,3	4.50	5000	1124	2,38	1.60
		UP 863 K 6	UP863KH/000		152,4	6.00	5000	1124	2,58	1.73
	STAINLESS STEEL	UP 863 K 7 1/2	UP863KL/000		190,5	7.50	5000	1124	2,78	1.87
		UP 863 SS K 3 1/4	UP863SKD/000		82,6	3.25	4000	899	2,16	1.45
		UP 863 SS K 4 1/2	UP863SKG/000		114,3	4.50	4000	899	2,33	1.57
		UP 863 SS K 6	UP863SKH/000	18/SS863AB	152,4	6.00	4000	899	2,53	1.70
		UP 863 SS K 7 1/2	UP863SKL/000		190,5	7.50	4000	899	2,73	1.84



Standard packaging:  
Rolls of 3,048 m (10 feet)

**TAB**  
**PLASTIC FLIGHTS**  
**½" PITCH ROLLER CHAIN (ASA 40 SIDEBOW)**  
**THICKNESS 3.2 mm (0.126")**  
**HINGE 20 mm (0.787")**

POWERED  
 BY BASE ROLLER  
 CHAIN MADE  
 BY REGINA  
 IN ITALY

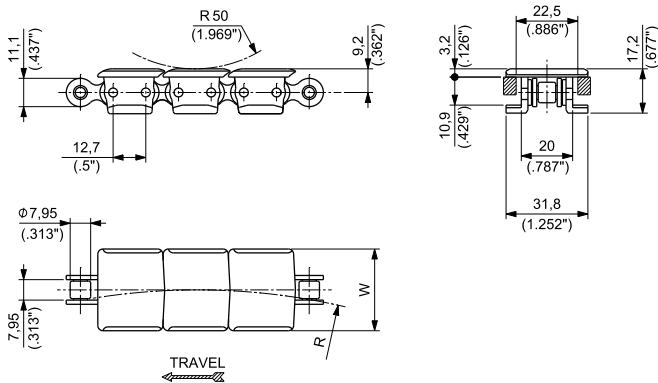
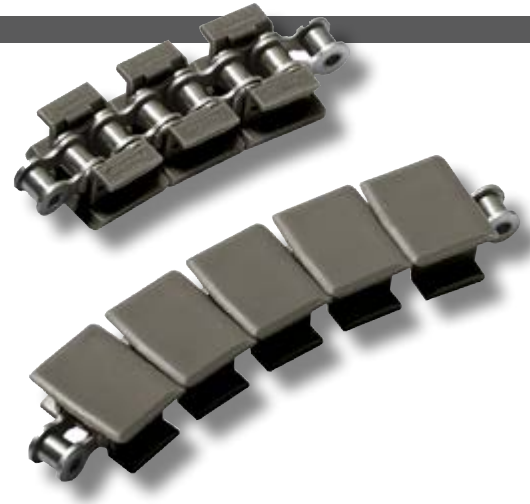

FliteTop



Materials  
 see page 12



Sprockets  
 see pages 152



Corner tracks  
 see page 322



Applications  
 see page 20

MATERIALS		ITEM DESCRIPTION	PART NUMBER	CONNECTING LINK PART NUMBER	WIDTH W		SIDEFLEXING RADIUS R		WORKING LOAD (25°C/77°F)		WEIGHT	
Flight	Base Chain				mm	inch	mm	inch	N	lbs	kg/m	lbs/ft
ULTRA PERFORMANCE HOMOPOLYMER DELRIN® <b>UP</b>	CARBON STEEL 	UP 1843T K 1 ¼	UP1843KPA/000	18/1843	31,8	1.25	254	10	2600	584	0,80	0.54
	STAINLESS STEEL 	UP 1843T SS K 1 ¼	UP1843SKPA/000	18/SS1843	31,8	1.25	254	10	2000	450	0,82	0.55
ABRASION RESISTANT POLYAMIDE* <b>AR</b>	CARBON STEEL 	AR 1843T K 1 ¼	AR1843KPA/000	18/1843	31,8	1.25	254	10	2600	584	0,80	0.54

\*Actual width is larger than the nominal width.



Standard packaging:  
 Rolls of 3,048 m (10 feet)

**TAB**  
**PLASTIC FLIGHTS**  
**3/4" PITCH ROLLER CHAIN (ASA 60 SIDEBOW)**  
**BIDIRECTIONAL**  
**THICKNESS 4 mm (0.157")**  
**HINGE 32,1 mm (1.264")**

POWERED  
 BY BASE ROLLER  
 CHAIN MADE  
 BY REGINA  
 IN ITALY

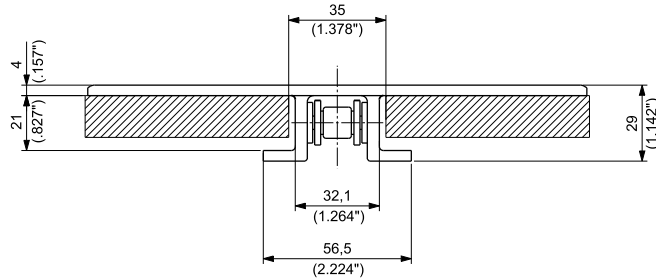
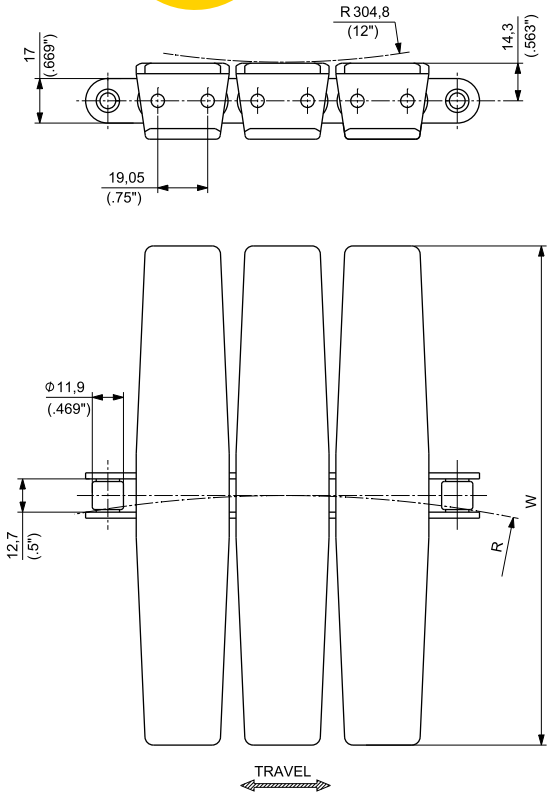
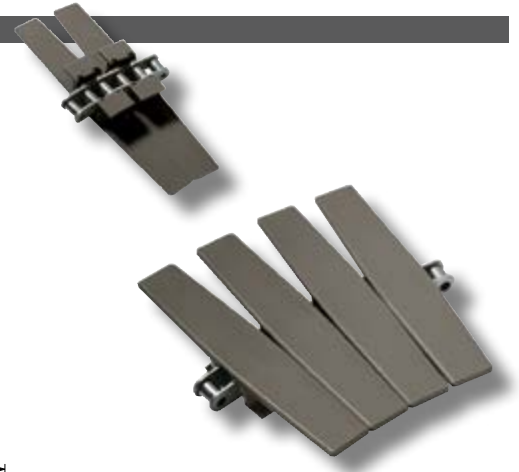

Materials  
 see page 12



Sprockets  
 see pages 154



Corner tracks  
 see page 322



Applications  
 see page 20

MATERIALS		ITEM DESCRIPTION	PART NUMBER	CONNECTING LINK PART NUMBER	WIDTH W		SIDEFLEXING RADIUS R		WORKING LOAD (25°C/77°F)		WEIGHT		
Flight	Base Chain				mm	inch	mm	inch	N	lbs	kg/m	lbs/ft	
ULTRA PERFORMANCE HOMOPOLYMER DELRIN® <b>UP</b>	CARBON STEEL	UP 1873T K 3 1/4	UP1873KD/000	18/0873	82,6	3.25	355,6	14	4500	1,012	2,31	1.55	
		UP 1873T K 4 1/2	UP1873KG/000		114,3	4.50	355,6	14	4500	1,012	2,39	1.60	
		UP 1873T K 6	UP1873KH/000		152,4	6.00	457,2	18	4500	1,012	2,57	1.73	
		UP 1873T K 7 1/2	UP1873KL/000		190,5	7.50	457,2	18	4500	1,012	2,86	1.92	
		UP 1873T K 10	UP1873KM/000		254,0	10.00	457,2	18	4500	1,012	2,99	2.01	
	UP 1873T K 12	UP1873KN/000	304,8		12.00	609,6	24	4500	1,012	3,15	2.12		
	STAINLESS STEEL	UP 1873T SS K 3 1/4	UP1873SKD/000		18/SS873AB	82,6	3.25	355,6	14	3500	787	2,25	1.51
		UP 1873T SS K 4 1/2	UP1873SKG/000			114,3	4.50	355,6	14	3500	787	2,33	1.57
		UP 1873T SS K 6	UP1873SKH/000			152,4	6.00	457,2	18	3500	787	2,52	1.69
		UP 1873T SS K 7 1/2	UP1873SKL/000			190,5	7.50	457,2	18	3500	787	2,80	1.88
UP 1873T SS K 10		UP1873SKM/000	254,0	10.00		457,2	18	3500	787	2,94	1.97		
UP 1873T SS K 12	UP1873SKN/000	304,8	12.00	609,6	24	3500	787	3,09	2.08				



Standard packaging:  
 Rolls of 3,048 m (10 feet)



## PLASTIC FLIGHTS

1" PITCH ROLLER CHAIN (ASA 80 SIDEBOW) WITH INTEGRATED BEARINGS

THICKNESS 4,8 mm (0.189")

HINGE 41,3 mm (1.626")

**NEW**

POWERED BY BASE ROLLER CHAIN MADE BY REGINA IN ITALY

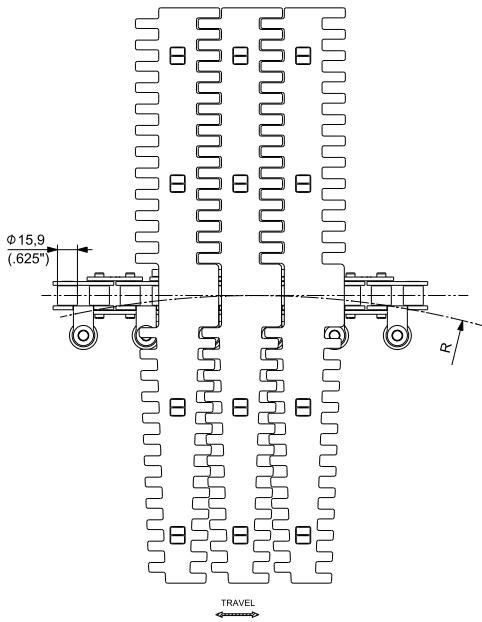
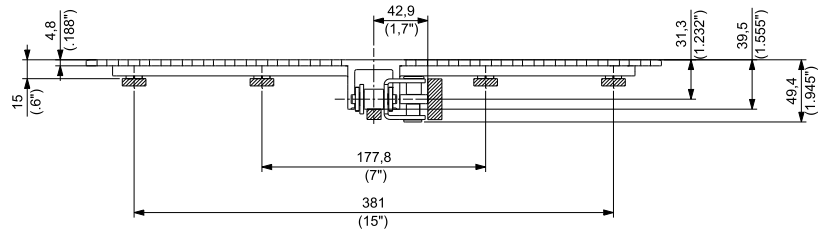
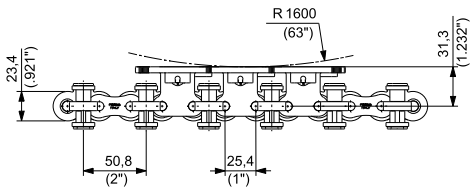

Materials see page 12



Sprockets see page 155



Applications see page 20

MATERIALS		ITEM DESCRIPTION	PART NUMBER	CONNECTING LINK PART NUMBER	WIDTH W		SIDEFLEXING RADIUS R		WORKING LOAD (25°C/77°F)		WEIGHT	
Flight	Base Chain				mm	inch	mm	inch	N	lbs	kg/m	lbs/ft
ULTRA PERFORMANCE HOMOPOLYMER DELRIN®	CARBON STEEL	UP 1883 K 18	UP1883KZB/000	18/80SB-007	457,2	18	650	25.59	6500	1,461	7,30	4.91
<b>UP</b>												



Standard packaging: Rolls of 1,524 m (5 feet)



**RUBBERIZED TOP PLASTIC FLIGHTS**  
**1" PITCH ROLLER CHAIN (ASA 80 SIDEBOW) WITH INTEGRATED BEARINGS**  
**THICKNESS 4,8 mm (0.189")**  
**HINGE 41,3 mm (1.626")**

**NEW**

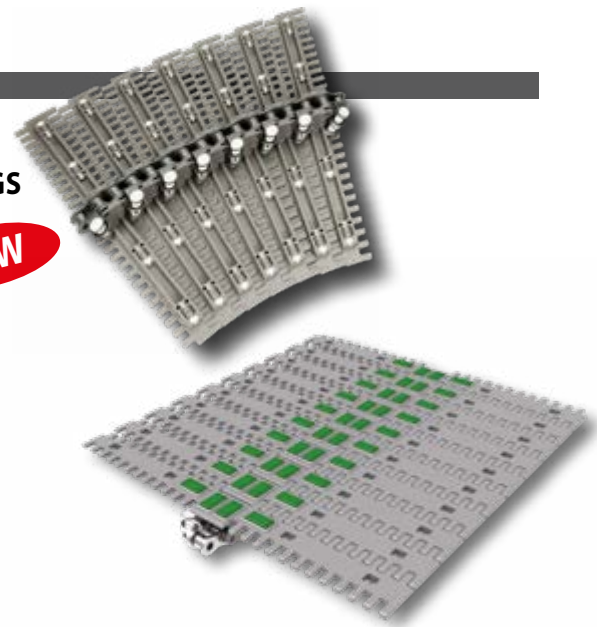

POWERED BY BASE ROLLER CHAIN MADE BY REGINA IN ITALY

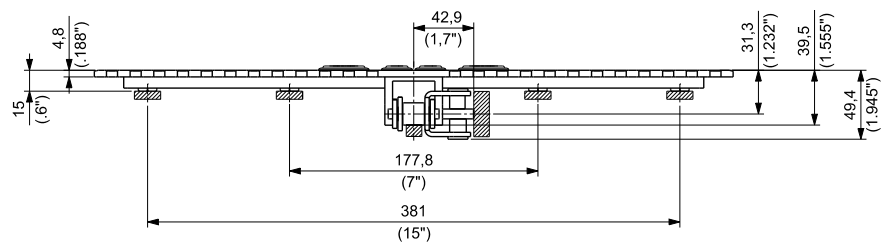
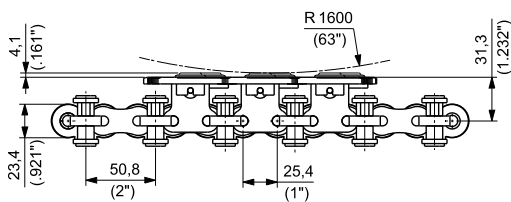

4- RUBBER PAD VERSION

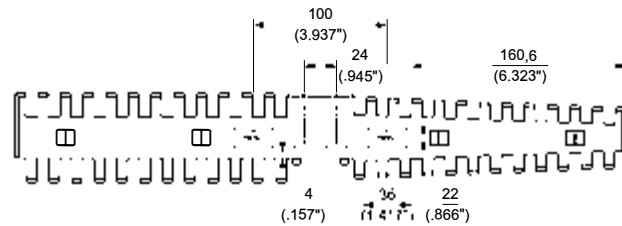

8- RUBBER PAD VERSION

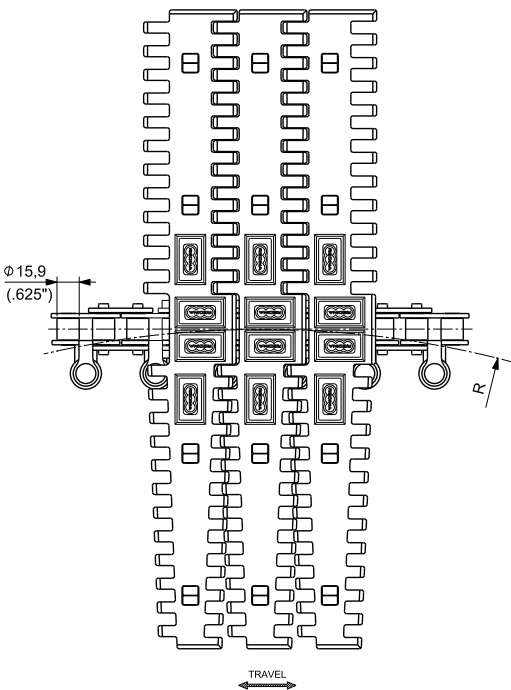

Materials see page 12



Sprockets see page 155



Applications see page 20

Flight	MATERIALS		ITEM DESCRIPTION	PART NUMBER	CONNECTING LINK	WIDTH W		SIDEFLEXING RADIUS R		WORKING LOAD (25°C/77°F)		WEIGHT	
	Base Chain	Rubber				mm	inch	mm	inch	N	lbs	kg/m	lbs/ft
UP	ULTRA PERFORMANCE HOMOPOLYMER DELRIN® CARBON STEEL	THERMOPLASTIC TPE	HFX 1883 UP K 18 (4-Rubber pad version)	HFX1883UPKZB/000	18/80SB-007	457,2	18	650	25.59	6500	1,461	7,54	5.08
		Hardness: 70 ShA	HFX 1883 UP K 18 (8-Rubber pad version)	HFX1883UPKZB/001	18/80SB-007	457,2	18	650	25.59	6500	1,461	7,75	5.22



Standard packaging: Rolls of 1,524 m (5 feet)



PERFORMANCE IN MOTION

# ***FliteTop***<sup>®</sup> Gripper Chains

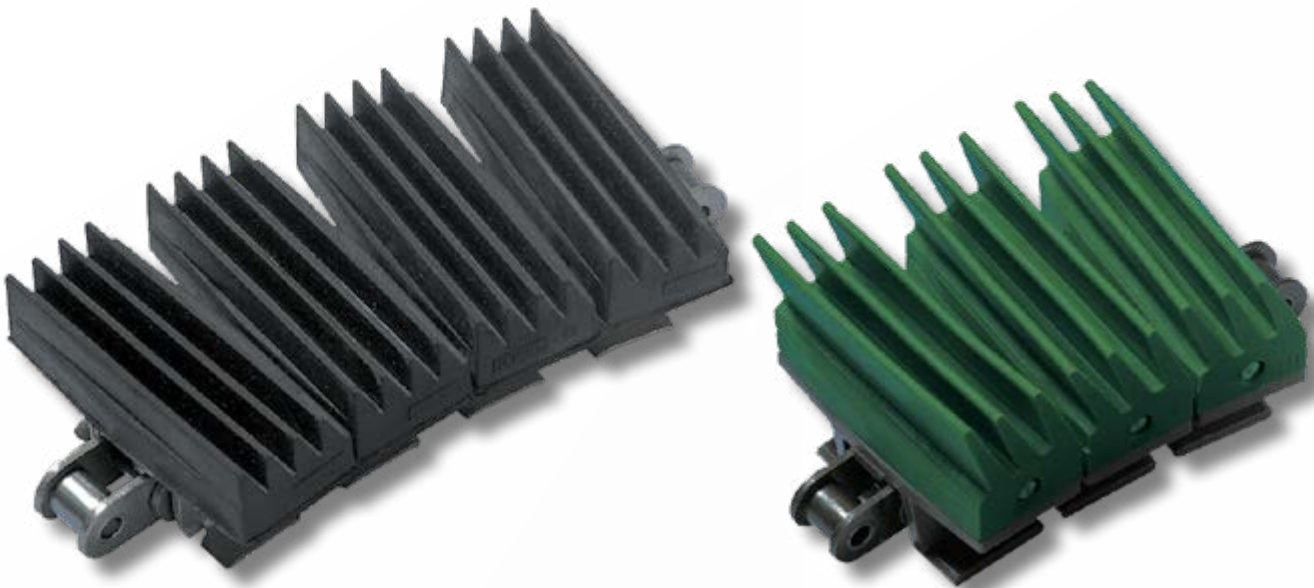

## INDUSTRIES AND APPLICATIONS

### GRIPPER CHAINS

Suitable for handling plastic and glass bottles, aluminum and steel cans through an elevated path.

#### INDUSTRIES

- Bottling and canning
- Glass manufacturing
- Container manufacturing
- Food filling

#### APPLICATIONS

- Elevator
- Lowerator
- Pass through conveyors
- Rinsers



## FEATURES

- Powered by ASA 40 and ASA 60 base roller chains made by REGINA in Italy. In particular:
  - Stainless steel chain prelubricated with high performance lube suitable for the food industry (USDA H1 approved) which guarantees long-lasting effect for the chain.
  - ENDURO maintenance free chain that eliminates need for periodic lubrication.
- Wide range of rubber pads exerting an ideal and fine-tuned force on the products for each specific application.
- Reliable fixing system of gripper to the flight by knurled austenitic stainless steel pin.

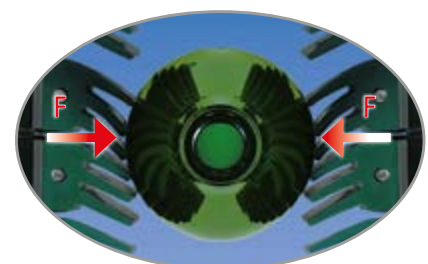

# Available with ENDURO maintenance free base chains.



- "Heavy wall" sintered bushing, impregnated with USDA H1 food approved oil
- Hard plated pin
- Galvanically coated plates and rollers for resistance to mildly aggressive environment



## BENEFITS

- DRAMATIC WEAR LIFE INCREASE COMPARED TO STANDARD CHAINS IN UN-LUBRICATED CONDITIONS
- ELIMINATE NEED FOR PERIODIC LUBRICATION
- NO PRODUCT OR EQUIPMENT CONTAMINATION
- RESISTANCE TO CORROSION IN MILDLY AGGRESSIVE ENVIRONMENT
- SAVINGS IN LUBRICATION AND MAINTENANCE COSTS



## Comparative wear test - 16B-1 chains with sintered bushings.

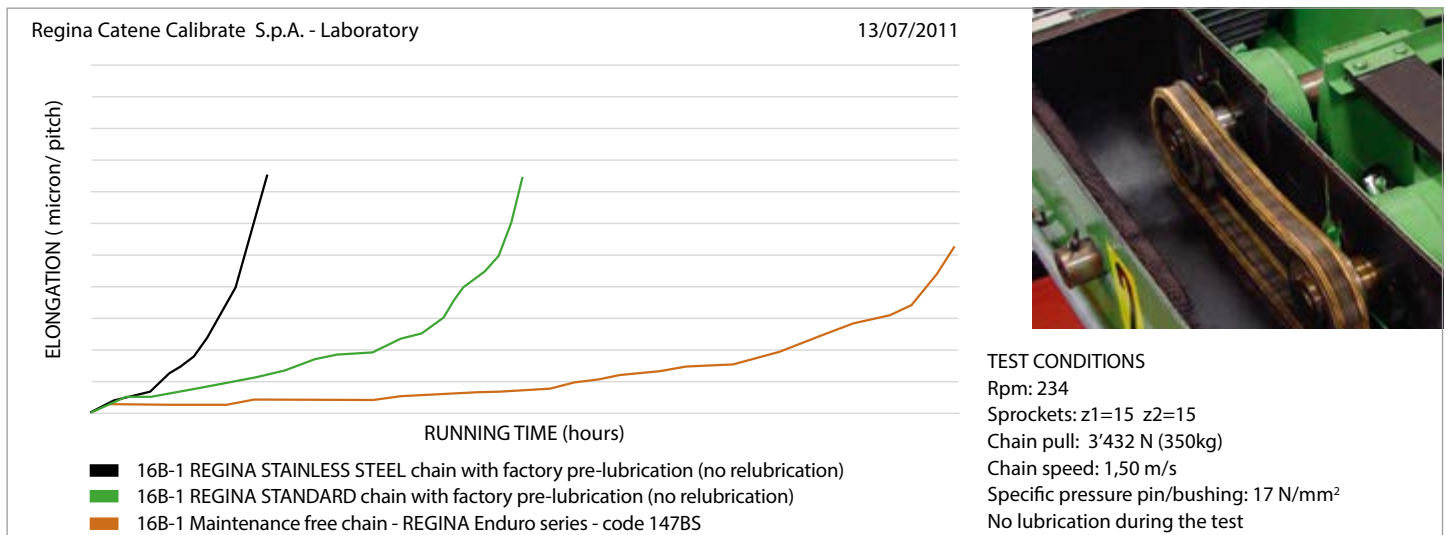



## TAB STEEL FLIGHTS

3/4" PITCH ROLLER CHAIN (ASA 60 SIDEBOW)

SHORT FINGERS RUBBER PAD

THICKNESS 3 mm (0.118")

HINGE 31,8 mm (1.252")

POWERED  
BY BASE ROLLER  
CHAIN MADE  
BY REGINA  
IN ITALY

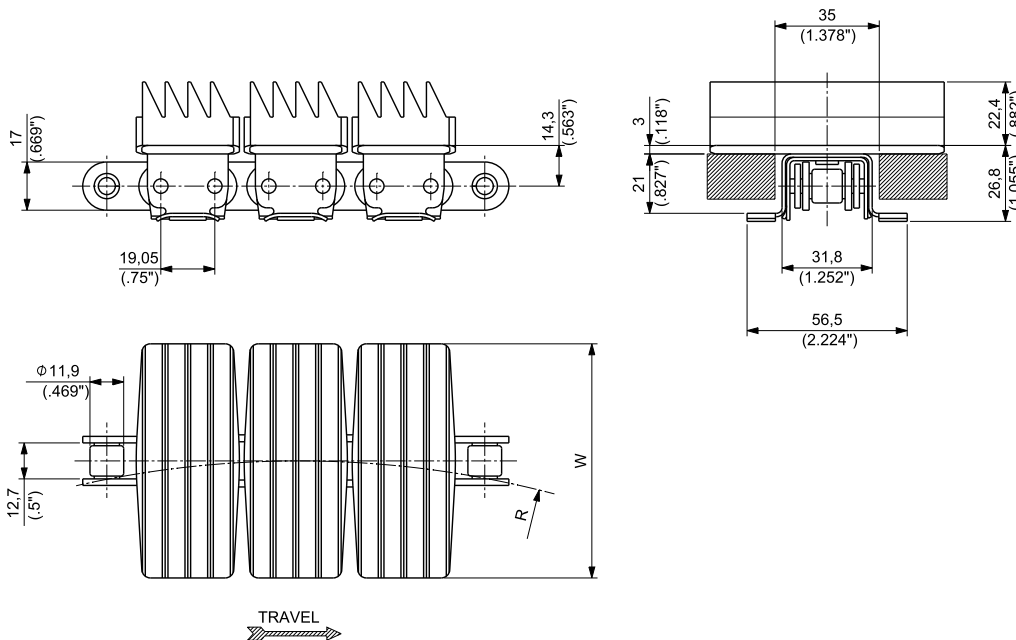

Materials  
see page 12



Sprockets  
see page 154



Corner tracks  
see page 322



Applications  
see page 20

MATERIALS			ITEM DESCRIPTION	PART NUMBER	CONNECTING LINK PART NUMBER	WIDTH W		SIDEFLEXING RADIUS R		WORKING LOAD (25°C/77°F)		WEIGHT	
Flight	Base Chain	Rubber				mm	inch	mm	inch	N	lbs	kg/m	lbs/ft
CARBON STEEL s	CARBON STEEL	EPDM	GV 1874T K 3 1/4	GV1874KD/010	18/0873	82,6	3.25	381	15	4500	1,012	5,65	3.79
		Hardness: 60 ShA	GV 1874T K 4 1/2	GV1874KG/010		114,3	4.50	381	15	4500	1,012	6,71	4.51
STAINLESS STEEL ss	STAINLESS STEEL	EPDM	GV 1874T SS K 3 1/4	GV1874SKD/010	18/SS873AB	82,6	3.25	381	15	3500	787	5,57	3.74
		Hardness: 60 ShA	GV 1874T SS K 4 1/2	GV1874SKG/010		114,3	4.50	381	15	3500	787	6,63	4.46



Standard packaging:  
Rolls of 3,048 m (10 feet)

**TAB STEEL FLIGHTS**  
**3/4" PITCH ROLLER CHAIN (ASA 60 SIDEBOW)**  
**LONG FINGERS RUBBER PAD**  
**THICKNESS 3 mm (0.118")**  
**HINGE 31,8 mm (1.252")**

POWERED  
BY BASE ROLLER  
CHAIN MADE  
BY REGINA  
IN ITALY

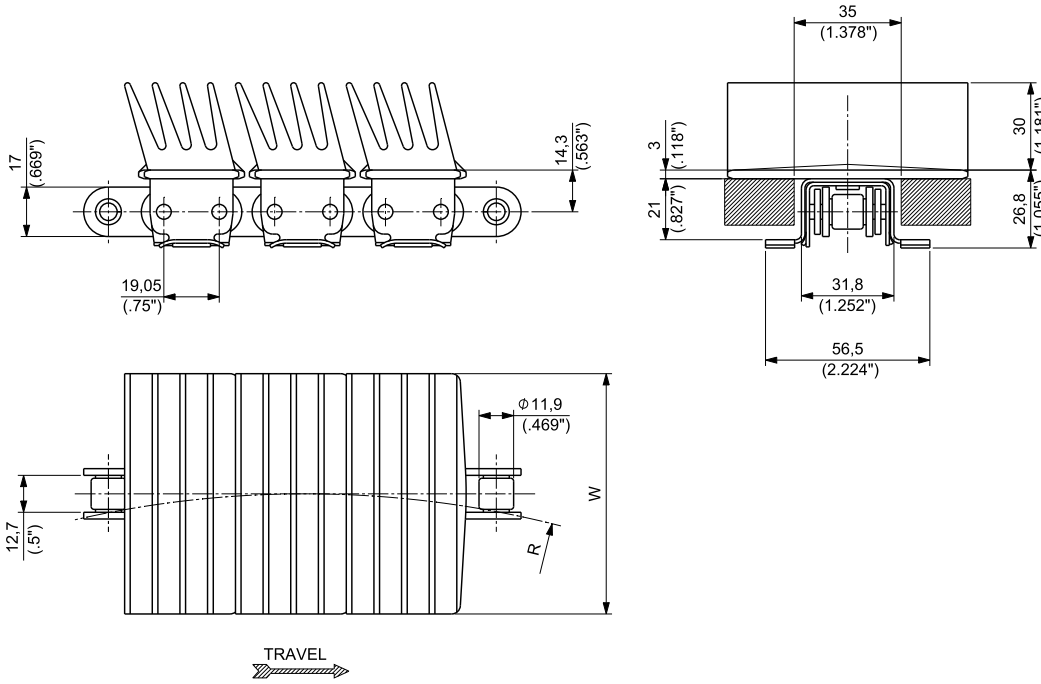

Materials  
see page 12



Sprockets  
see page 154



Corner tracks  
see page 322



Applications  
see page 20

MATERIALS			ITEM DESCRIPTION	PART NUMBER	CONNECTING LINK PART NUMBER	WIDTH W		SIDEFLEXING RADIUS R		WORKING LOAD (25°C/77°F)		WEIGHT	
Flight	Base Chain	Rubber				mm	inch	mm	inch	N	lbs	kg/m	lbs/ft
CARBON STEEL s	CARBON STEEL S	EPDM EPDM Hardness: 60 ShA	EV 1874T K 3 1/4	EV1874KD/010	18/0873	82,6	3.25	381	15	4500	1,012	5,67	3.81
STAINLESS STEEL SS	STAINLESS STEEL SS	EPDM EPDM Hardness: 60 ShA	EV 1874T SS K 3 1/4	EV1874SKD/010	18/SS873AB	82,6	3.25	381	15	3500	787	5,60	3.76



Standard packaging:  
Rolls of 3,048 m (10 feet)



**TAB PLASTIC FLIGHTS**  
**3/4" PITCH ROLLER CHAIN (ASA 60 SIDEBOW)**  
**SHORT FINGERS RUBBER PAD**  
**THICKNESS 4 mm (0.157")**  
**HINGE 32,1 mm (1.264")**

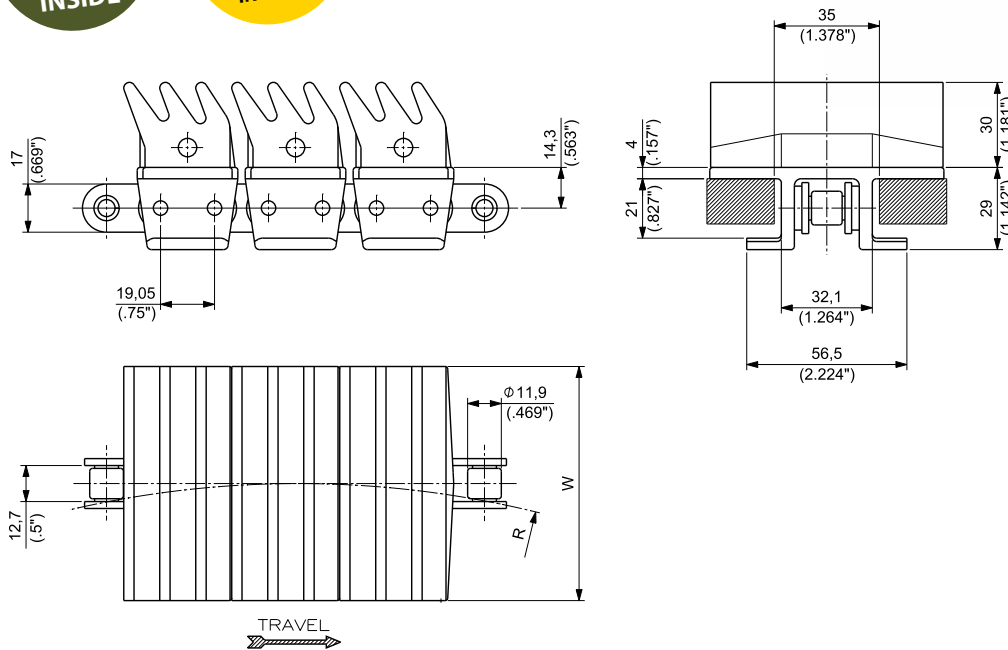
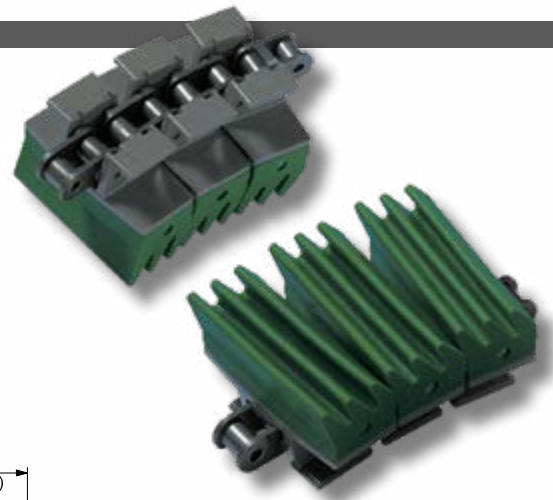

Materials see page 12



Sprockets see page 154



Corner tracks see page 322



Applications see page 20

Flight	MATERIALS		ITEM DESCRIPTION	PART NUMBER	CONNECTING LINK PART NUMBER	WIDTH W		SIDEFLEXING RADIUS R		WORKINGLOAD (25°C/77°F)		WEIGHT	
	Base chain	Rubber				mm	inch	mm	inch	N	lbs	kg/m	lbs/ft
	CARBON STEEL 		GW 1873T UP K 3 1/4	GW1873KD/000	18/0873	82,6	3.25	355,6	14	4500	1012	4,54	3.05
ULTRA PERFORMANCE HOMOPOLYMER DELRIN® <b>UP</b>	STAINLESS STEEL 	THERMOPLASTIC <b>TPE</b> Hardness: 50 ShA	GW 1873T UP SS K 3 1/4	GW1873SKD/000	18/SS873AB	82,6	3.25	355,6	14	3500	787	4,49	3.02
	MAINTENANCE FREE CARBON STEEL 		GW 1873T UP BS K 3 1/4	GW1873UPBKD/000	18/873BS	82,6	3.25	355,6	14	3500	787	4,28	2.87
	CARBON STEEL 		GW 1873T D2K K 3 1/4	GW1873D2KKD/000	18/0873	82,6	3.25	355,6	14	4500	1012	4,54	3.05
SPECIAL DELRIN® REINFORCED WITH KEVLAR® <b>DK2</b>	STAINLESS STEEL 	THERMOPLASTIC <b>TPE</b> Hardness: 50 ShA	GW 1873T D2K SS K 3 1/4	GW1873D2KSKD/000	18/SS873AB	82,6	3.25	355,6	14	3500	787	4,49	3.02
	MAINTENANCE FREE CARBON STEEL 		GW 1873T D2K BS K 3 1/4	GW1873D2KBKD/000	18/873BS	82,6	3.25	355,6	14	3500	787	4,28	2.87



Standard packaging:  
Rolls of 3,048 m (10 feet)

## TAB PLASTIC FLIGHTS

3/4" PITCH ROLLER CHAIN (ASA 60 SIDEBOW)

LONG FINGERS RUBBER PAD

THICKNESS 4 mm (0.157")

HINGE 32,1 mm (1.264")

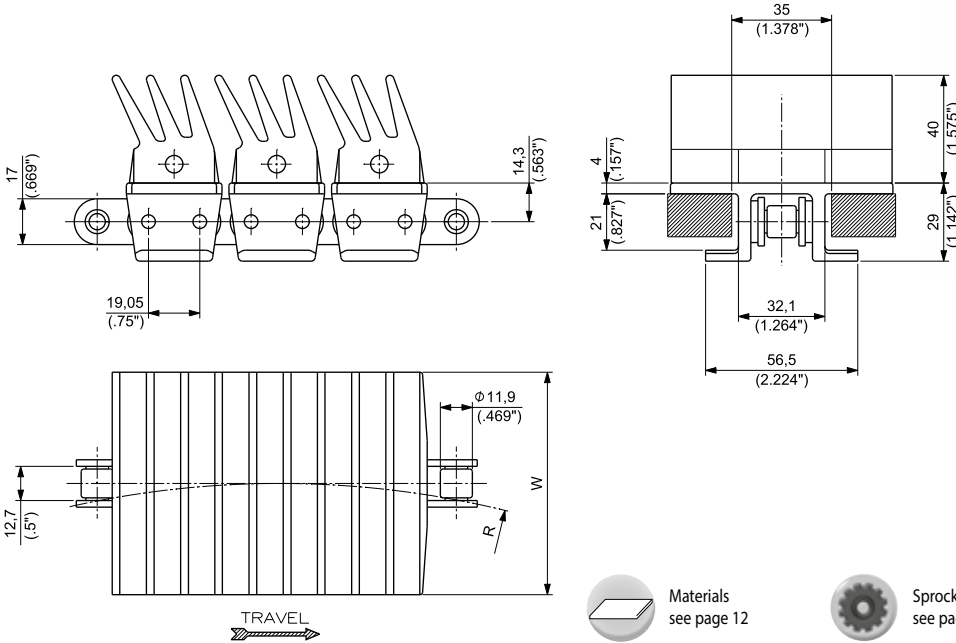
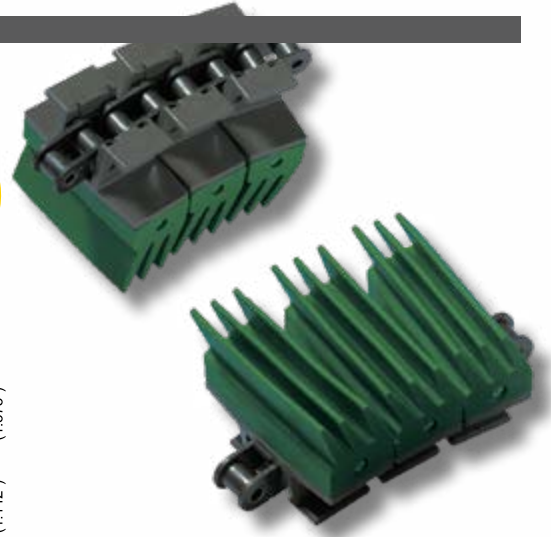

Materials see page 12



Sprockets see page 154



Corner tracks see page 322



Applications see page 20

MATERIALS			ITEM DESCRIPTION	PART NUMBER	CONNECTING LINK PART NUMBER	WIDTH W	SIDEFLEXING RADIUS R	WORKING LOAD (25°C/77°F)	WEIGHT
Flight	Base chain	Rubber				mm inch	mm inch	N lbs	kg/m lbs/ft
CARBON STEEL			EW 1873T UP K 3 1/4	EW1873KD/000	18/0873	82,6 3.25	355,6 14.00	4500 1012	4,68 3.14
			EW 1873T UP K 4 1/2	EW1873UPKG/000		114,3 4.50	355,6 14.00	4500 1012	5,72 3.84
STAINLESS STEEL		THERMOPLASTIC TPE Hardness: 50 ShA	EW 1873T UP SS K 3 1/4	EW1873SKD/000	18/SS873AB	82,6 3.25	355,6 14.00	3500 787	4,62 3.11
			EW 1873T UP SS K 4 1/2	EW1873UPSKG/000		114,3 4.50	355,6 14.00	3500 787	5,67 3.81
ULTRA PERFORMANCE HOMOPOLYMER DELRIN® UP			EW 1873T UP BS K 3 1/4	EW1873UPBKD/000	18/873BS	82,6 3.25	355,6 14.00	3500 787	4,38 2.95
			EW 1873T UP BS K 4 1/2	EW1873UPBKG/000		114,3 4.50	355,6 14.00	3500 787	5,32 3.57
STAINLESS STEEL		HEAT STABILIZED THERMOPLASTIC HS Hardness: 45 ShA	EW 1873T UP HS SS K 3 1/4	EW1873HSSKD/003	18/SS873AB	82,6 3.25	355,6 14.00	3500 787	4,62 3.11
CARBON STEEL			EW 1873T D2K K 3 1/4	EW1873D2KKD/000	18/0873	82,6 3.25	355,6 14.00	4500 1012	4,68 3.14
			EW 1873T D2K K 4 1/2	EW1873D2KKG/000		114,3 4.50	355,6 14.00	4500 1012	5,72 3.84
STAINLESS STEEL		THERMOPLASTIC TPE Hardness: 50 ShA	EW 1873T D2K SS K 3 1/4	EW1873D2KSKD/000	18/SS873AB	82,6 3.25	355,6 14.00	3500 787	4,62 3.11
			EW 1873T D2K SS K 4 1/2	EW1873D2KSKG/000		114,3 4.50	355,6 14.00	3500 787	5,67 3.81
SPECIAL DELRIN® REINFORCED WITH KEVLAR® DK2			EW 1873T D2K BS K 3 1/4	EW1873D2KBKD/000	18/873BS	82,6 3.25	355,6 14.00	3500 787	4,38 2.95
			EW 1873T D2K BS K 4 1/2	EW1873D2KBKG/000		114,3 4.50	355,6 14.00	3500 787	5,32 3.57
STAINLESS STEEL		HEAT STABILIZED THERMOPLASTIC HS Hardness: 45 ShA	EW 1873T D2K HS SS K 3 1/4	EW1873HSSKD/002	18/SS873AB	82,6 3.25	355,6 14.00	3500 787	4,62 3.11

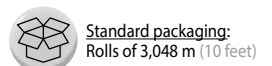

## TAB PLASTIC FLIGHTS

3/4" PITCH ROLLER CHAIN (ASA 60 SIDEBOW)

D-SHAPE RUBBER PAD

THICKNESS 4 mm (0.157")

HINGE 32,1 mm (1.264")

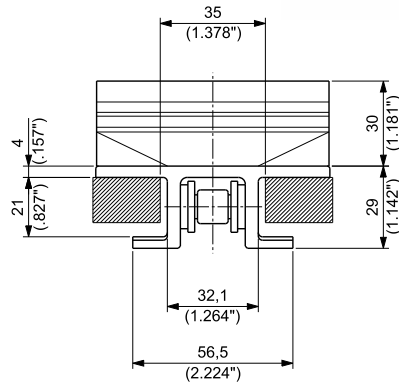
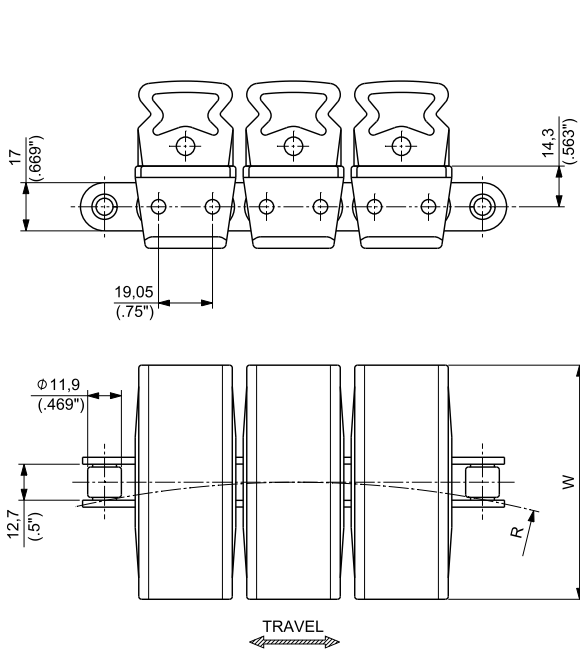
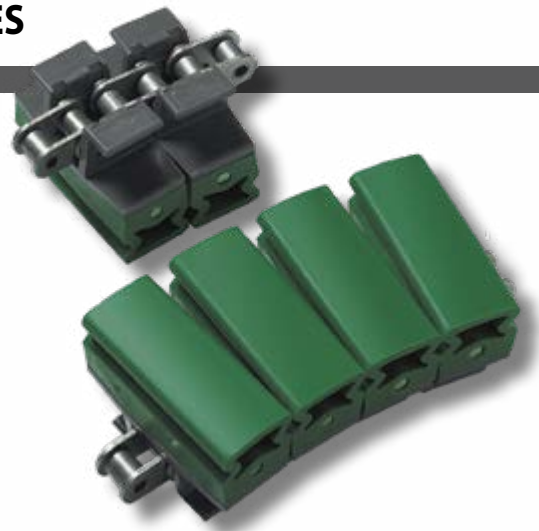

FliteTop



Materials see page 12



Sprockets see page 154



Corner tracks see page 322



Applications see page 20

Flight	MATERIALS		ITEM DESCRIPTION	PART NUMBER	CONNECTING LINK PART NUMBER	WIDTH		SIDEFLEXING RADIUS		WORKING LOAD (25°C/77°F)		WEIGHT	
	Base chain	Rubber				mm	inch	mm <sup>R</sup>	inch	N	lbs	kg/m	lbs/ft
	CARBON STEEL		GD 1873T UP K 3 1/4	GD1873UPKD/000	18/0873	82,6	3.25	355,6	14	4500	1012	4,29	2.88
ULTRA PERFORMANCE HOMOPOLYMER DELRIN® <b>UP</b>	STAINLESS STEEL	THERMOPLASTIC TPE Hardness: 50 Sha	GD 1873T UP SS K 3 1/4	GD1873UPSKD/000	18/SS873AB	82,6	3.25	355,6	14	3500	787	4,24	2.85
	MAINTENANCE FREE CARBON STEEL		GD 1873T UP BS K 3 1/4	GD1873UPBKD/000	18/873BS	82,6	3.25	355,6	14	3500	787	4,07	2.73
	CARBON STEEL		GD 1873T D2K K 3 1/4	GD1873D2KKD/000	18/0873	82,6	3.25	355,6	14	4500	1012	4,29	2.88
SPECIAL DELRIN® REINFORCED WITH KEVLAR® <b>DK2</b>	STAINLESS STEEL	THERMOPLASTIC TPE Hardness: 50 Sha	GD 1873T D2K SS K 3 1/4	GD1873D2KSKD/000	18/SS873AB	82,6	3.25	355,6	14	3500	787	4,24	2.85
	MAINTENANCE FREE CARBON STEEL		GD 1873T D2K BS K 3 1/4	GD1873D2KBKD/000	18/873BS	82,6	3.25	355,6	14	3500	787	4,07	2.73



Standard packaging:  
Rolls of 3,048 m (10 feet)

## TAB PLASTIC FLIGHTS

3/4" PITCH ROLLER CHAIN (ASA 60 SIDEBOW)

U-SHAPE RUBBER PAD

THICKNESS 4 mm (0.157")

HINGE 32,1 mm (1.264")

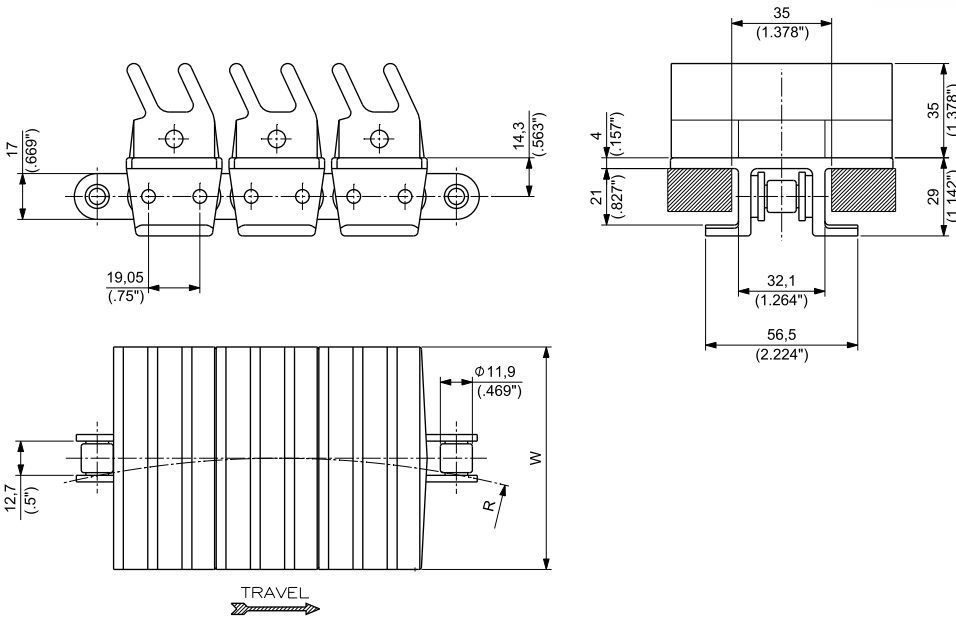

Materials  
see page 12



Sprockets  
see page 154



Corner tracks  
see page 322



Applications  
see page 20

Flight	MATERIALS		ITEM DESCRIPTION	PART NUMBER	CONNECTING LINK PART NUMBER	WIDTH W		SIDEFLEXING RADIUS R		WORKING LOAD (25°C/77°F)		WEIGHT	
	Base chain	Rubber				mm	inch	mm	inch	N	lbs	kg/m	lbs/ft
ULTRA PERFORMANCE HOMOPOLYMER DELRIN® UP	CARBON STEEL	THERMOPLASTIC TPE	GU 1873T UP K 3 1/4	GU1873UPKD/000	18/0873	82,6	3.25	355,6	14	4500	1012	4,41	2.96
	GU 1873T UP K 4 1/2		GU1873UPKG/000	114,3		4.50	355,6	14	4500	1012	5,35	3.59	
	STAINLESS STEEL	Hardness: 50 ShA	GU 1873T UP SS K 3 1/4	GU1873UPSKD/000	18/SS873AB	82,6	3.25	355,6	14	3500	787	4,35	2.93
	GU 1873T UP SS K 4 1/2		GU1873UPSKG/000	114,3		4.50	355,6	14	3500	787	5,29	3.56	
SPECIAL DELRIN® REINFORCED WITH KEVLAR®	CARBON STEEL	THERMOPLASTIC TPE	GU 1873T D2K K 3 1/4	GU1873D2KKD/000	18/0873	82,6	3.25	355,6	14	4500	1012	4,41	2.96
	GU 1873T D2K K 4 1/2		GU1873D2KKG/000	114,3		4.50	355,6	14	4500	1012	5,35	3.59	
	STAINLESS STEEL	Hardness: 50 ShA	GU 1873T D2K SS K 3 1/4	GU1873D2KSKD/000	18/SS873AB	82,6	3.25	355,6	14	3500	787	4,35	2.93
	GU 1873T D2K SS K 4 1/2		GU1873D2KSKG/000	114,3		4.50	355,6	14	3500	787	5,29	3.56	



Standard packaging:  
Rolls of 3,048 m (10 feet)

**TAB PLASTIC FLIGHTS**  
**3/4" PITCH ROLLER CHAIN (ASA 60 SIDEBOW)**  
**D-SHAPE RUBBER PAD**  
**THICKNESS 4 mm (0.157")**  
**HINGE 32,1 mm (1.264")**

**NEW**

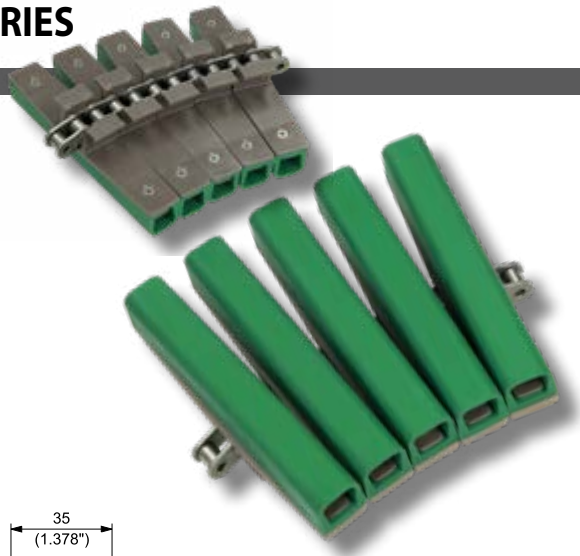

**DUPONT® KEVLAR® INSIDE**

**POWERED BY BASE ROLLER CHAIN MADE BY REGINA IN ITALY**

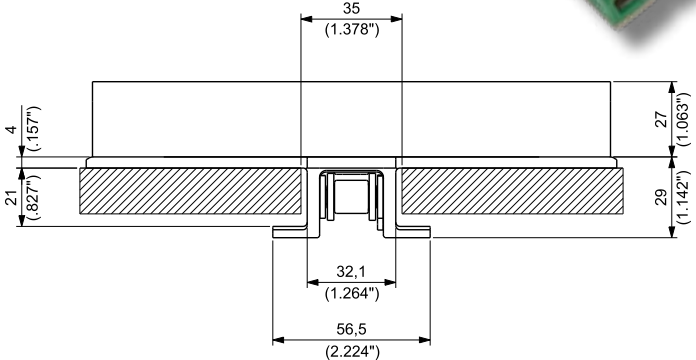
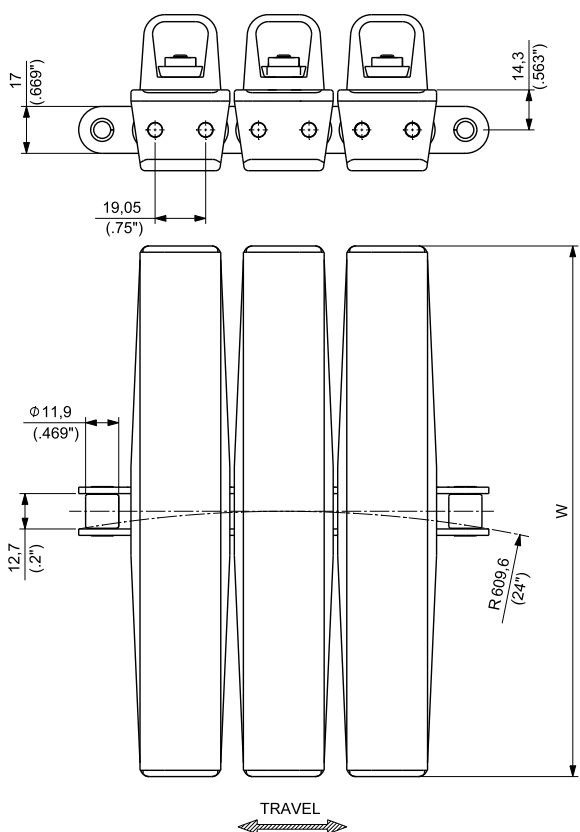

Materials see page 12      Sprockets see page 154      Applications see page 20

MATERIALS		ITEM DESCRIPTION	PART NUMBER	CONNECTING LINK PART NUMBER	WIDTH W	SIDEFLEXING RADIUS	WORKING LOAD (25°C/77°F)	WEIGHT				
Flight	Base chain	Rubber			mm	inch	N	lbs	kg/m lbs/ft			
	THERMOPLASTIC											
	<b>TPE</b>	GD 1873T UP SS K 7 1/2	GD1873UPSKL/000	18/SS873AB	190,5	7.50	609,6	24	3500	787	4,90	3.29
	ULTRA PERFORMANCE HOMOPOLYMER DELRIN®	Hardness: 50 Sha										
	<b>UP</b>											
	STAINLESS STEEL											
	<b>SS</b>											
	HEAT STABILIZED THERMOPLASTIC											
	<b>HS</b>	GD 1873T UP H SS K 7 1/2	GD1873UPHSKL/000	18/SS873AB	190,5	7.50	609,6	24	3500	787	5,26	3.53
	Hardness: 70 Sha											
	THERMOPLASTIC											
	<b>TPE</b>	GD 1873T D2K SS K 7 1/2	GD1873D2KSKL/000	18/SS873AB	190,5	7.50	609,6	24	3500	787	4,90	3.29
	SPECIAL DELRIN®	Hardness: 50 Sha										
	STAINLESS STEEL											
	<b>SS</b>											
	REINFORCED WITH KEVLAR®											
	<b>DK2</b>											
	HEAT STABILIZED THERMOPLASTIC											
	<b>HS</b>	GD 1873T D2K H SS K 7 1/2	GD1873D2KHSKL/000	18/SS873AB	190,5	7.50	609,6	24	3500	787	5,26	3.53
	Hardness: 70 Sha											

Standard packaging:  
Rolls of 3,048 m (10 feet)



## TAB PLASTIC FLIGHTS

3/4" PITCH ROLLER CHAIN (ASA 60 SIDEBOW)

"HOUSE"-SHAPED RUBBER PAD

THICKNESS 4 mm (0.157")

HINGE 32,1 mm (1.264")

**NEW**

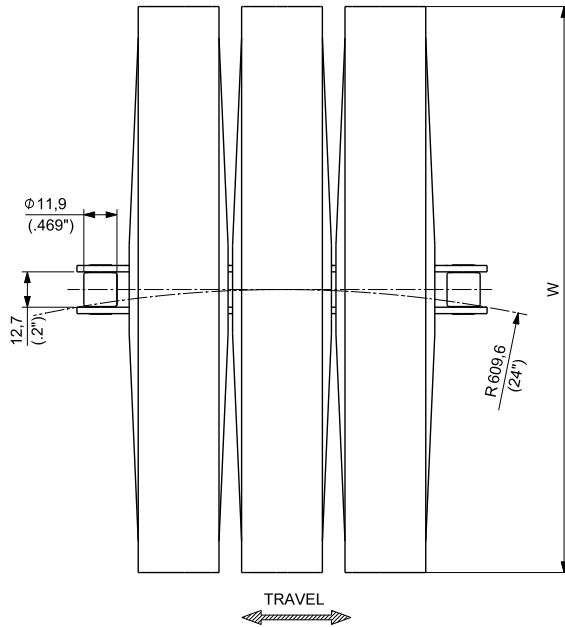
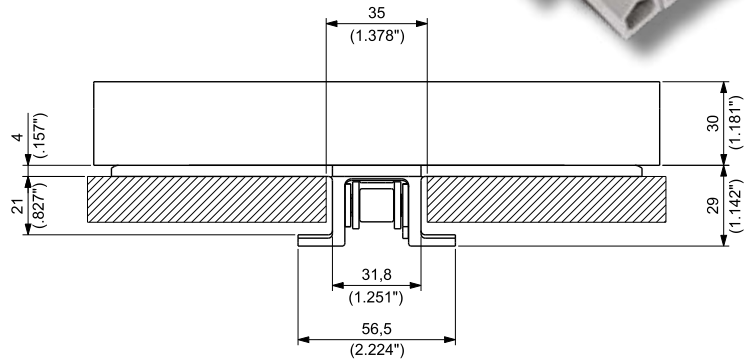
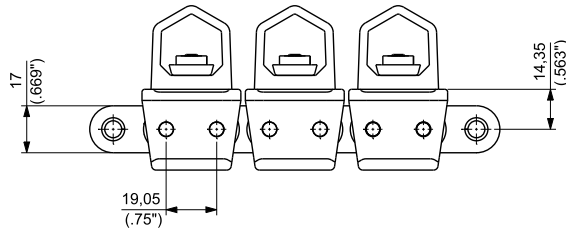

Materials see page 12



Sprockets see page 154



Applications see page 20

MATERIALS		ITEM DESCRIPTION	PART NUMBER	CONNECTING LINK PART NUMBER	WIDTH W	SIDEFLEXING RADIUS R	WORKING LOAD (25°C/77°F)	WEIGHT				
Flight	Base chain	Rubber			mm	inch	N	lbs	kg/m	lbs/ft		
ULTRA PERFORMANCE HOMOPOLYMER DELRIN® <b>UP</b>	THERMOPLASTIC <b>TPE</b>	GC 1873T UP SS K 8	GC1873UPSKV/000	18/SS873AB	203,2	8	609,6	24	3500	787	4,90	3,29
	Hardness: 50 ShA											
SPECIAL DELRIN® REINFORCED WITH KEVLAR® <b>DK2</b>	STAINLESS STEEL <b>SS</b>	GC 1873T UP H SS K 8	GC1873UPHSKV/000	18/SS873AB	203,2	8	609,6	24	3500	787	5,26	3,53
	HEAT STABILIZED THERMOPLASTIC <b>HS</b>											
SPECIAL DELRIN® REINFORCED WITH KEVLAR® <b>DK2</b>	THERMOPLASTIC <b>TPE</b>	GC 1873T D2K SS K 8	GC1873D2KSKV/000	18/SS873AB	203,2	8	609,6	24	3500	787	4,90	3,29
	Hardness: 50 ShA											
SPECIAL DELRIN® REINFORCED WITH KEVLAR® <b>DK2</b>	STAINLESS STEEL <b>SS</b>	GC 1873T D2K H SS K 8	GC1873D2KHSKV/000	18/SS873AB	203,2	8	609,6	24	3500	787	5,26	3,53
	HEAT STABILIZED THERMOPLASTIC <b>HS</b>											



Standard packaging:  
Rolls of 3,048 m (10 feet)



**TAB PLASTIC FLIGHTS**  
**½" PITCH ROLLER CHAIN (ASA 40 SIDEBOW)**  
**LONG FINGERS RUBBER PAD**  
**THICKNESS 3,3 mm (0.130")**  
**HINGE 19,85 mm (0.781")**

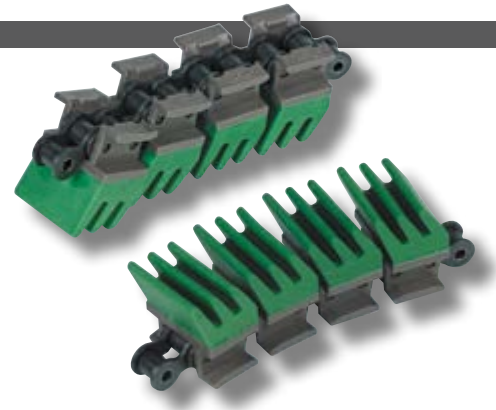

POWERED  
BY BASE ROLLER  
CHAIN MADE  
BY REGINA  
IN ITALY

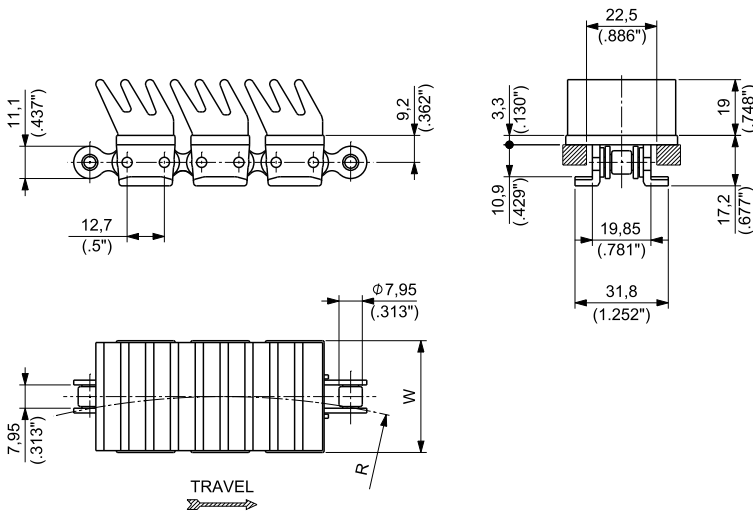

Materials  
see page 12



Sprockets  
see page 153



Corner tracks  
see page 323



Applications  
see page 20

MATERIALS			ITEM DESCRIPTION	PART NUMBER	CONNECTING LINK PART NUMBER	WIDTH W	SIDEFLEXING RADIUS R	WORKING LOAD (25°C/77°F)	WEIGHT
Flight	Base chain	Rubber				mm inch	mm R inch	N lbs	kg/m lbs/ft
	CARBON STEEL		EW 1843T UP K 1 ½	EW1843UPKW/000	18/1843	38,1 1.5	254 10	2600 584	1,28 0.86
ULTRA PERFORMANCE HOMOPOLYMER DELRIN®		THERMOPLASTIC							
<b>UP</b>		<b>TPE</b>							
	STAINLESS STEEL	Hardness: 50 ShA	EW 1843T UP SS K 1 ½	EW1843UPSKW/000	18/SS1843	38,1 1.5	254 10	2000 450	1,29 0.87



Standard packaging:  
Rolls of 3,048 m (10 feet)

**TAB PLASTIC PLATES**  
**SHORT FINGERS RUBBER PAD**  
**REDUCED SIDEFLEXING RADIUS**  
**THICKNESS 4,8 mm (0.189")**  
**HINGE 42,9 mm (1.689")**

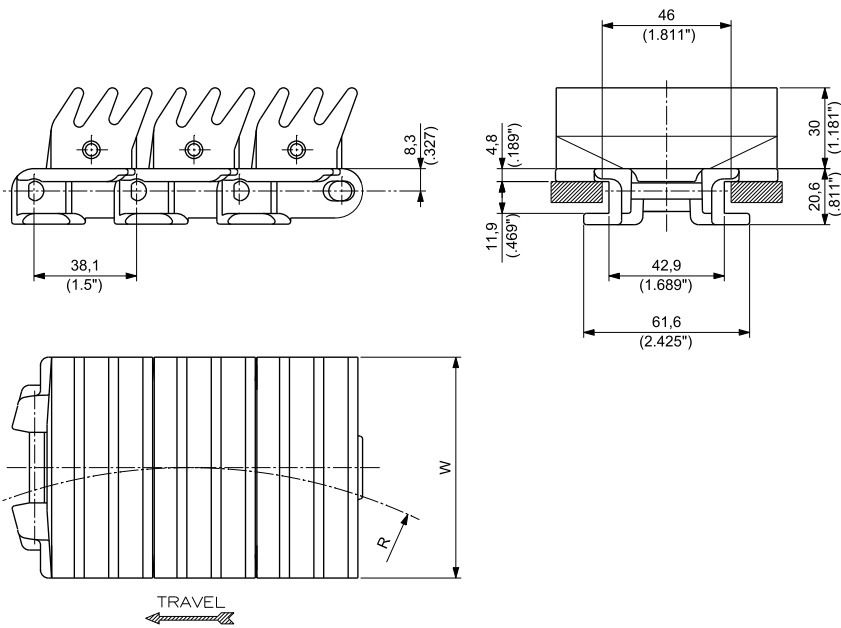
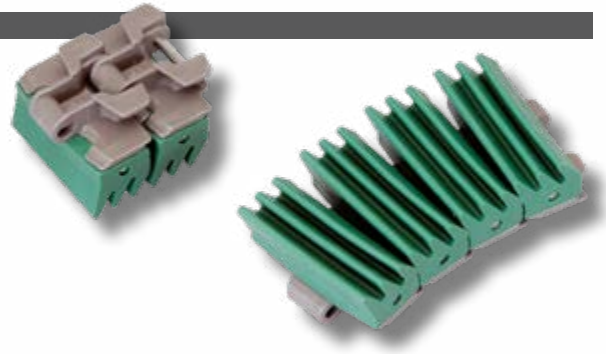

Materials  
see page 12



Sprockets  
see pages 147÷149



Applications  
see page 20

MATERIALS			ITEM DESCRIPTION	PART NUMBER	WIDTH W		SIDEFLEXING RADIUS		WORKING LOAD (25°C/77°F)		WEIGHT	
Plate	Pin	Rubber			mm	inch	mm	R inch	N	lbs	kg/m	lbs/ft
ULTRA PERFORMANCE HOMOPOLYMER DELRIN® <b>UP</b>	AUSTENITIC STAINLESS STEEL	THERMOPLASTIC <b>TPE</b> Hardness: 50 ShA	GW 878T UP K 3 ¼	GW878UPKD/000	82,6	3.25	250	9.84	2000	450	3,38	2.27



Standard packaging:  
Rolls of 3,048 m (10 feet)

**TAB PLASTIC PLATES**  
**LONG FINGERS RUBBER PAD**  
**REDUCED SIDEFLEXING RADIUS**  
**THICKNESS 4,8 mm (0.189")**  
**HINGE 42,9 mm (1.689")**

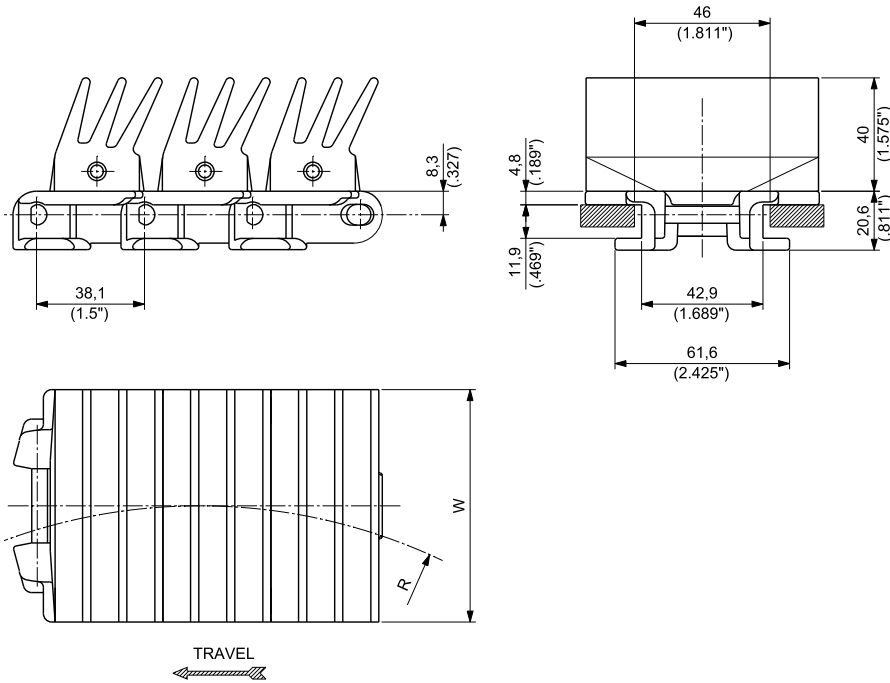
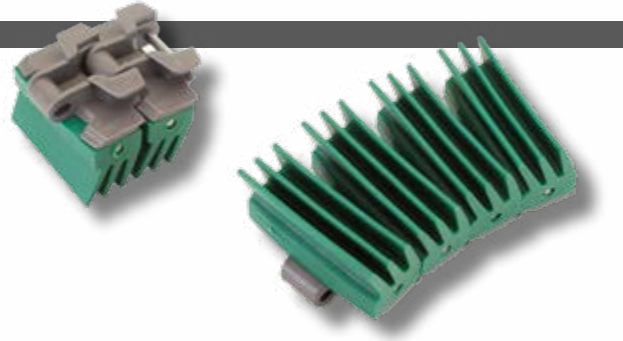

FliteTop



Materials  
see page 12



Sprockets  
see pages 147÷149



Applications  
see page 20

MATERIALS			ITEM DESCRIPTION	PART NUMBER	WIDTH W		SIDEFLEXING RADIUS R		WORKING LOAD (25°C/77°F)		WEIGHT	
Plate	Pin	Rubber			mm	inch	mm	inch	N	lbs	kg/m	lbs/ft

ULTRA PERFORMANCE  
HOMOPOLYMER DELRIN®

UP

AUSTENITIC  
STAINLESS STEEL

THERMOPLASTIC

TPE

Hardness: 50 Sha

EW 878T UP K 3 ¼ EW878UPKD/000

82,6

3.25

250

9.84

2000

450

3,38

2.27



Standard packaging:  
Rolls of 3,048 m (10 feet)

**TAB PLASTIC PLATES**  
**D-SHAPE RUBBER PAD**  
**REDUCED SIDEFLEXING RADIUS**  
**THICKNESS 4,8 mm (0.189")**  
**HINGE 42,9 mm (1.689")**

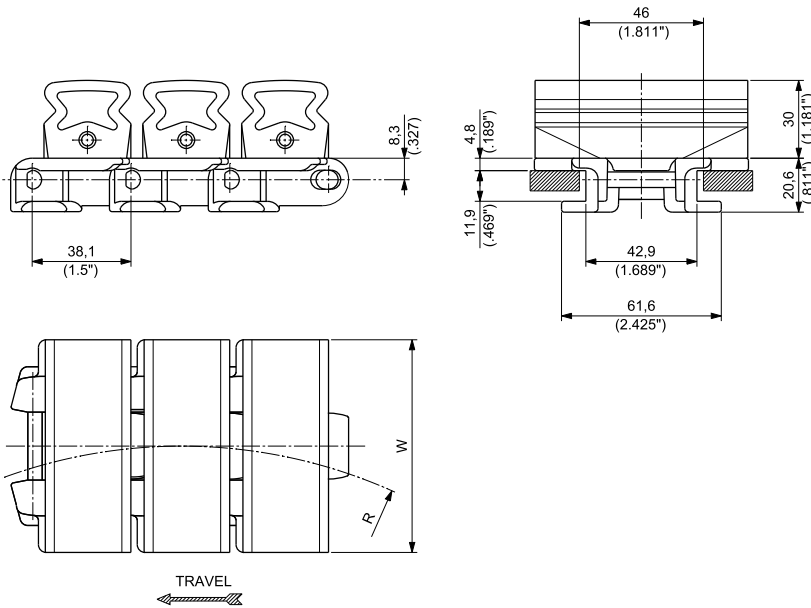
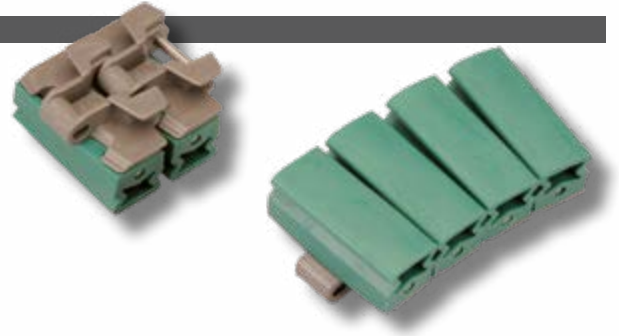

Materials  
see page 12



Sprockets  
see pages 147÷149



Applications  
see page 20

MATERIALS			ITEM DESCRIPTION	PART NUMBER	WIDTH W		SIDEFLEXING RADIUS		WORKING LOAD (25°C/77°F)		WEIGHT	
Plate	Pin	Rubber			mm	inch	mm	inch	N	lbs	kg/m	lbs/ft
ULTRA PERFORMANCE HOMOPOLYMER DELRIN® <b>UP</b>	AUSTENITIC STAINLESS STEEL	THERMOPLASTIC <b>TPE</b> Hardness: 50 ShA	GD 878T UP K 3 ¼	GD878UPKD/000	82,6	3.25	250	9.84	2000	450	3,38	2.27



Standard packaging:  
Rolls of 3,048 m (10 feet)

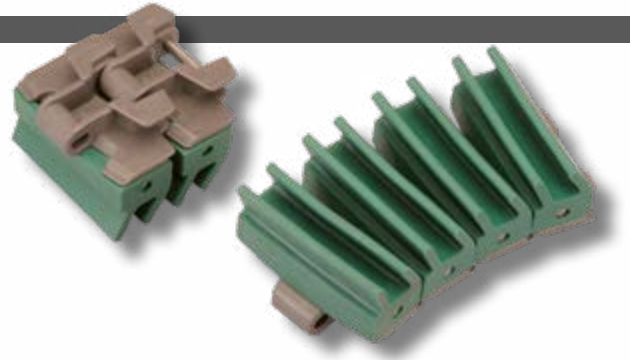

**TAB PLASTIC PLATES**  
**U-SHAPE RUBBER PAD**  
**REDUCED SIDEFLEXING RADIUS**  
**THICKNESS 4,8 mm (0.189")**  
**HINGE 42,9 mm (1.689")**

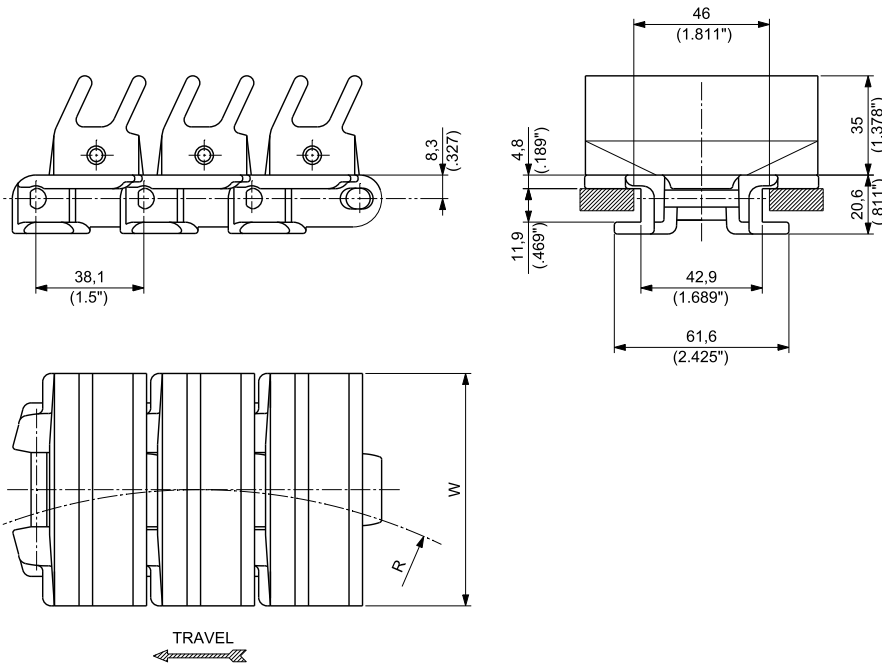

FliteTop

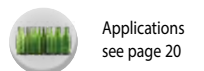
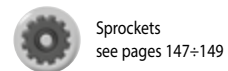
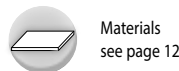

MATERIALS			ITEM DESCRIPTION	PART NUMBER	WIDTH W		SIDEFLEXING RADIUS R		WORKING LOAD (25°C/77°F)		WEIGHT	
Plate	Pin	Rubber			mm	inch	mm	inch	N	lbs	kg/m	lbs/ft

ULTRA PERFORMANCE HOMOPOLYMER DELRIN® <b>UP</b>	AUSTENITIC STAINLESS STEEL	THERMOPLASTIC <b>TPE</b> Hardness: 50 ShA	GU 878T UP K 3 ¼	GU878UPKD/000	82,6	3.25	250	9.84	2000	450	3,38	2.27
--	----------------------------	---	------------------	---------------	------	------	-----	------	------	-----	------	------

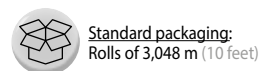



PERFORMANCE IN MOTION

***FliteTop***<sup>®</sup>

**LBP Chains  
(Low Back-Line Pressure)**





## INDUSTRIES AND APPLICATIONS

### LBP CHAINS

Suitable for handling packaged products like cartons, shrink packs, crates.

#### INDUSTRIES

Bottling and canning  
Food filling  
Warehouse & distribution

#### APPLICATIONS

Packaged product convey in accumulation sections



## FEATURES

- High ratio in outside/inside roller diameter: better rotation capability and lower coefficient of friction with products are guaranteed.
- UP material rollers paired with premium surface finish of stainless steel pins minimize friction preventing product damage caused by the accumulation force.
- On larger chain widths additional supports for pins keep a flat handling surface for the maximum product stability.
- Availability of modular transfer plates with rollers to guarantee a smooth product head transfer between two conveyors (see page 328).



## DOUBLE HINGE

PITCH 1 1/2" (38,1 mm)

THICKNESS 4,8 mm (0.189")

HINGE 136,5 mm (5.374")

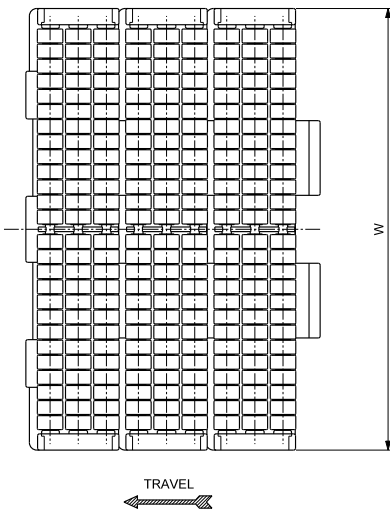
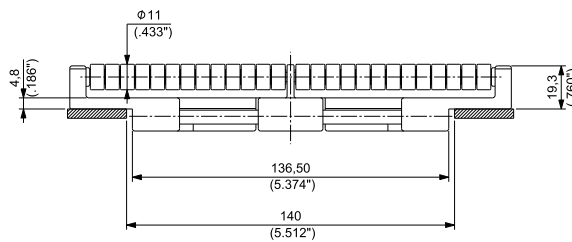
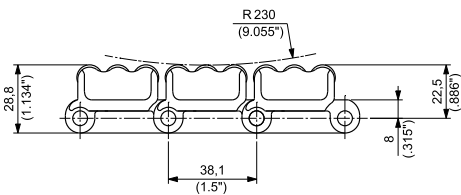

Materials  
see page 12



Sprockets  
see pages 145÷146



Applications  
see page 20

MATERIALS		ITEM DESCRIPTION	PART NUMBER	WIDTH W		PLATE THICKNESS		WORKING LOAD (25°C/77°F)		WEIGHT	
Plate	Pin			mm	inch	mm	inch	N	lbs	kg/m	lbs/ft
ULTRA PERFORMANCE HOMOPOLYMER DELRIN® <b>UP</b>	AUSTENITIC STAINLESS STEEL	LBP 821 UP K 7 1/2	LBP821UPKL/000	190,5	7.50	4,8	0.19	2750	618	5,63	3.78
		LBP 821 UP K 10	LBP821UPKM/000	254,0	10.00	4,8	0.19	2750	618	7,07	4.75
		LBP 821 UP K 12	LBP821UPKN/000	304,8	12.00	4,8	0.19	2750	618	8,22	5.53



Standard packaging:  
Rolls of 1,524 m (5 feet)

**HEAVY DUTY SINGLE HINGE**  
**PITCH 1 ½" (38,1 mm)**  
**THICKNESS 4,8 mm (0.189")**  
**HINGE 57 mm (2.244")**

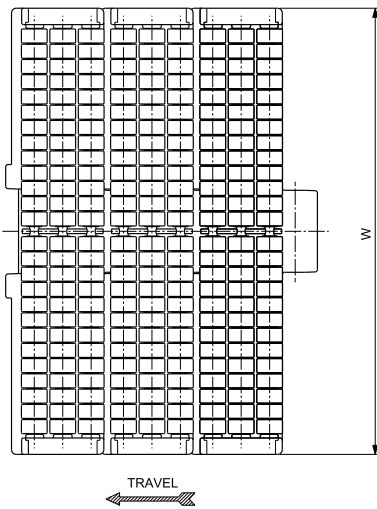
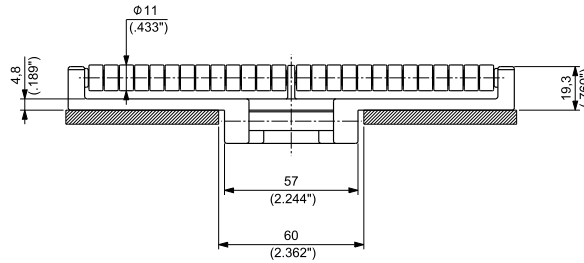
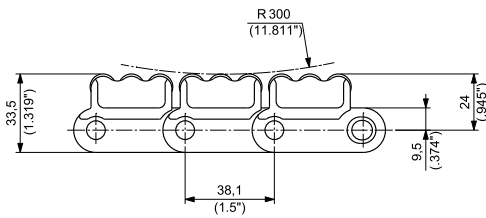

FliteTop

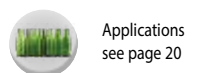
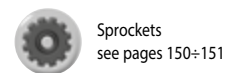
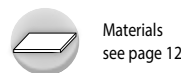

MATERIALS		ITEM DESCRIPTION	PART NUMBER	WIDTH W		PLATE THICKNESS		WORKING LOAD (25°C/77°F)		WEIGHT	
Plate	Pin			mm	inch	mm	inch	N	lbs	kg/m	lbs/ft
ULTRA PERFORMANCE HOMOPOLYMER DELRIN® <b>UP</b>	AUSTENITIC STAINLESS STEEL	LBP 8257 UP K 7 ½	LBP8257UPKL/000	190,5	7.50	4,8	0.19	3910	879	5,47	3.68
		LBP 8257 UP K 10	LBP8257UPKM/000	254,0	10.00	4,8	0.19	3910	879	6,93	4.66
		LBP 8257 UP K 12	LBP8257UPKN/000	304,8	12.00	4,8	0.19	3910	879	8,09	5.44

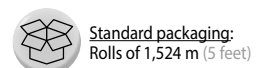

**TAB**  
**HEAVY DUTY SINGLE HINGE**  
**PITCH 1 1/2" (38,1 mm)**  
**THICKNESS 4,8 mm (0.189")**  
**HINGE 57 mm (2.244")**

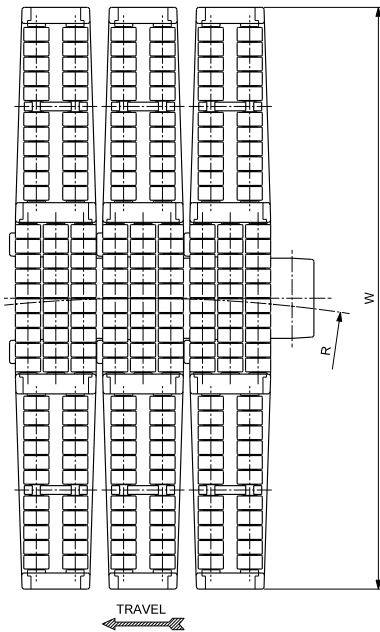
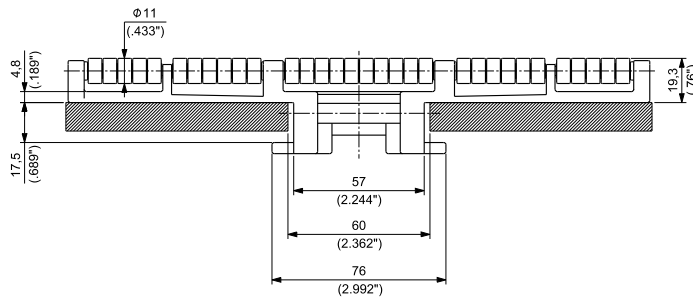
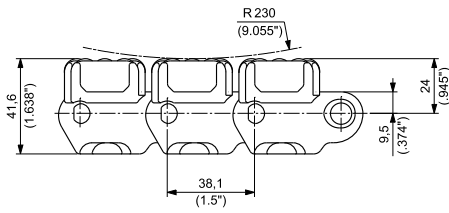

Materials  
see page 12



Sprockets  
see pages 150÷152



Corner tracks  
see page 321



Applications  
see page 20

MATERIALS		ITEM DESCRIPTION	PART NUMBER	WIDTH W		PLATE THICKNESS		SIDEFLEXING RADIUS R		WORKING LOAD (25°C/77°F)		WEIGHT	
Plate	Pin			mm	inch	mm	inch	mm	inch	N	lbs	kg/m	lbs/ft
ULTRA PERFORMANCE HOMOPOLYMER DELRIN® <b>UP</b>	AUSTENITIC STAINLESS STEEL	LBP 882T UP K 3 3/4	LBP882TUPKEA/000	95,3	3.75	4,8	0.19	667,0	26.26	3910	879	3,51	2.36
		LBP 882T UP K 4 1/2	LBP882TUPKG/000	114,3	4.50	4,8	0.19	609,6	24.00	3910	879	3,95	2.65
		LBP 882T UP K 7 1/2	LBP882TUPKL/000	190,5	7.50	4,8	0.19	609,6	24.00	3910	879	5,10	3.43
		LBP 882T UP K 10	LBP882TUPKM/000	254,0	10.00	4,8	0.19	609,6	24.00	3910	879	6,38	4.29
		LBP 882T UP K 12	LBP882TUPKN/000	304,8	12.00	4,8	0.19	609,6	24.00	3910	879	6,95	4.67



Standard packaging:  
Rolls of 1,524 m (5 feet)

**MAGNETIC**  
**HEAVY DUTY SINGLE HINGE**  
**PITCH 1 ½" (38,1 mm)**  
**THICKNESS 4,8 mm (0.189")**  
**HINGE 57 mm (2.244")**

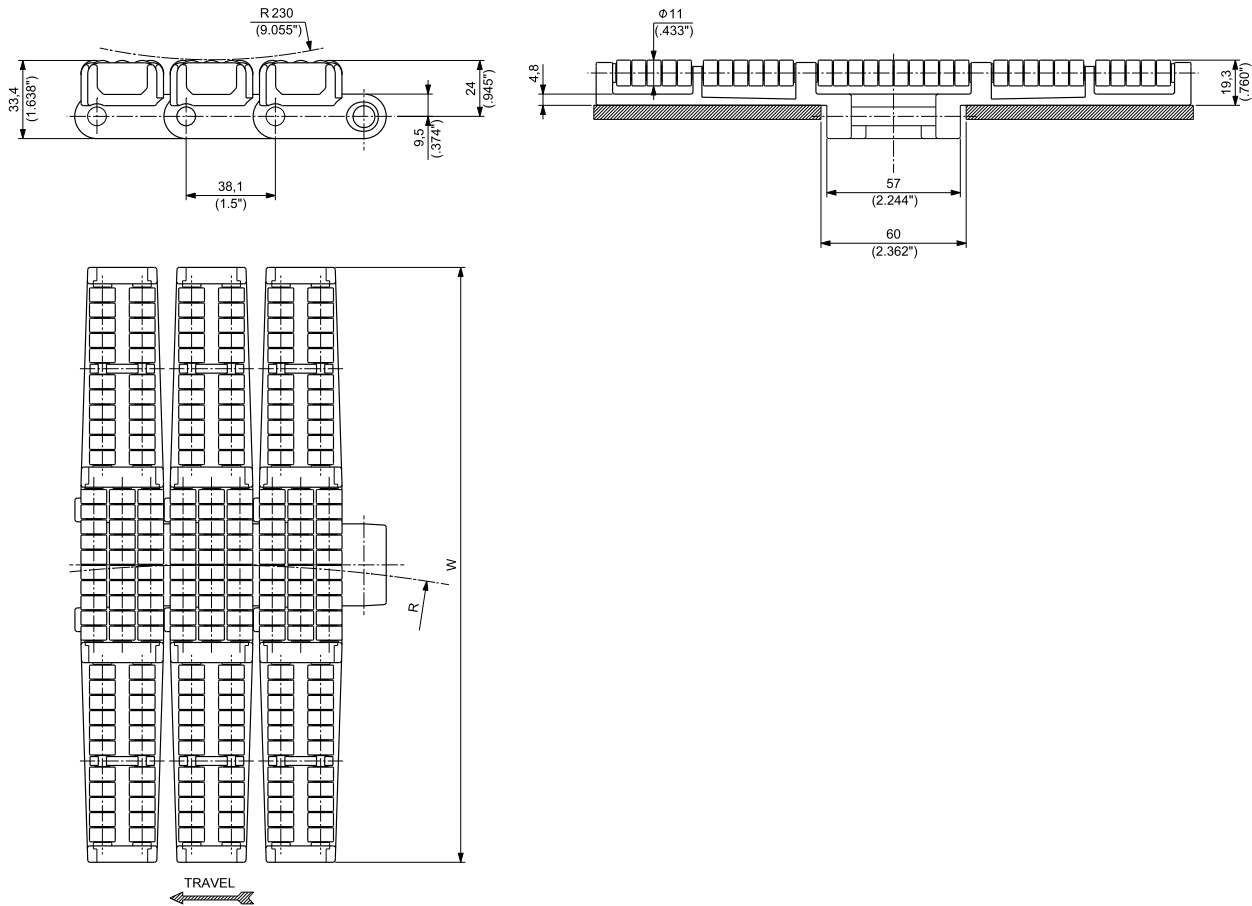

FliteTop



Materials  
see page 12



Sprockets  
see pages 150+151



Corner tracks  
see page 280



Applications  
see page 20

MATERIALS		ITEM DESCRIPTION	PART NUMBER	WIDTH W		PLATE THICKNESS		SIDEFLEXING RADIUS		WORKING LOAD (25°C/77°F)		WEIGHT	
Plate	Pin			mm	inch	mm	inch	mm <sup>R</sup>	inch	N	lbs	kg/m	lbs/ft
ULTRA PERFORMANCE HOMOPOLYMER DELRIN® <b>UP</b>	MAGNETIC STAINLESS STEEL	LBP 882M UP K 7 ½	LBP882MUPKL/000	190,5	7.50	4,8	0.19	609,6	24	3910	879	4,85	3.26
		LBP 882M UP K 10	LBP882MUPKM/000	254,0	10.00	4,8	0.19	609,6	24	3910	879	5,91	3.97
		LBP 882M UP K 12	LBP882MUPKN/000	304,8	12.00	4,8	0.19	609,6	24	3910	879	6,70	4.50



Standard packaging:  
Rolls of 1,524 m (5 feet)



PERFORMANCE IN MOTION

# ***FliteTop***<sup>®</sup>

## **Biplanar Chains**





## INDUSTRIES AND APPLICATIONS

### BIPLANAR CHAINS

Suitable for handling loose products like waxed paperboard (milk, fruit juice, etc..) in compact layout with single lane, where multiple curves with reduced sideflexing radius are required.

#### INDUSTRIES

Bottling and canning  
Food filling  
Dairy

#### APPLICATIONS

General product handling in single lane



## FEATURES

- Idler turning disc for 1700 and 1710 series used to reduce friction in the curves allowing longer center to center distance with one engine only (see page 113).
- Loose plates with holes and special pusher pins are available for the 1702 and 1701T series (see page 117). These components can be assembled by the customer on the standard biplanar chains to meet the requested product positioning in application.
- Minimum sideflexing radius of the chains allowing room reduction between conveyors, with consequent floor space saving.



**INCREASED PRODUCT SUPPORT SURFACE**  
**PITCH 50 mm (1.969")**  
**THICKNESS 4 mm (0.157")**

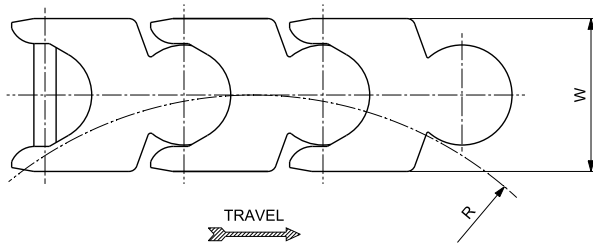
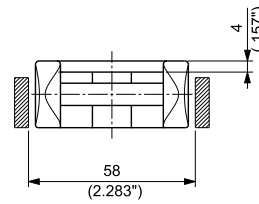
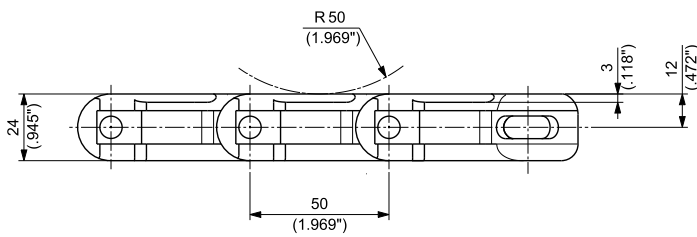

Materials  
see page 12



Sprockets  
see pages 156-157



Turning disc  
see page 113



Applications  
see page 20

MATERIALS		ITEM DESCRIPTION	PART NUMBER	WIDTH W		SIDEFLEXING RADIUS R		WORKING LOAD (25°C/77°F)		WEIGHT	
Plate	Pin			mm	inch	mm	inch	N	lbs	kg/m	lbs/ft
WHITE ACETAL RESIN <b>WA</b>	AUSTENITIC STAINLESS STEEL	C 1700	C1700/000	55	2.17	140	5.51	3000	674	1,34	0.90
ULTRA PERFORMANCE HOMOPOLYMER DELRIN® <b>UP</b>	AUSTENITIC STAINLESS STEEL	A 1700	A1700/000	55	2.17	140	5.51	3300	742	1,33	0.89
SPECIAL DELRIN® REINFORCED WITH KEVLAR® <b>DW2</b>	AUSTENITIC STAINLESS STEEL	D2K 1700A	D2K1700A/000	55	2.17	140	5.51	3000	674	1,33	0.89



Standard packaging:  
Rolls of 3,000 m (9,842 feet)

**ZERO GAP**  
**PITCH 50 mm (1.969")**  
**THICKNESS 6,0 mm (0.236")**

**NEW**

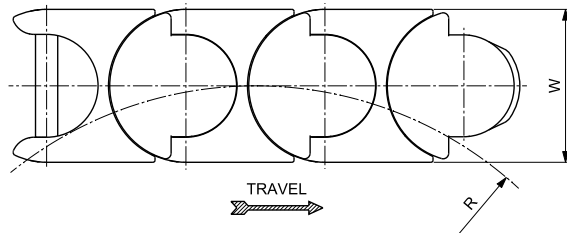
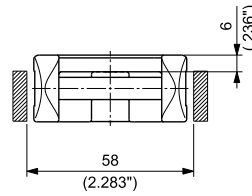
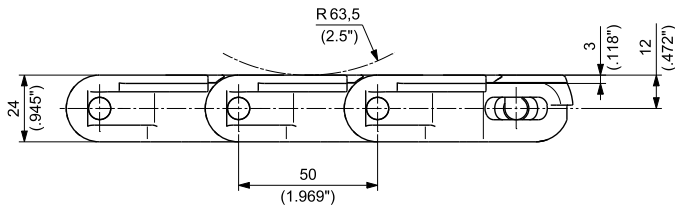
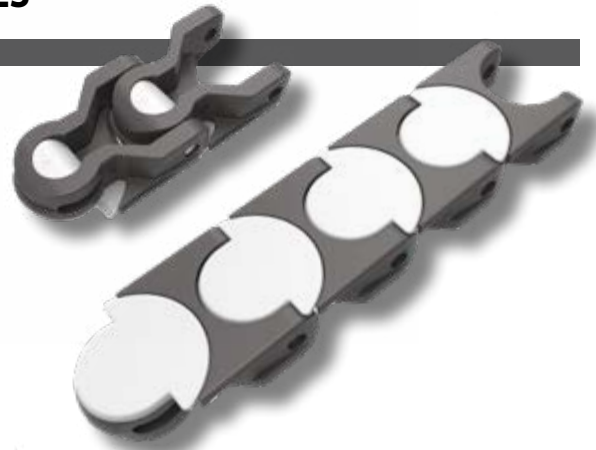

**FliteTop**



Materials see page 12



Sprockets see pages 156÷157



Turning disc see page 113



Applications see page 20

MATERIALS		ITEM DESCRIPTION	PART NUMBER	WIDTH W		SIDEFLEXING RADIUS R		WORKING LOAD (25°C/77°F)		WEIGHT	
Plate	Pin			mm	inch	mm	inch	N	lbs	kg/m	lbs/ft
WHITE ACETAL RESIN <b>WA</b>	AUSTENITIC STAINLESS STEEL	1710	1710A/000	55	2.17	125	4.92	2700	607	1,53	1.03
ULTRA PERFORMANCE HOMOPOLYMER DELRIN® <b>UP</b>	AUSTENITIC STAINLESS STEEL	UP 1710	UP1710A/000	55	2.17	125	4.92	2700	607	1,46	0.98



Standard packaging:  
Rolls of 3,000 m (9.842 feet)

## TURNING DISC

Anti-friction turning discs for 1700 and 1710 series combined with the special thermoplastic chain material allow longer chain runs and multiple turns in applications like:  
line accumulation, routing to automatic or manual inspection points, elevation or lowering to automatic or manual inspection points and product distribution.



### MATERIALS

DISCS: **PGF** REINFORCED POLYAMIDE

### CLOSED VERSION: PART NUMBER **CMT091700A00**

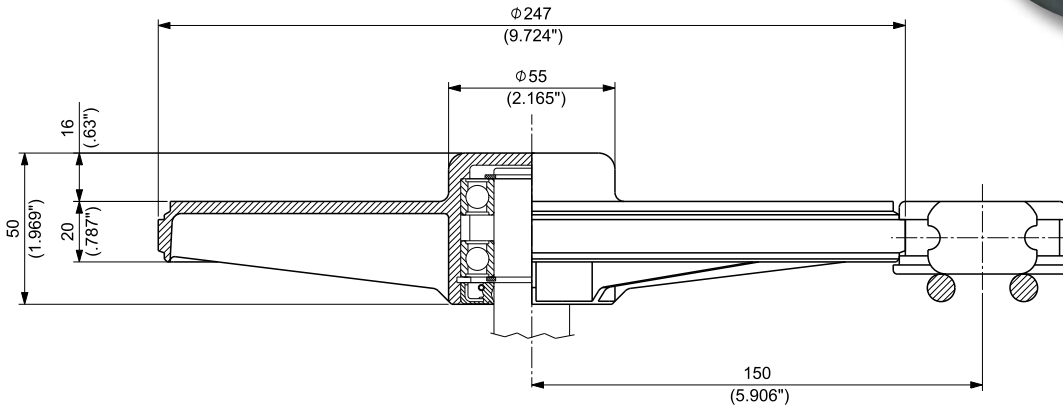

### OPEN VERSION: PART NUMBER **CMT091700C00**

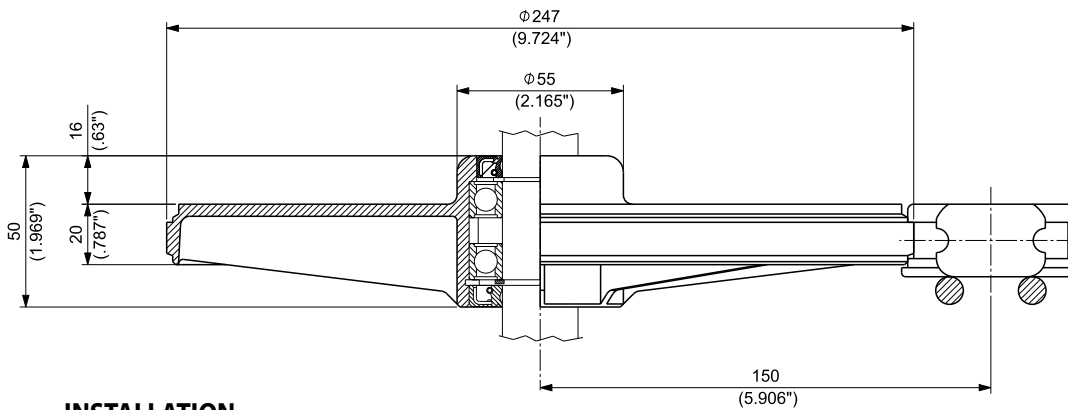

### INSTALLATION

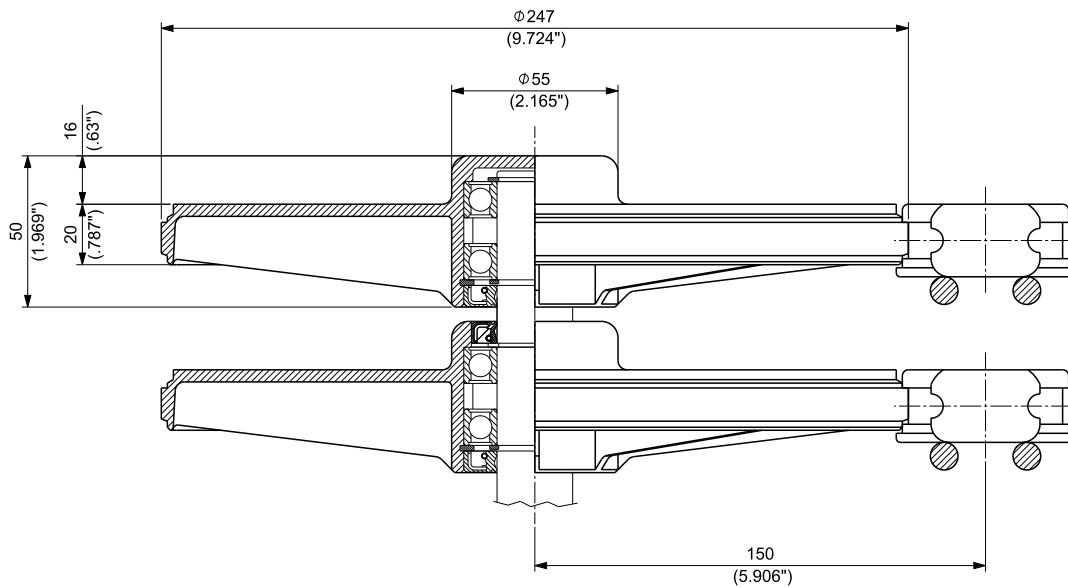

UPPER PART

RETURN PART

## TURNING DISC

### SHAFT AND TURNING DISC DIMENSIONS:

#### CLOSED VERSION

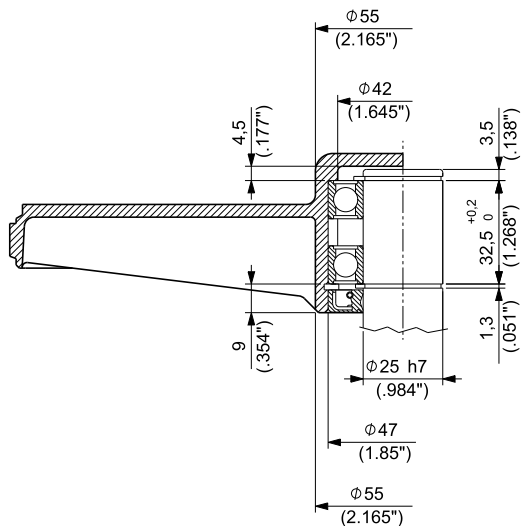

#### OPEN VERSION

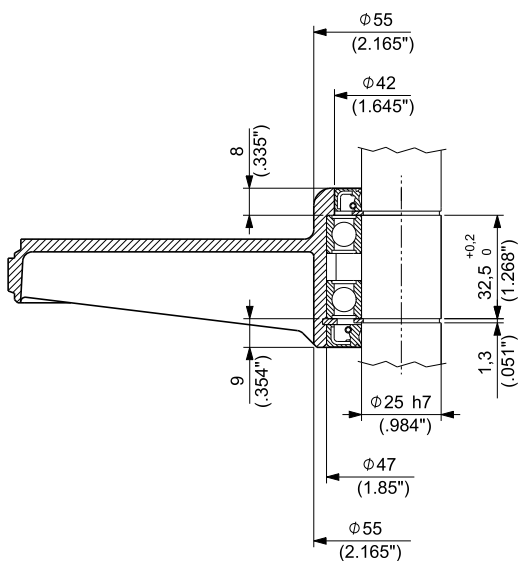

### COMPONENTS:

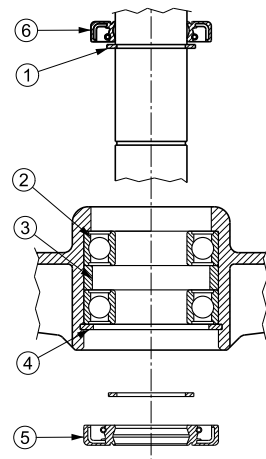
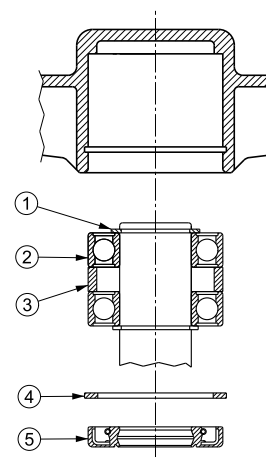

Turning discs are supplied with the following separated components:

- 1 - External retaining ring,  $\varnothing 25$  UNI 7435-25;
- 2 - Single race radial bearing with two sliding seals, 6005-2RS1 (25x47x12);
- 3 - Bearing spacer;
- 4 - Internal retaining ring,  $\varnothing 47$  UNI 7437-47;
- 5 - Seal ring with dust cover, DPSM 25477 DIN 3760 (25x47x7);
- 6 - Seal ring with dust cover, DPSM 25477 DIN 3760 (25x47x7), only for open version (CMT091700C00).

**PITCH 50 mm (1.969")**  
**THICKNESS 5,0 mm (0.197")**

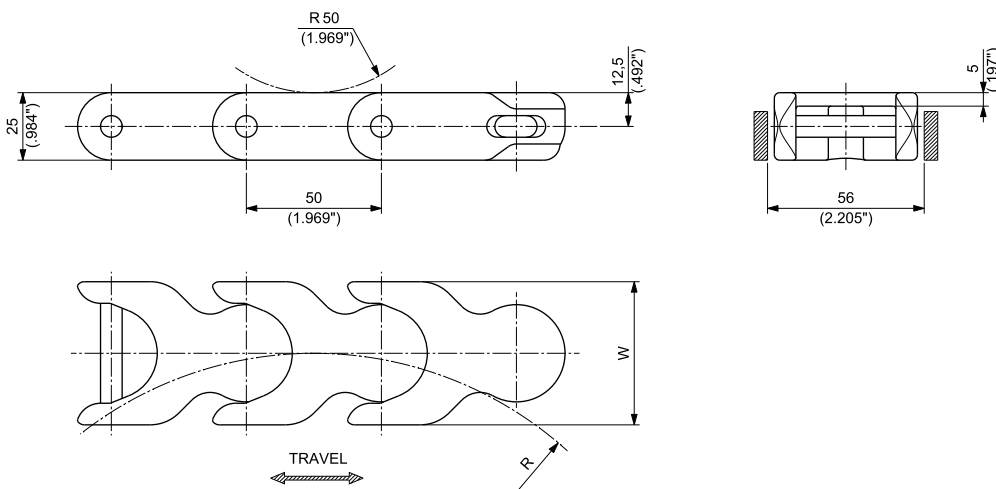
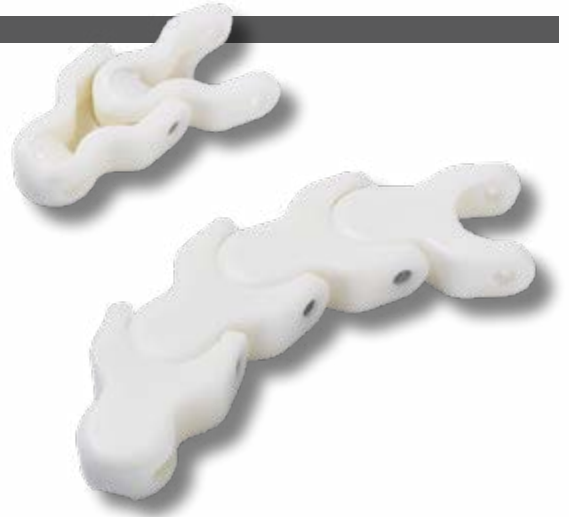

Materials  
see page 12



Sprockets  
see pages 156+157



Applications  
see page 20

MATERIALS		ITEM DESCRIPTION	PART NUMBER	WIDTH W		SIDEFLEXING RADIUS R		WORKING LOAD (25°C/77°F)		WEIGHT	
Plate	Pin			mm	inch	mm	inch	N	lbs	kg/m	lbs/ft
WHITE ACETAL RESIN 	AUSTENITIC STAINLESS STEEL	1702A	1702A/000	53	2.09	140	5.51	3300	742	1,44	0.97



Standard packaging:  
Rolls of 3,000 m (9,842 feet)



**TAB**  
**PITCH 50 mm (1.969")**  
**THICKNESS 5,0 mm (0.197")**

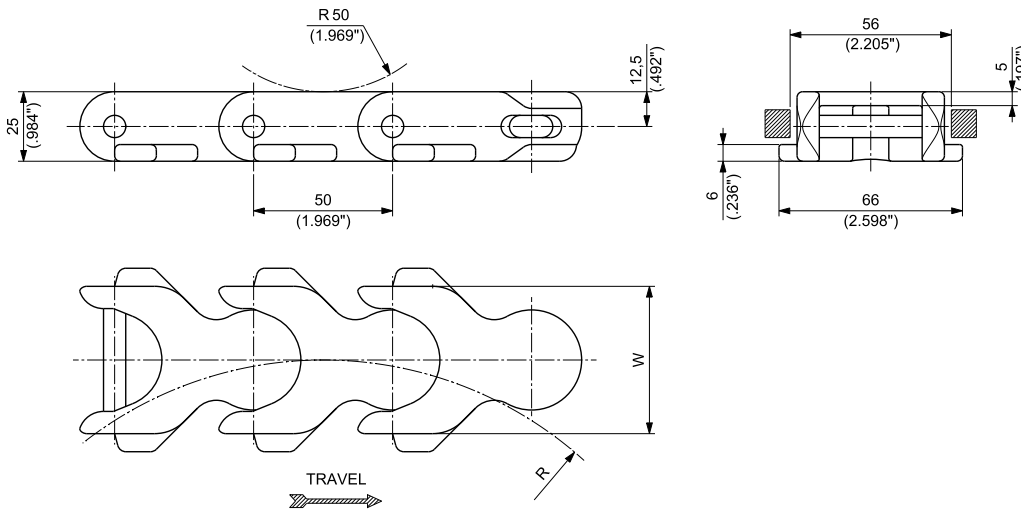
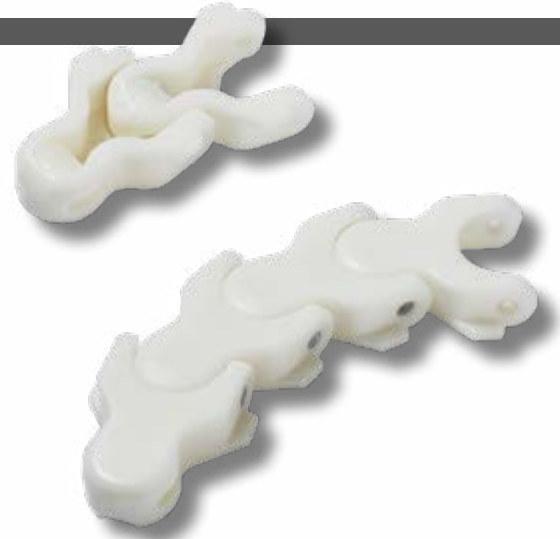

Materials  
see page 12



Sprockets  
see pages 156-157



Corner tracks  
see page 322



Applications  
see page 20

MATERIALS		ITEM DESCRIPTION	PART NUMBER	WIDTH W		SIDEFLEXING RADIUS R		WORKING LOAD (25°C/77°F)		WEIGHT	
Plate	Pin			mm	inch	mm	inch	N	kg/m	lbs/ft	
WHITE ACETAL RESIN <b>WA</b>	AUSTENITIC STAINLESS STEEL	1701TA	1701TA/000	53	2.09	140	5.51	3300	647	1,48	0.99
ULTRA PERFORMANCE HOMOPOLYMER DELRIN® <b>UP</b>	AUSTENITIC STAINLESS STEEL	UP 1701TA	UP1701TA/000	53	2.09	140	5.51	3000	647	1,42	0.95
SPECIAL DELRIN® REINFORCED WITH KEVLAR® <b>D2K</b>	AUSTENITIC STAINLESS STEEL	D2K 1701TA	D2K1701TA/000	53	2.09	140	5.51	3000	647	1,40	0.94



Standard packaging:  
Rolls of 3,000 m (9.842 feet)

## 1702 AND 1701T SERIES WITH PUSHERS

REGINA can supply, on request, loose flights with holes plus pins and pushers which the customer can assemble on the standard biplanar chains type 1702 and 1701T.

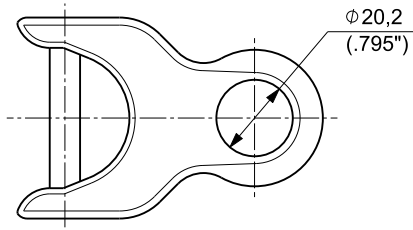

PART NUMBER: **136/1702**

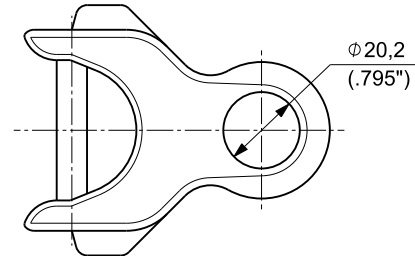

PART NUMBER: **136/1701T**

**Two types of pushers are available:**

### TYPE "S" PUSHERS

With possibility of product accumulation.  
This type of pusher has a rounded shape which allows some products accumulation.

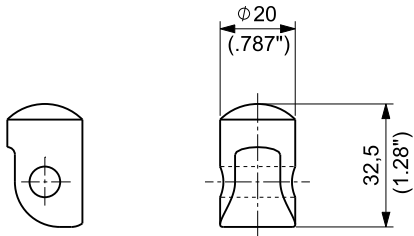

PART NUMBER: **232/1700**

### TYPE "L" PUSHERS

With no possibility of product accumulation.  
This type of pusher has an height that prevents any products accumulation.

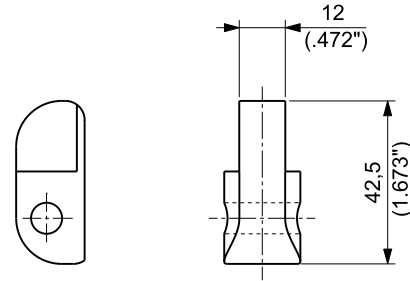

PART NUMBER: **233/1700**

Example of 1702 chain with pushers:

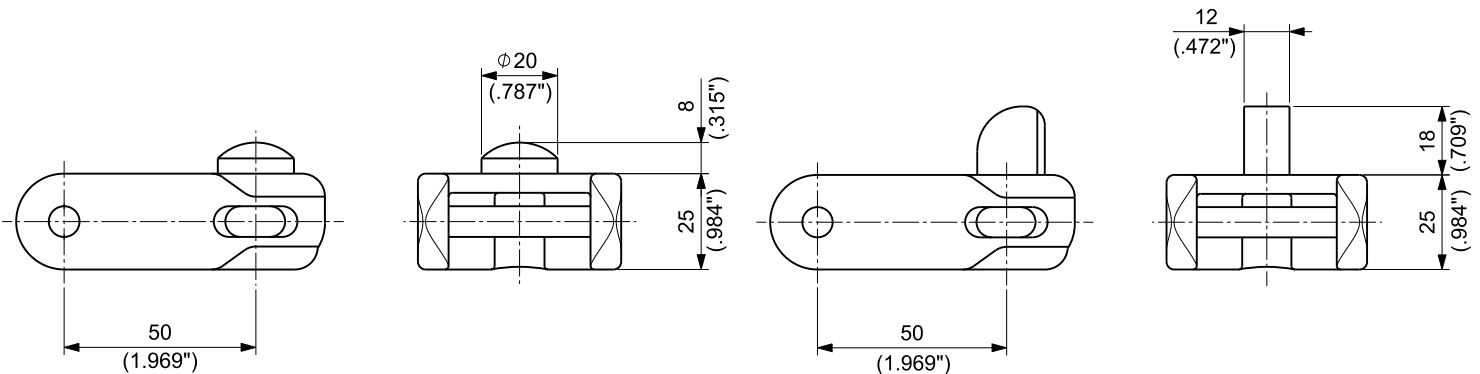



PERFORMANCE IN MOTION

# *FliteTop*<sup>®</sup> Sprockets for Chains

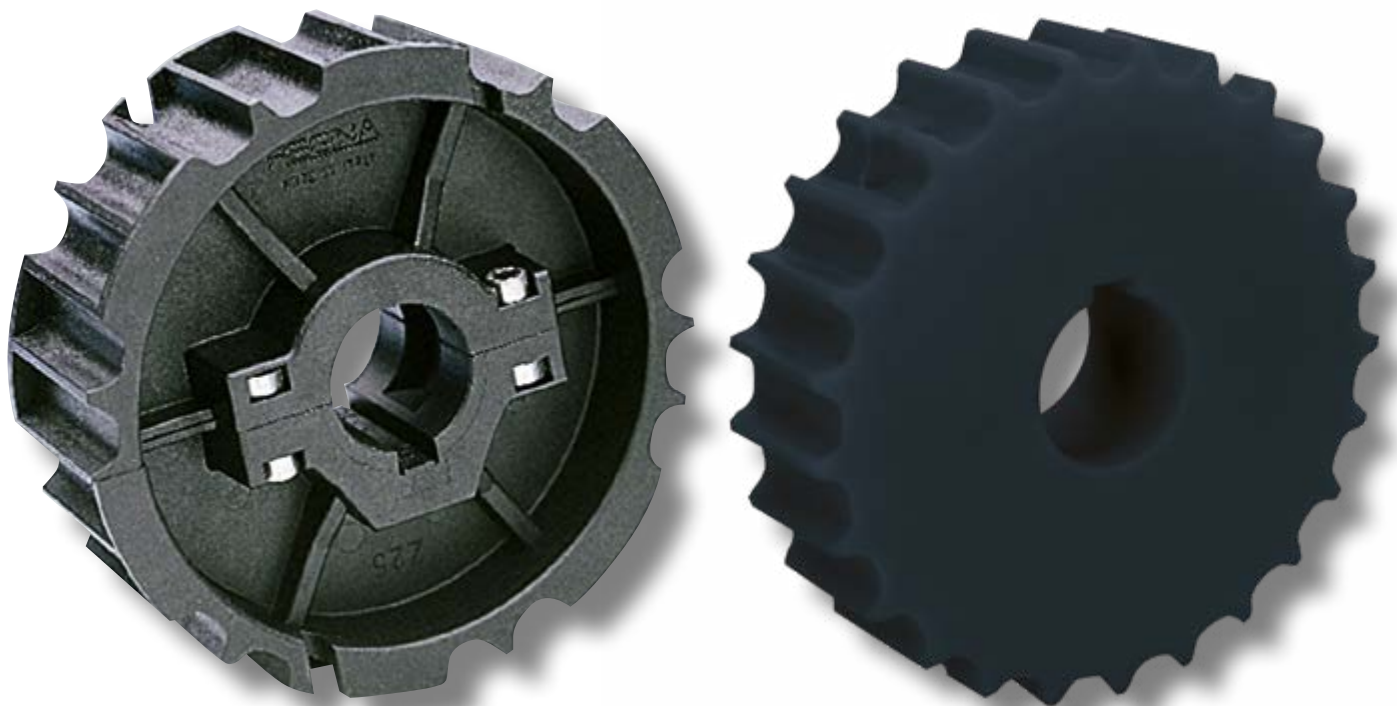

## SPROCKETS SERIES INDEX

815 series	PAGES	120÷123
250 series	PAGES	124÷127
2815 series	PAGES	128÷131
9157 series	PAGES	122÷133
803 series	PAGE	134
881 series	PAGES	135÷140
820 series	PAGES	141÷144
821 series	PAGES	145÷146
880 series	PAGES	147÷149
882 series	PAGES	150÷152
A40 series	PAGE	153
A60 series	PAGE	154
A80 series	PAGE	155
1700 series	PAGES	156÷157

## CHAIN SERIES INDEX

CHAIN SERIES INDEX	SPROCKETS
915, PHD 915, PHDG 915, 981M, PHD 981M, PHDG 981M series	PAGE 120
2815, PHDG 2815 series	PAGE 128
PHD 9157, PHDG 9157, PHD 9857M, PHDG 9857M series	PAGE 132
803 series	PAGE 134
881, 881T, 981, 981T, 982T, PHDG 981T series	PAGE 135
820, 831, HFX 820 series	PAGE 143
821, HFX 821, LBP 821 series	PAGE 145
828, 880, 879, 880T, 879T, 880M RG, 878T, 880TA, HFX 880T, EW 878T, GW 878T, GD 878T, GU 878T series	PAGE 149
8257, 882, 882T, 882M, HFX 8257, HFX 882T, HFX 882M, LBP 8257, LBP 882T, LBP 882M series	PAGE 150
843, 845, RR 845, HF RR 845, 1843T, EW 1843T series	PAGE 153
1864, 1874T, 863, 1863T, 1873T, HFX 1873T, GV 1874, EV 1874T, GW 1873T, EW 1873T, GD 1873T, GU 1873T, GC 1873T series	PAGE 154
1883, HFX 1883 series	PAGE 155
1700, 1710, 1702, 1701T series	PAGE 156

## SUITABLE FOR CHAINS:

- 915 / PHD 915
- PHDG 915
- 981M / PHD 981M
- PHDG 981M

## MATERIALS

SPROCKETS:	<b>PGF</b>	REINFORCED POLYAMIDE
SCREWS:	<b>SS</b>	STAINLESS STEEL
NUTS:	<b>B+NC</b>	NICKEL PLATED BRASS



## 19T & 21T SPROCKETS

(for 23T & 25T see next page)

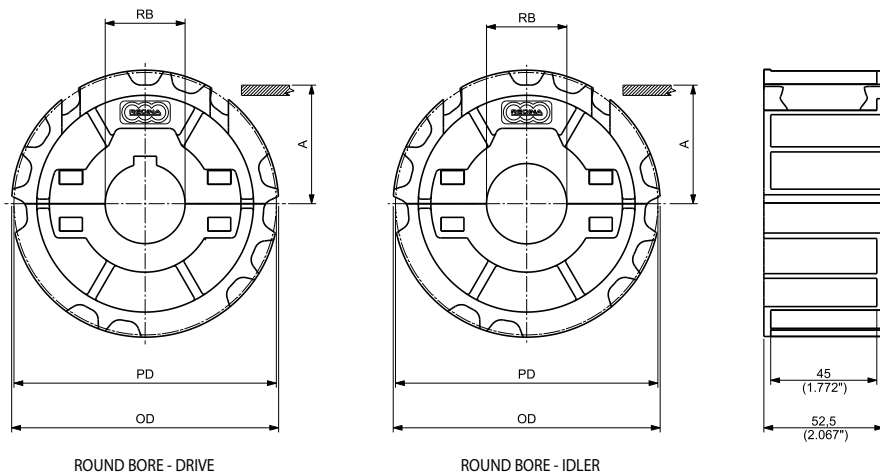

ROUND BORE - DRIVE

ROUND BORE - IDLER

## MOULDED SPLIT DRIVE AND IDLER SPROCKETS

N. TEETH	PITCH DIAMETER PD		OUTSIDE DIAMETER OD		WEAR STRIP POSITIONING A		BORE SIZE*	PART NUMBER ROUND BORE RB		WEIGHT	
	mm	inch	mm	inch	mm	inch		DRIVE	IDLER	Kg	lbs
19	117,34	4.620	117,00	4.606	62,07	2.444	25	<b>CMT028151901</b>	<b>CMT038151901</b>	0,40	0.88
							30	<b>CMT028151902</b>	<b>CMT038151902</b>	0,39	0.86
							35	<b>CMT028151903</b>	<b>CMT038151903</b>	0,38	0.84
							40	<b>CMT028151904</b>	<b>CMT038151904</b>	0,37	0.82
							45	<b>CMT028151905</b>	<b>CMT038151905</b>	0,36	0.79
							1	<b>CMT028151906</b>	<b>CMT038151906</b>	0,40	0.88
							1 ¼	<b>CMT028151908</b>	<b>CMT038151908</b>	0,39	0.86
							1 ⅜	<b>CMT028151911</b>	<b>CMT038151911</b>	0,39	0.86
							1 7/16	<b>CMT028151909</b>	<b>CMT038151909</b>	0,38	0.84
							1 ½	<b>CMT028151910</b>	<b>CMT038151910</b>	0,37	0.82
21	129,30	5.091	130,00	5.118	68,05	2.679	25	<b>CMT028152101</b>	<b>CMT038152101</b>	0,52	1.15
							30	<b>CMT028152102</b>	<b>CMT038152102</b>	0,51	1.12
							35	<b>CMT028152103</b>	<b>CMT038152103</b>	0,50	1.10
							40	<b>CMT028152104</b>	<b>CMT038152104</b>	0,48	1.06
							45	<b>CMT028152105</b>	<b>CMT038152105</b>	0,47	1.04
							1	<b>CMT028152106</b>	<b>CMT038152106</b>	0,52	1.15
							1 ¼	<b>CMT028152108</b>	<b>CMT038152108</b>	0,51	1.12
							1 ⅜	<b>CMT028152111</b>	<b>CMT038152111</b>	0,50	1.10
							1 7/16	<b>CMT028152109</b>	<b>CMT038152109</b>	0,49	1.08
							1 ½	<b>CMT028152110</b>	<b>CMT038152110</b>	0,49	1.08

\*Diameter is indicated.

\*\* Imperial round bore drive sprockets are supplied with setscrew. Metric round bore drive sprockets are supplied without setscrew.

## SUITABLE FOR CHAINS:

- 915 / PHD 915
- PHDG 915
- 981M / PHD 981M
- PHDG 981M

## MATERIALS

SPROCKETS: **PGF** REINFORCED POLYAMIDE

SCREWS: **SS** STAINLESS STEEL

NUTS: **B+NC** NICKEL PLATED BRASS



## 23T & 25T SPROCKETS

(for 19T & 21T see previous page)

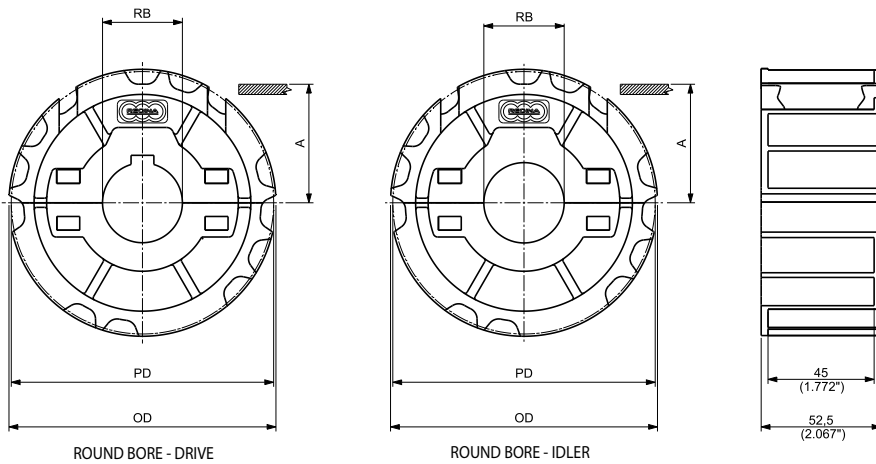

## MOULDED SPLIT DRIVE AND IDLER SPROCKETS

N. TEETH	PITCH DIAMETER PD		OUTSIDE DIAMETER OD		WEAR STRIP POSITIONING A		BORE SIZE*		PART NUMBER ROUND BORE RB		WEIGHT	
	mm	inch	mm	inch	mm	inch	mm	inch**	DRIVE	IDLER	Kg	lbs
23	141,20	5.559	141,90	5.587	74,00	2.913	25		<b>CMT028152301</b>	<b>CMT038152301</b>	0,57	1.26
							30		<b>CMT028152302</b>	<b>CMT038152302</b>	0,56	1.23
							35		<b>CMT028152303</b>	<b>CMT038152303</b>	0,55	1.21
							40		<b>CMT028152304</b>	<b>CMT038152304</b>	0,53	1.17
							45		<b>CMT028152305</b>	<b>CMT038152305</b>	0,52	1.15
							1		<b>CMT028152306</b>	<b>CMT038152306</b>	0,57	1.26
							1 ¼		<b>CMT028152308</b>	<b>CMT038152308</b>	0,56	1.23
							1 ⅜		<b>CMT028152311</b>	<b>CMT038152311</b>	0,55	1.21
							1 ⅞		<b>CMT028152309</b>	<b>CMT038152309</b>	0,54	1.19
							1 ½		<b>CMT028152310</b>	<b>CMT038152310</b>	0,54	1.19
25	153,19	6.031	154,20	6.071	80,00	3.150	25		<b>CMT028152501</b>	<b>CMT038152501</b>	0,62	1.37
							30		<b>CMT028152502</b>	<b>CMT038152502</b>	0,61	1.34
							35		<b>CMT028152503</b>	<b>CMT038152503</b>	0,60	1.32
							40		<b>CMT028152504</b>	<b>CMT038152504</b>	0,59	1.30
							45		<b>CMT028152505</b>	<b>CMT038152505</b>	0,57	1.26
							1		<b>CMT028152506</b>	<b>CMT038152506</b>	0,62	1.37
							1 ¼		<b>CMT028152508</b>	<b>CMT038152508</b>	0,61	1.34
							1 ⅜		<b>CMT028152511</b>	<b>CMT038152511</b>	0,60	1.32
							1 ⅞		<b>CMT028152509</b>	<b>CMT038152509</b>	0,60	1.32
							1 ½		<b>CMT028152510</b>	<b>CMT038152510</b>	0,59	1.30

\*Diameter is indicated.

\*\* Imperial round bore drive sprockets are supplied with setscrew. Metric round bore drive sprockets are supplied without setscrew.



## SUITABLE FOR CHAINS:

- 915 / PHD 915
- PHDG 915
- 981M / PHD 981M
- PHDG 981M

## MATERIALS

SPROCKETS:	<b>PA</b>	POLYAMIDE
SCREWS:	<b>SS</b>	STAINLESS STEEL
NUTS:	<b>B</b>	BRASS



## 17T, 19T & 21T SPROCKETS

(for 23T, 25T & 27T see next page)

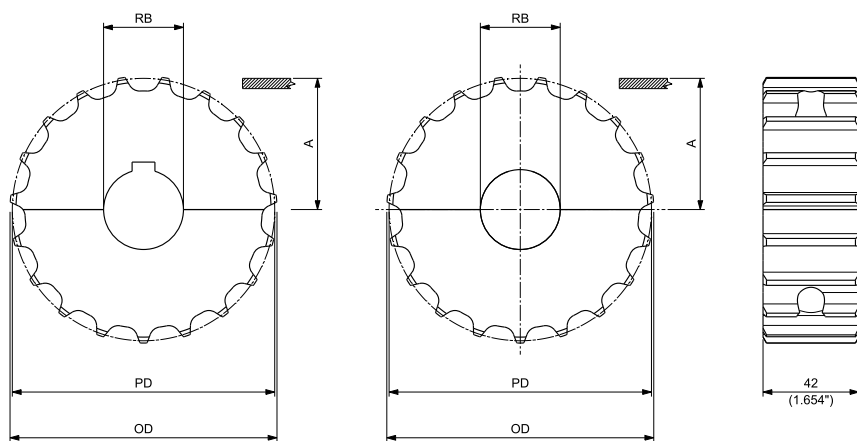

ROUND BORE - DRIVE

ROUND BORE - IDLER

## MACHINED SPLIT DRIVE AND IDLER SPROCKETS

N. TEETH	PITCH DIAMETER PD		OUTSIDE DIAMETER OD		WEAR STRIP POSITIONING A		BORE SIZE*		PART NUMBER ROUND BORE RB		WEIGHT	
	mm	inch	mm	inch	mm	inch	mm	inch**	DRIVE	IDLER	Kg	lbs
17	105,47	4.152	104,40	4.110	56,34	2.218	25		<b>CMAS028151725</b>	<b>CMAS038151725</b>	0,36	0.80
							30		<b>CMAS028151730</b>	<b>CMAS038151730</b>	0,35	0.78
							35		<b>CMAS028151735</b>	<b>CMAS038151735</b>	0,34	0.75
							40		<b>CMAS028151740</b>	<b>CMAS038151740</b>	0,33	0.72
							1		<b>CMAS0281517254</b>	<b>CMAS0381517254</b>	0,36	0.80
							1 ¼		<b>CMAS0281517317</b>	<b>CMAS0381517317</b>	0,35	0.78
							1 ⅜		<b>CMAS0281517349</b>	<b>CMAS0381517349</b>	0,35	0.78
19	117,34	4.620	117,00	4.606	62,27	2.452	25		<b>CMAS028151925</b>	<b>CMAS038151925</b>	0,45	1.00
							30		<b>CMAS028151930</b>	<b>CMAS038151930</b>	0,44	0.97
							35		<b>CMAS028151935</b>	<b>CMAS038151935</b>	0,43	0.95
							40		<b>CMAS028151940</b>	<b>CMAS038151940</b>	0,42	0.92
							1		<b>CMAS0281519254</b>	<b>CMAS0381519254</b>	0,45	1.00
							1 ¼		<b>CMAS0281519317</b>	<b>CMAS0381519317</b>	0,45	1.00
							1 ⅜		<b>CMAS0281519349</b>	<b>CMAS0381519349</b>	0,44	0.97
21	129,26	5.089	129,40	5.094	68,23	2.686	25		<b>CMAS028152125</b>	<b>CMAS038152125</b>	0,54	1.20
							30		<b>CMAS028152130</b>	<b>CMAS038152130</b>	0,57	1.26
							35		<b>CMAS028152135</b>	<b>CMAS038152135</b>	0,53	1.17
							40		<b>CMAS028152140</b>	<b>CMAS038152140</b>	0,52	1.14
							1		<b>CMAS0281521254</b>	<b>CMAS0381521254</b>	0,55	1.22
							1 ¼		<b>CMAS0281521317</b>	<b>CMAS0381521317</b>	0,55	1.22
							1 ⅜		<b>CMAS0281521349</b>	<b>CMAS0381521349</b>	0,54	1.20
		<b>CMAS0281521365</b>	<b>CMAS0381521365</b>	0,53	1.17							
		<b>CMAS0281521381</b>	<b>CMAS0381521381</b>	0,52	1.15							

\*Diameter is indicated.

\*\*Imperial round bore drive sprockets are supplied with setscrew. Metric round bore drive sprockets are supplied without setscrew.

## SUITABLE FOR CHAINS:

- 915 / PHD 915
- PHDG 915
- 981M / PHD 981M
- PHDG 981M

### MATERIALS

SPROCKETS:	<b>PA</b>	POLYAMIDE
SCREWS:	<b>SS</b>	STAINLESS STEEL
NUTS:	<b>B</b>	BRASS



## 23T, 25T & 27T SPROCKETS

(for 17T, 19T & 21T see previous page)

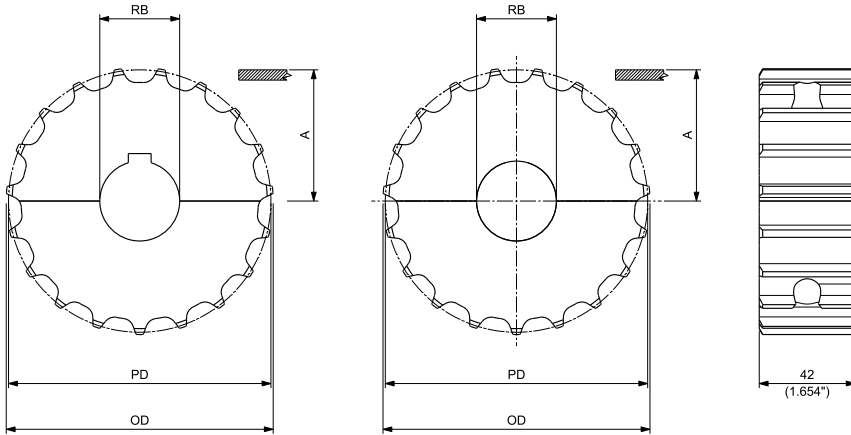

ROUND BORE - DRIVE

ROUND BORE - IDLER

## MACHINED SPLIT DRIVE AND IDLER SPROCKETS

N. TEETH	PITCH DIAMETER PD		OUTSIDE DIAMETER OD		WEAR STRIP POSITIONING A		BORE SIZE*		PART NUMBER ROUND BORE RB		WEIGHT		
	mm	inch	mm	inch	mm	inch	mm	inch**	DRIVE	IDLER	Kg	lbs	
23	141,22	5.560	141,90	5.587	74,21	2.922							
									25	<b>CMAS028152325</b>	<b>CMAS038152325</b>	0,66	1.46
									30	<b>CMAS028152330</b>	<b>CMAS038152330</b>	0,65	1.44
									35	<b>CMAS028152335</b>	<b>CMAS038152335</b>	0,64	1.41
									40	<b>CMAS028152340</b>	<b>CMAS038152340</b>	0,63	1.38
									1	<b>CMAS0281523254</b>	<b>CMAS0381523254</b>	0,66	1.46
									1 ¼	<b>CMAS0281523317</b>	<b>CMAS0381523317</b>	0,66	1.46
25	153,20	6.031	154,20	6.071	80,20	3.157							
									25	<b>CMAS028152525</b>	<b>CMAS038152525</b>	0,82	1.80
									30	<b>CMAS028152530</b>	<b>CMAS038152530</b>	0,81	1.77
									35	<b>CMAS028152535</b>	<b>CMAS038152535</b>	0,79	1.75
									40	<b>CMAS028152540</b>	<b>CMAS038152540</b>	0,78	1.71
									1	<b>CMAS0281525254</b>	<b>CMAS0381525254</b>	0,82	1.80
									1 ¼	<b>CMAS0281525317</b>	<b>CMAS0381525317</b>	0,82	1.80
27	165,21	6.504	166,40	6.551	86,20	3.394							
									25	<b>CMAS028152725</b>	<b>CMAS038152725</b>	1,01	2.22
									30	<b>CMAS028152730</b>	<b>CMAS038152730</b>	1,00	2.20
									35	<b>CMAS028152735</b>	<b>CMAS038152735</b>	0,98	2.17
									40	<b>CMAS028152740</b>	<b>CMAS038152740</b>	0,97	2.14
									1	<b>CMAS0281527254</b>	<b>CMAS0381527254</b>	1,00	2.20
									1 ¼	<b>CMAS0281527317</b>	<b>CMAS0381527317</b>	0,98	2.16
1 ¾	<b>CMAS0281527349</b>	<b>CMAS0381527349</b>	0,98	2.16									
1 7/16	<b>CMAS0281527365</b>	<b>CMAS0381527365</b>	0,97	2.14									
1 ½	<b>CMAS0281527381</b>	<b>CMAS0381527381</b>	0,97	2.14									

\*Diameter is indicated.

\*\* Imperial round bore drive sprockets are supplied with setscrew. Metric round bore drive sprockets are supplied without setscrew.

## SUITABLE FOR CHAINS:

- 915 / PHD 915
- PHDG 915
- 881
- 981 / 981M / PHD 981M
- PHDG 981M
- 820
- HFX 820
- 831
- 828
- 880 / 880M RG
- 879

## MATERIALS

SPROCKETS: **PGF** REINFORCED POLYAMIDE

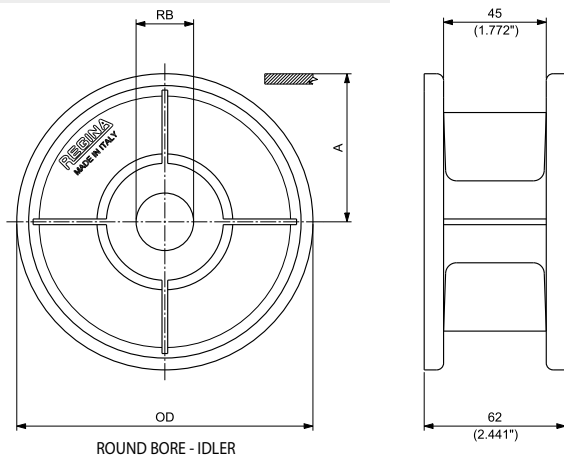

## MOULDED SOLID IDLER WHEELS

N. TEETH	OUTSIDE DIAMETER OD		WEAR STRIP POSITIONING A		BORE SIZE*		PART NUMBER ROUND BORE RB IDLER	WEIGHT	
	mm	inch	mm	inch	mm	inch		Kg	lbs
21	129,80	5.110	64,90	2.555	25		<b>CMT032502101</b>	0,22	0.48
					30		<b>CMT032502102</b>	0,22	0.49
					35		<b>CMT032502103</b>	0,22	0.49
					40		<b>CMT032502104</b>	0,20	0.44
					1		<b>CMT032502106</b>	0,22	0.49
					1 ¼		<b>CMT032502108</b>	0,21	0.47
					1 ⅜		<b>CMT032502111</b>	0,21	0.47
					1 ⅞		<b>CMT032502109</b>	0,20	0.44
23	142,30	5.602	71,15	2.801	25		<b>CMT032502301</b>	0,25	0.54
					30		<b>CMT032502302</b>	0,25	0.55
					35		<b>CMT032502303</b>	0,24	0.53
					40		<b>CMT032502304</b>	0,24	0.54
					1		<b>CMT032502306</b>	0,24	0.54
					1 ¼		<b>CMT032502308</b>	0,24	0.53
					1 ⅜		<b>CMT032502311</b>	0,24	0.53
					1 ⅞		<b>CMT032502309</b>	0,24	0.53
25	154,70	6.091	77,35	3.045	25		<b>CMT032502501</b>	0,30	0.65
					30		<b>CMT032502502</b>	0,30	0.66
					35		<b>CMT032502503</b>	0,29	0.64
					40		<b>CMT032502504</b>	0,28	0.62
					1		<b>CMT032502506</b>	0,30	0.65
					1 ¼		<b>CMT032502508</b>	0,29	0.64
					1 ⅜		<b>CMT032502511</b>	0,29	0.64
					1 ⅞		<b>CMT032502509</b>	0,29	0.64
				1 ½		<b>CMT032502510</b>	0,28	0.61	

\*Diameter is indicated.

## SUITABLE FOR CHAINS:

- 915 / PHD 915
- PHDG 915
- 881
- 981 / 981M / PHD 981M
- PHDG 981M
- 820
- HFX 820
- 831
- 828
- 880 / 880M RG

## MATERIALS

SPROCKETS: **PGF** REINFORCED POLYAMIDE

SCREWS: **SS** STAINLESS STEEL

NUTS: **S+ZN** ZINC PLATED STEEL

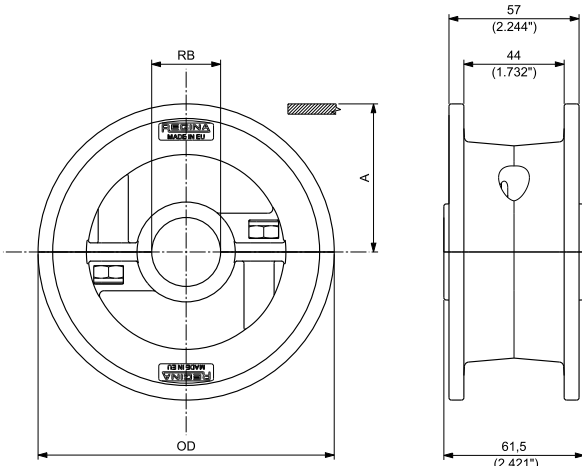

ROUND BORE - IDLER

## MOULDED SPLIT IDLER WHEELS

N. TEETH	OUTSIDE DIAMETER		WEAR STRIP POSITIONING		BORE SIZE*		PART NUMBER ROUND BORE RB IDLER	WEIGHT	
	mm	inch	mm	inch	mm	inch		Kg	lbs
21	129,80	5.110	64,90	2.555	25		<b>CMTS048152125</b>	0,33	0.72
					30		<b>CMTS048152130</b>	0,33	0.73
					35		<b>CMTS048152135</b>	0,31	0.68
					40		<b>CMTS048152140</b>	0,34	0.76
					45		<b>CMTS048152145</b>	0,31	0.69
						1	<b>CMTS0481521254</b>	0,33	0.72
						1 ¼	<b>CMTS0481521317</b>	0,32	0.71
23	142,30	5.602	71,15	2.801	25		<b>CMTS048152325</b>	0,36	0.80
					30		<b>CMTS048152330</b>	0,37	0.81
					35		<b>CMTS048152335</b>	0,35	0.76
					40		<b>CMTS048152340</b>	0,38	0.84
					45		<b>CMTS048152345</b>	0,35	0.77
						1	<b>CMTS0481523254</b>	0,36	0.80
						1 ¼	<b>CMTS0481523317</b>	0,36	0.79
25	154,70	6.091	77,35	3.045	25		<b>CMTS048152525</b>	0,40	0.89
					30		<b>CMTS048152530</b>	0,41	0.90
					35		<b>CMTS048152535</b>	0,39	0.85
					40		<b>CMTS048152540</b>	0,42	0.92
					45		<b>CMTS048152545</b>	0,39	0.86
						1	<b>CMTS0481525254</b>	0,40	0.89
						1 ¼	<b>CMTS0481525317</b>	0,40	0.88

\*Diameter is indicated.

## SUITABLE FOR CHAINS:

- 915 / PHD 915
- PHDG 915
- 881
- 981 / 981M / PHD 981M
- PHDG 981M
- 820
- HFX 820
- 831
- 828
- 880 / 880M RG
- 879

### MATERIALS

SPROCKETS:	<b>PA</b>	POLYAMIDE
SCREWS:	<b>SS</b>	STAINLESS STEEL
NUTS:	<b>B</b>	BRASS



## 17T & 19T IDLER WHEELS

(for 21T, 23T & 25T see next page)

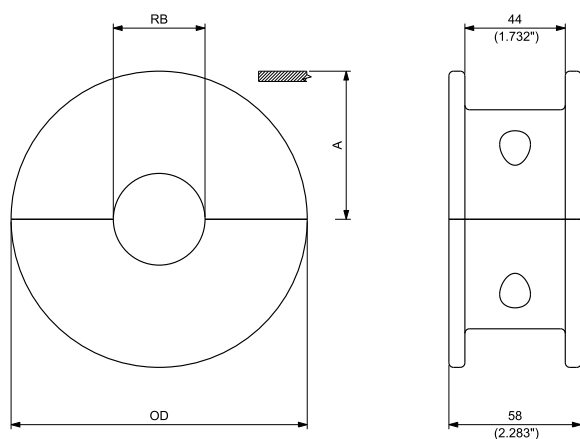

ROUND BORE - IDLER

## MACHINED SPLIT IDLER WHEELS

N. TEETH	OUTSIDE DIAMETER OD		WEAR STRIP POSITIONING A		BORE SIZE*		PART NUMBER ROUND BORE RB IDLER	WEIGHT	
	mm	inch	mm	inch	mm	inch		Kg	lbs
17	106,50	4.193	53,25	2.096	25		<b>CMAS048151725</b>	0,34	0.76
					30		<b>CMAS048151730</b>	0,33	0.73
					35		<b>CMAS048151735</b>	0,31	0.69
					40		<b>CMAS048151740</b>	0,29	0.65
					1		<b>CMAS0481517254</b>	0,34	0.76
					1 ¼		<b>CMAS0481517317</b>	0,32	0.71
					1 ⅜		<b>CMAS0481517349</b>	0,32	0.71
					1 7/16		<b>CMAS0481517365</b>	0,31	0.69
19	118,00	4.646	59,00	2.323	25		<b>CMAS048151925</b>	0,45	1.00
					30		<b>CMAS048151930</b>	0,44	0.97
					35		<b>CMAS048151935</b>	0,42	0.93
					40		<b>CMAS048151940</b>	0,40	0.89
					1		<b>CMAS0481519254</b>	0,45	1.00
					1 ¼		<b>CMAS0481519317</b>	0,42	0.92
					1 ⅜		<b>CMAS0481519349</b>	0,42	0.92
					1 7/16		<b>CMAS0481519365</b>	0,40	0.89
1 ½		<b>CMAS0481519381</b>	0,38	0.84					

\*Diameter is indicated.

## SUITABLE FOR CHAINS:

- 915 / PHD 915
- PHDG 915
- 881 / 981 / 981M / PHD 981M
- PHDG 981M
- 820 / HFX 820
- 831
- 828
- 880 / 880M RG
- 879

## MATERIALS

SPROCKETS: **PA** POLYAMIDE

SCREWS: **SS** STAINLESS STEEL

NUTS: **B** BRASS



## 21T, 23T & 25T IDLER WHEELS

(for 17T & 19T see previous page)

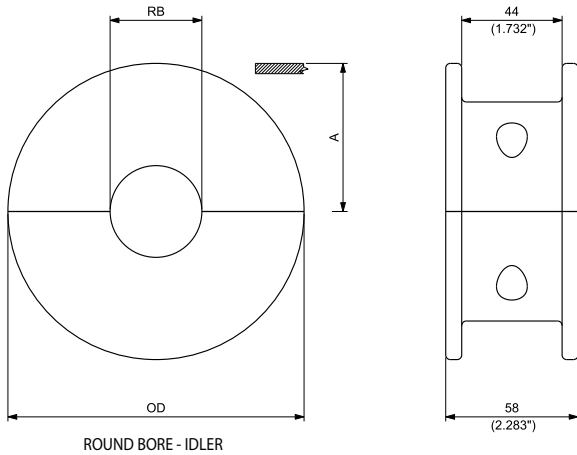

ROUND BORE - IDLER

## MACHINED SPLIT IDLER WHEELS

N. TEETH	OUTSIDE DIAMETER OD		WEAR STRIP POSITIONING A		BORE SIZE*		PART NUMBER ROUND BORE RB IDLER	WEIGHT	
	mm	inch	mm	inch	mm	inch		Kg	lbs
21	129,80	5.110	64,90	2.555	25		<b>CMAS048152125</b>	0,58	1.27
					30		<b>CMAS048152130</b>	0,56	1.24
					35		<b>CMAS048152135</b>	0,54	1.20
					40		<b>CMAS048152140</b>	0,52	1.15
					1		<b>CMAS0481521254</b>	0,58	1.27
					1 ¼		<b>CMAS0481521317</b>	0,56	1.24
					1 ⅞		<b>CMAS0481521365</b>	0,54	1.20
23	142,30	5.602	71,15	2.801	25		<b>CMAS048152325</b>	0,72	1.58
					30		<b>CMAS048152330</b>	0,70	1.55
					35		<b>CMAS048152335</b>	0,69	1.51
					40		<b>CMAS048152340</b>	0,67	1.47
					1		<b>CMAS0481523254</b>	0,72	1.58
					1 ¼		<b>CMAS0481523317</b>	0,70	1.55
					1 ⅞		<b>CMAS0481523365</b>	0,69	1.51
25	154,70	6.091	77,35	3.045	25		<b>CMAS048152525</b>	0,87	1.92
					30		<b>CMAS048152530</b>	0,85	1.88
					35		<b>CMAS048152535</b>	0,84	1.85
					40		<b>CMAS048152540</b>	0,82	1.80
					1		<b>CMAS0481525254</b>	0,87	1.91
					1 ¼		<b>CMAS0481525317</b>	0,85	1.88
					1 ⅞		<b>CMAS0481525365</b>	0,84	1.85
			1 ½		<b>CMAS0481525381</b>	0,83	1.82		

\*Diameter is indicated.



## SUITABLE FOR CHAINS:

- 2815
- PHDG 2815

### MATERIALS

SPROCKETS: **PGF** REINFORCED POLYAMIDE

SCREWS: **SS** STAINLESS STEEL

NUTS: **B+NC** NICKEL PLATED BRASS

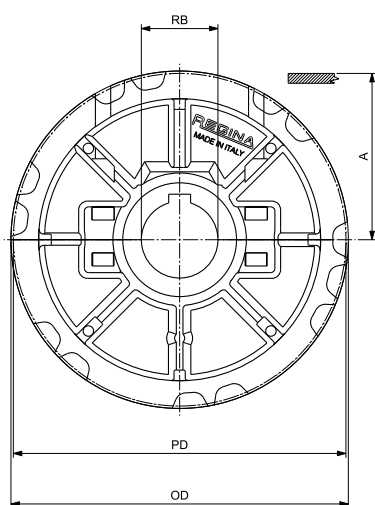

ROUND BORE - DRIVE

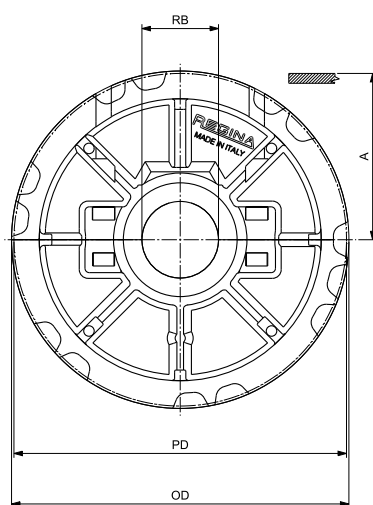

ROUND BORE - IDLER

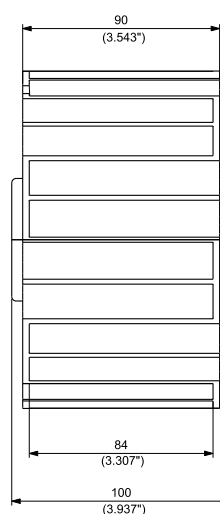

## MOULDED SPLIT DRIVE AND IDLER SPROCKETS

N. TEETH	PITCH DIAMETER PD		OUTSIDE DIAMETER OD		WEAR STRIP POSITIONING A		BORE SIZE*		PART NUMBER ROUND BORE RB		WEIGHT	
	mm	inch	mm	inch	mm	inch	mm	inch**	DRIVE	IDLER	Kg	lbs
25	153,20	6.031	154,20	6.071	80,00	3.150	30		<b>CMT022802502</b>	<b>CMT032802502</b>	1,05	2.30
							35		<b>CMT022802503</b>	<b>CMT032802503</b>	1,03	2.27
							40		<b>CMT022802504</b>	<b>CMT032802504</b>	1,01	2.22
							45		<b>CMT022802505</b>	<b>CMT032802505</b>	0,98	2.16
								1 ¼	<b>CMT022802508</b>	<b>CMT032802508</b>	1,04	2.29
								1 ⅜	<b>CMT022802511</b>	<b>CMT032802511</b>	1,03	2.27
								1 ⅞	<b>CMT022802509</b>	<b>CMT032802509</b>	1,02	2.25
	1 ½	<b>CMT022802510</b>	<b>CMT032802510</b>	1,01	2.24							

\*Diameter is indicated.

\*\* Imperial round bore drive sprockets are supplied with setscrew. Metric round bore drive sprockets are supplied without setscrew.

## SUITABLE FOR CHAINS:

- 2815
- PHDG 2815
- 821
- HFX 821
- LBP 821

## 19T, 21T & 23T SPROCKETS

(for 25T, 27T & 29T see next page)

MATERIALS	
SPROCKETS:	<b>PA</b> POLYAMIDE
SCREWS:	<b>SS</b> STAINLESS STEEL
NUTS:	<b>B</b> BRASS

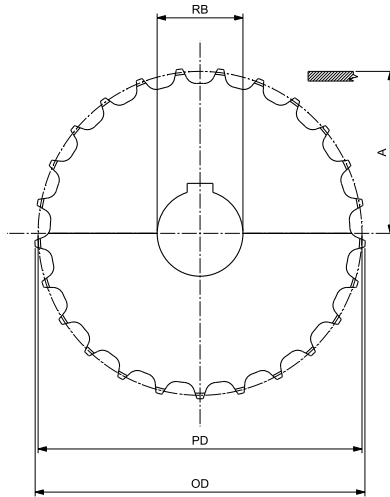
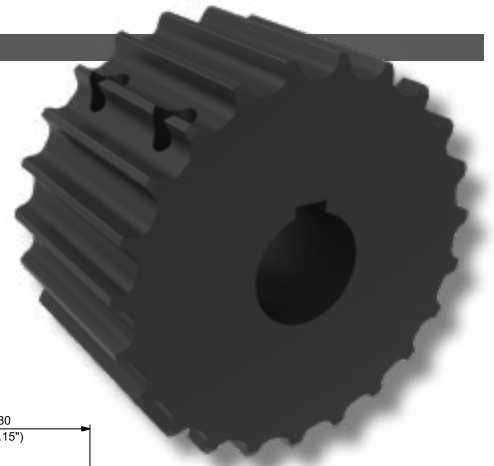

ROUND BORE - DRIVE

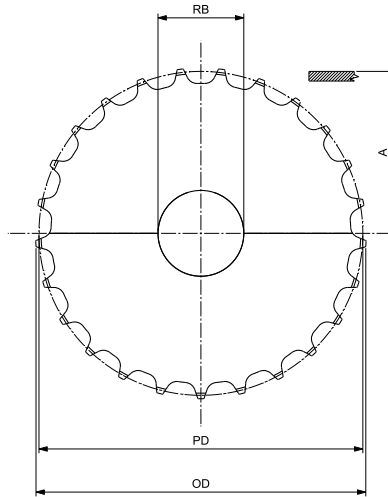

ROUND BORE - IDLER

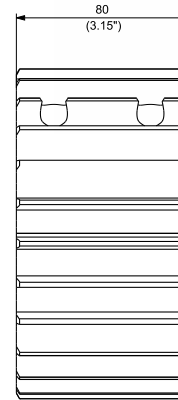

## MACHINED SPLIT DRIVE AND IDLER SPROCKETS

N. TEETH	PITCH DIAMETER PD		OUTSIDE DIAMETER OD		WEAR STRIP POSITIONING A		BORE SIZE*		PART NUMBER ROUND BORE RB		WEIGHT	
	mm	inch	mm	inch	mm	inch	mm	inch**	DRIVE	IDLER	Kg	lbs
19	117,34	4.620	117,00	4.606	62,27	2.452	25		<b>CMAS0228151925</b>	<b>CMAS0328151925</b>	0,87	1.92
							30		<b>CMAS0228151930</b>	<b>CMAS0328151930</b>	0,85	1.88
							35		<b>CMAS0228151935</b>	<b>CMAS0328151935</b>	0,83	1.83
							40		<b>CMAS0228151940</b>	<b>CMAS0328151940</b>	0,80	1.77
							1		<b>CMAS02281519254</b>	<b>CMAS03281519254</b>	0,87	1.92
							1 ¼		<b>CMAS02281519317</b>	<b>CMAS03281519317</b>	0,87	1.92
							1 ⅜		<b>CMAS02281519349</b>	<b>CMAS03281519349</b>	0,85	1.88
							1 ⅞		<b>CMAS02281519365</b>	<b>CMAS03281519365</b>	0,82	1.81
							1 ½		<b>CMAS02281519381</b>	<b>CMAS03281519381</b>	0,74	1.64
21	129,26	5.089	129,40	5.094	68,23	2.686	25		<b>CMAS0228152125</b>	<b>CMAS0328152125</b>	1,07	2.36
							30		<b>CMAS0228152130</b>	<b>CMAS0328152130</b>	1,04	2.29
							35		<b>CMAS0228152135</b>	<b>CMAS0328152135</b>	1,01	2.23
							40		<b>CMAS0228152140</b>	<b>CMAS0328152140</b>	0,99	2.17
							1		<b>CMAS02281521254</b>	<b>CMAS03281521254</b>	1,06	2.33
							1 ¼		<b>CMAS02281521317</b>	<b>CMAS03281521317</b>	1,06	2.33
							1 ⅜		<b>CMAS02281521349</b>	<b>CMAS03281521349</b>	1,04	2.29
							1 ⅞		<b>CMAS02281521365</b>	<b>CMAS03281521365</b>	0,99	2.17
							1 ½		<b>CMAS02281521381</b>	<b>CMAS03281521381</b>	1,00	2.20
23	141,22	5.560	141,90	5.587	74,21	2.922	25		<b>CMAS0228152325</b>	<b>CMAS0328152325</b>	1,27	2.81
							30		<b>CMAS0228152330</b>	<b>CMAS0328152330</b>	1,25	2.76
							35		<b>CMAS0228152335</b>	<b>CMAS0328152335</b>	1,23	2.71
							40		<b>CMAS0228152340</b>	<b>CMAS0328152340</b>	1,17	2.58
							1		<b>CMAS02281523254</b>	<b>CMAS03281523254</b>	1,27	2.80
							1 ¼		<b>CMAS02281523317</b>	<b>CMAS03281523317</b>	1,27	2.80
							1 ⅜		<b>CMAS02281523349</b>	<b>CMAS03281523349</b>	1,25	2.76
							1 ⅞		<b>CMAS02281523365</b>	<b>CMAS03281523365</b>	1,23	2.71
							1 ½		<b>CMAS02281523381</b>	<b>CMAS03281523381</b>	1,21	2.68

\*Diameter is indicated.

\*\* Imperial round bore drive sprockets are supplied with setscrew. Metric round bore drive sprockets are supplied without setscrew.

## SUITABLE FOR CHAINS:

- 2815
- PHDG 2815
- 821
- HFX 821
- LBP 821

### MATERIALS

SPROCKETS: **PA** POLYAMIDE

SCREWS: **SS** STAINLESS STEEL

NUTS: **B** BRASS

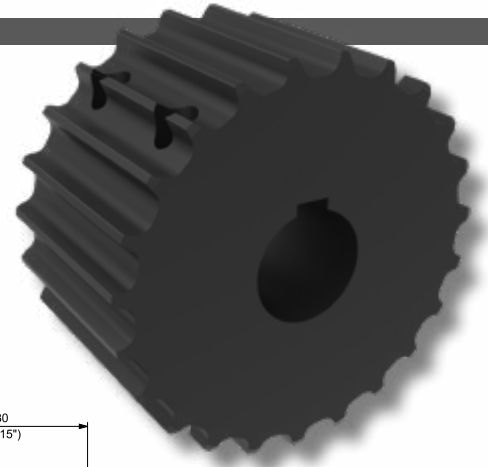

## 25T, 27T & 29T SPROCKETS

(for 19T, 21T & 23T see previous page)

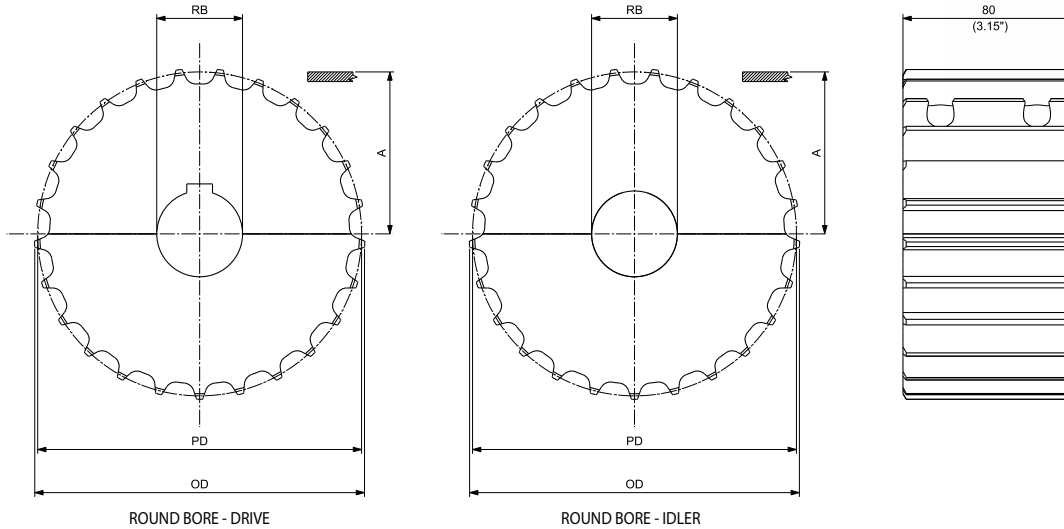

## MACHINED SPLIT DRIVE AND IDLER SPROCKETS

N. TEETH	PITCH DIAMETER PD		OUTSIDE DIAMETER OD		WEAR STRIP POSITIONING A		BORE SIZE*		PART NUMBER ROUND BORE RB		WEIGHT	
	mm	inch	mm	inch	mm	inch	mm	inch**	DRIVE	IDLER	Kg	lbs
25	153,20	6.031	154,20	6.071	80,20	3.157	25		<b>CMAS0228152525</b>	<b>CMAS0328152525</b>	1,56	3.45
							30		<b>CMAS0228152530</b>	<b>CMAS0328152530</b>	1,54	3.41
							35		<b>CMAS0228152535</b>	<b>CMAS0328152535</b>	1,52	3.36
							40		<b>CMAS0228152540</b>	<b>CMAS0328152540</b>	1,49	3.29
							1		<b>CMAS02281525254</b>	<b>CMAS03281525254</b>	1,56	3.45
							1 ¼		<b>CMAS02281525317</b>	<b>CMAS03281525317</b>	1,54	3.41
							1 ⅜		<b>CMAS02281525349</b>	<b>CMAS03281525349</b>	1,54	3.41
							1 ⅞		<b>CMAS02281525365</b>	<b>CMAS03281525365</b>	1,52	3.36
							1 ½		<b>CMAS02281525381</b>	<b>CMAS03281525381</b>	1,50	3.32
							27	165,21	6.504	166,40	6.551	86,21
30		<b>CMAS0228152730</b>	<b>CMAS0328152730</b>	1,80	3.96							
35		<b>CMAS0228152735</b>	<b>CMAS0328152735</b>	1,77	3.91							
40		<b>CMAS0228152740</b>	<b>CMAS0328152740</b>	1,75	3.85							
1		<b>CMAS02281527254</b>	<b>CMAS03281527254</b>	1,81	4.00							
1 ¼		<b>CMAS02281527317</b>	<b>CMAS03281527317</b>	1,81	4.00							
1 ⅜		<b>CMAS02281527349</b>	<b>CMAS03281527349</b>	1,80	3.96							
1 ⅞		<b>CMAS02281527365</b>	<b>CMAS03281527365</b>	1,77	3.91							
1 ½		<b>CMAS02281527381</b>	<b>CMAS03281527381</b>	1,76	3.48							
29	177,23	6.978	178,7	7.035	92,02	3.623						
							30		<b>CMAS0228152930</b>	<b>CMAS0328152930</b>	2,19	4.83
							35		<b>CMAS0228152935</b>	<b>CMAS0328152935</b>	2,17	4.78
							40		<b>CMAS0228152940</b>	<b>CMAS0328152940</b>	2,14	4.72
							1		<b>CMAS02281529254</b>	<b>CMAS03281529254</b>	2,20	4.85
							1 ¼		<b>CMAS02281529317</b>	<b>CMAS03281529317</b>	2,19	4.83
							1 ⅜		<b>CMAS02281529349</b>	<b>CMAS03281529349</b>	2,17	4.78
							1 ⅞		<b>CMAS02281529365</b>	<b>CMAS03281529365</b>	2,14	4.72
							1 ½		<b>CMAS02281529381</b>	<b>CMAS03281529381</b>	2,12	4.67

\*Diameter is indicated.

\*\*Imperial round bore drive sprockets are supplied with setscrew. Metric round bore drive sprockets are supplied without setscrew.

## SUITABLE FOR CHAINS:

- 2815
- PHDG 2815

### MATERIALS

SPROCKETS: **PA** POLYAMIDE

SCREWS: **SS** STAINLESS STEEL

NUTS: **B** BRASS

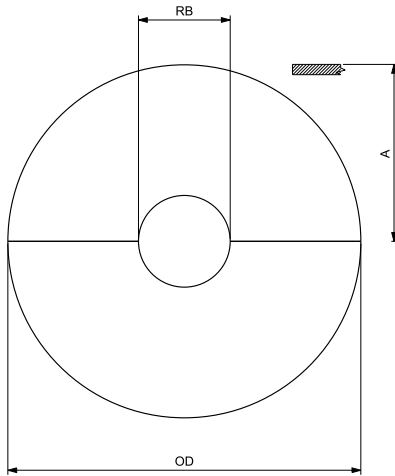

ROUND BORE - IDLER

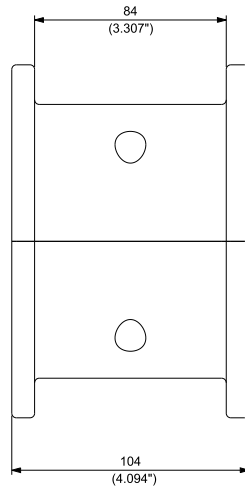

## MACHINED SPLIT IDLER WHEELS

N. TEETH	OUTSIDE DIAMETER OD		WEAR STRIP POSITIONING A		BORE SIZE*		PART NUMBER ROUND BORE RB IDLER	WEIGHT	
	mm	inch	mm	inch	mm	inch		Kg	lbs
19	118,00	4.646	59,00	2.323	25		<b>CMAS0428151925</b>	0,76	1.67
					30		<b>CMAS0428151930</b>	0,73	1.61
					35		<b>CMAS0428151935</b>	0,70	1.55
					40		<b>CMAS0428151940</b>	0,67	1.47
						1	<b>CMAS04281519254</b>	0,76	1.67
						1 ¼	<b>CMAS04281519317</b>	0,73	1.61
						1 ⅜	<b>CMAS04281519349</b>	0,70	1.55
21	129,80	5.110	64,90	2.555	25		<b>CMAS0428152125</b>	0,97	2.14
					30		<b>CMAS0428152130</b>	0,94	2.08
					35		<b>CMAS0428152135</b>	0,91	2.02
					40		<b>CMAS0428152140</b>	0,88	1.94
						1	<b>CMAS04281521254</b>	0,97	2.14
						1 ¼	<b>CMAS04281521317</b>	0,94	2.08
						1 ⅜	<b>CMAS04281521349</b>	0,91	2.02
23	142,30	5.602	71,15	2.801	25		<b>CMAS0428152325</b>	1,22	2.69
					30		<b>CMAS0428152330</b>	1,20	2.64
					35		<b>CMAS0428152335</b>	1,16	2.57
					40		<b>CMAS0428152340</b>	1,13	2.49
						1	<b>CMAS04281523254</b>	1,22	2.69
						1 ¼	<b>CMAS04281523317</b>	1,20	2.64
						1 ⅜	<b>CMAS04281523349</b>	1,16	2.57
25	154,70	6.091	77,35	3.045	25		<b>CMAS0428152525</b>	1,49	3.29
					30		<b>CMAS0428152530</b>	1,46	3.23
					35		<b>CMAS0428152535</b>	1,43	3.16
					40		<b>CMAS0428152540</b>	1,40	3.08
						1	<b>CMAS04281525254</b>	1,49	3.28
						1 ¼	<b>CMAS04281525317</b>	1,46	3.23
						1 ⅜	<b>CMAS04281525349</b>	1,43	3.16
	1 ½	<b>CMAS04281525381</b>	1,41	3.12					

\*Diameter is indicated.

## SUITABLE FOR CHAINS:

- PHD 9157
- PHDG 9157
- PHD 9857M
- PHDG 9857M

MATERIALS	
SPROCKETS:	<b>PA</b> POLYAMIDE
SCREWS:	<b>SS</b> STAINLESS STEEL
NUTS:	<b>B</b> BRASS



## 19T, 21T & 23T SPROCKETS

(for 25T & 27T see next page)

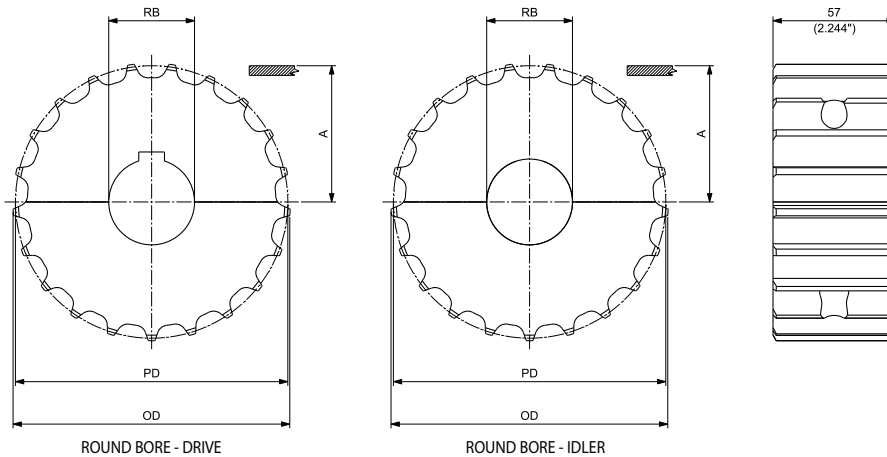

**MACHINED SPLIT IDLER WHEELS**  
SEE PAGE 139

## MACHINED SPLIT DRIVE AND IDLER SPROCKETS

N. TEETH	PITCH DIAMETER PD		OUTSIDE DIAMETER OD		WEAR STRIP POSITIONING A		BORE SIZE*		PART NUMBER ROUND BORE RB		WEIGHT	
	mm	inch	mm	inch	mm	inch	mm	inch**	DRIVE	IDLER	Kg	lbs
19	117,34	4.620	117,00	4.606	62,07	2.444	25		<b>CMAS0291571925</b>	<b>CMAS0391571925</b>	0,68	1.50
							30		<b>CMAS0291571930</b>	<b>CMAS0391571930</b>	0,66	1.46
							35		<b>CMAS0291571935</b>	<b>CMAS0391571935</b>	0,64	1.41
							40		<b>CMAS0291571940</b>	<b>CMAS0391571940</b>	0,63	1.39
							1		<b>CMAS02915719254</b>	<b>CMAS03915719254</b>	0,68	1.50
							1 ¼		<b>CMAS02915719317</b>	<b>CMAS03915719317</b>	0,67	1.48
							1 ⅜		<b>CMAS02915719349</b>	<b>CMAS03915719349</b>	0,66	1.46
21	129,26	5.089	129,40	5.094	68,03	2.678	25		<b>CMAS0291572125</b>	<b>CMAS0391572125</b>	0,74	1.64
							30		<b>CMAS0291572130</b>	<b>CMAS0391572130</b>	0,73	1.60
							35		<b>CMAS0291572135</b>	<b>CMAS0391572135</b>	0,71	1.57
							40		<b>CMAS0291572140</b>	<b>CMAS0391572140</b>	0,69	1.53
							1		<b>CMAS02915721254</b>	<b>CMAS03915721254</b>	0,74	1.63
							1 ¼		<b>CMAS02915721317</b>	<b>CMAS03915721381</b>	0,73	1.60
							1 ⅜		<b>CMAS02915721349</b>	<b>CMAS03915721349</b>	0,73	1.60
23	141,22	5.560	141,90	5.587	74,01	2.914	25		<b>CMAS0291572325</b>	<b>CMAS0391572325</b>	0,99	2.18
							30		<b>CMAS0291572330</b>	<b>CMAS0391572330</b>	0,98	2.16
							35		<b>CMAS0291572335</b>	<b>CMAS0391572335</b>	0,96	2.12
							40		<b>CMAS0291572340</b>	<b>CMAS0391572340</b>	0,94	2.07
							1		<b>CMAS02915723254</b>	<b>CMAS03915723254</b>	0,99	2.18
							1 ¼		<b>CMAS02915723317</b>	<b>CMAS03915723317</b>	0,99	2.18
							1 ⅜		<b>CMAS02915723349</b>	<b>CMAS03915723349</b>	0,98	2.16
1 ⅞		<b>CMAS02915723365</b>	<b>CMAS03915723365</b>	0,96	2.12							
1 ½		<b>CMAS02915723381</b>	<b>CMAS03915723381</b>	0,94	2.07							

\*Diameter is indicated.

\*\*Imperial round bore drive sprockets are supplied with setscrew. Metric round bore drive sprockets are supplied without setscrew.

## SUITABLE FOR CHAINS:

- PHD 9157
- PHDG 9157
- PHD 9857M
- PHDG 9857M

## MATERIALS

SPROCKETS: **PA** POLYAMIDE

SCREWS: **SS** STAINLESS STEEL

NUTS: **B** BRASS



## 25T & 27T SPROCKETS

(for 19T, 21T & 23T see previous page)

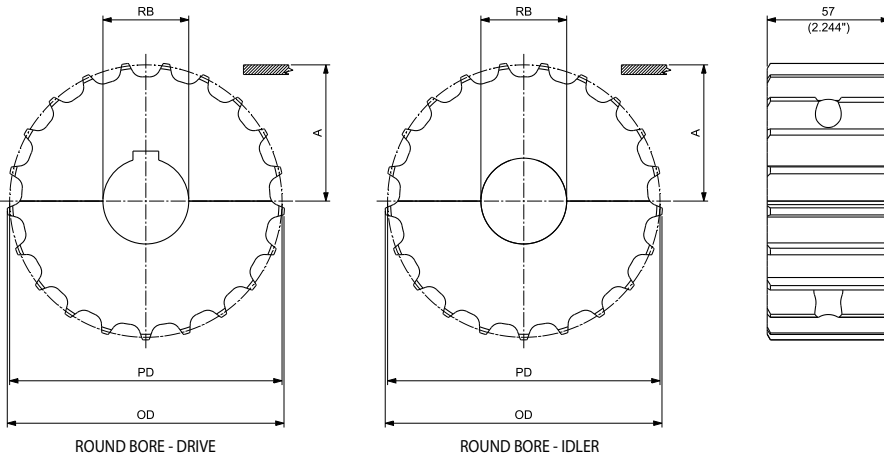

**MACHINED SPLIT IDLER WHEELS**  
SEE PAGE 139

## MACHINED SPLIT DRIVE AND IDLER SPROCKETS

N. TEETH	PITCH DIAMETER PD		OUTSIDE DIAMETER OD		WEAR STRIP POSITIONING A		BORE SIZE*		PART NUMBER ROUND BORE RB		WEIGHT	
	mm	inch	mm	inch	mm	inch	mm	inch**	DRIVE	IDLER	Kg	lbs
25	153,20	6.031	154,20	6.071	80,00	3.150		1	CMAS0291572525	CMAS0391572525	1,09	2.40
									CMAS0291572530	CMAS0391572530	1,07	2.37
									CMAS0291572535	CMAS0391572535	1,06	2.33
									CMAS0291572540	CMAS0391572540	1,04	2.29
									CMAS02915725254	CMAS03915725254	1,09	2.40
									CMAS02915725317	CMAS03915725317	1,09	2.40
									CMAS02915725349	CMAS03915725349	1,07	2.37
									CMAS02915725365	CMAS03915725365	1,06	2.33
									CMAS02915725381	CMAS03915725381	1,05	2.31
									CMAS0291572725	CMAS0391572725	1,27	2.80
27	165,21	6.504	166,40	6,551	86,01	3.386		1	CMAS0291572730	CMAS0391572730	1,26	2.77
									CMAS0291572735	CMAS0391572735	1,24	2.74
									CMAS0291572740	CMAS0391572740	1,22	2.69
									CMAS02915727254	CMAS03915727254	1,27	2.80
									CMAS02915727317	CMAS03915727317	1,27	2.80
									CMAS02915727349	CMAS03915727349	1,26	2.77
									CMAS02915727365	CMAS03915727365	1,24	2.74
									CMAS02915727381	CMAS03915727381	1,23	2.71

\*Diameter is indicated.

\*\* Imperial round bore drive sprockets are supplied with setscrew. Metric round bore drive sprockets are supplied without setscrew.



## SUITABLE FOR CHAINS:

• 803

### MATERIALS

SPROCKETS: **PA** POLYAMIDE

SCREWS: **SS** STAINLESS STEEL

NUTS: **B** BRASS

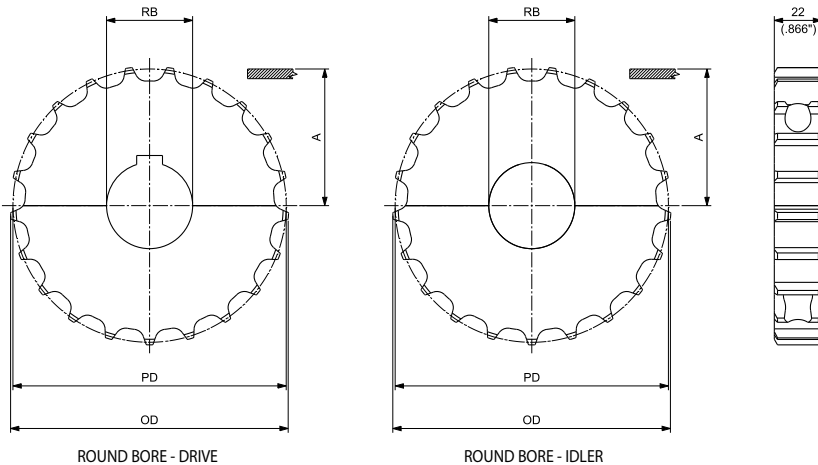

**MOULDED SPLIT SPROCKETS**  
SEE PAGE 135

## MACHINED SPLIT DRIVE AND IDLER SPROCKETS

N. TEETH	PITCH DIAMETER PD		OUTSIDE DIAMETER OD		WEAR STRIP POSITIONING A		BORE SIZE*		PART NUMBER ROUND BORE RB		WEIGHT	
	mm	inch	mm	inch	mm	inch	mm	inch**	DRIVE	IDLER	Kg	lbs
17	105,47	4.152	104,40	4.110	55,94	2.202	25		<b>CMAS028031725</b>	<b>CMAS038031725</b>	0,21	0.47
							30		<b>CMAS028031730</b>	<b>CMAS038031730</b>	0,20	0.45
							35		<b>CMAS028031735</b>	<b>CMAS038031735</b>	0,20	0.43
							40		<b>CMAS028031740</b>	<b>CMAS038031740</b>	0,20	0.45
							1		<b>CMAS0280317254</b>	<b>CMAS0380317254</b>	0,21	0.46
							1 ¼		<b>CMAS0280317317</b>	<b>CMAS0380317317</b>	0,20	0.44
19	117,34	4.620	117,00	4.606	62,87	2.475	25		<b>CMAS028031925</b>	<b>CMAS038031925</b>	0,26	0.57
							30		<b>CMAS028031930</b>	<b>CMAS038031930</b>	0,25	0.56
							35		<b>CMAS028031935</b>	<b>CMAS038031935</b>	0,25	0.54
							40		<b>CMAS028031940</b>	<b>CMAS038031940</b>	0,24	0.52
							1		<b>CMAS0280319254</b>	<b>CMAS0380319254</b>	0,26	0.57
							1 ¼		<b>CMAS0280319317</b>	<b>CMAS0380319317</b>	0,24	0.54
21	129,26	5.089	129,40	5.094	67,83	2.670	25		<b>CMAS028032125</b>	<b>CMAS038032125</b>	0,31	0.68
							30		<b>CMAS028032130</b>	<b>CMAS038032130</b>	0,30	0.67
							35		<b>CMAS028032135</b>	<b>CMAS038032135</b>	0,30	0.65
							40		<b>CMAS028032140</b>	<b>CMAS038032140</b>	0,29	0.63
							1		<b>CMAS0280321254</b>	<b>CMAS0380321254</b>	0,31	0.68
							1 ¼		<b>CMAS0280321317</b>	<b>CMAS0380321317</b>	0,29	0.64
23	141,22	5.560	141,90	5.587	73,81	2.906	25		<b>CMAS028032325</b>	<b>CMAS038032325</b>	0,37	0.80
							30		<b>CMAS028032330</b>	<b>CMAS038032330</b>	0,36	0.79
							35		<b>CMAS028032335</b>	<b>CMAS038032335</b>	0,35	0.78
							40		<b>CMAS028032340</b>	<b>CMAS038032340</b>	0,35	0.78
							1		<b>CMAS0280323254</b>	<b>CMAS0380323254</b>	0,36	0.80
							1 ¼		<b>CMAS0280323317</b>	<b>CMAS0380323317</b>	0,35	0.77
25	153,19	6.031	154,20	6.071	79,80	3.142	25		<b>CMAS028032525</b>	<b>CMAS038032525</b>	0,45	1.00
							30		<b>CMAS028032530</b>	<b>CMAS038032530</b>	0,45	0.99
							35		<b>CMAS028032535</b>	<b>CMAS038032535</b>	0,44	0.97
							40		<b>CMAS028032540</b>	<b>CMAS038032540</b>	0,43	0.96
							1		<b>CMAS0280325254</b>	<b>CMAS0380325254</b>	0,45	1.00
							1 ¼		<b>CMAS0280325317</b>	<b>CMAS0380325317</b>	0,44	0.96
				1 ½		<b>CMAS0280325381</b>	<b>CMAS0380325381</b>	0,38	0.84			

\*Diameter is indicated.

\*\* Imperial round bore drive sprockets are supplied with setscrew. Metric round bore drive sprockets are supplied without setscrew.

## SUITABLE FOR CHAINS:

- 881 / 881T
- 981 / 981T
- PHDG 981T
- 982T
- 803

### MATERIALS

SPROCKETS: **PGF** REINFORCED POLYAMIDE

SCREWS: **SS** STAINLESS STEEL

NUTS: **B+NC** NICKEL PLATED BRASS



## 19T & 21T SPROCKETS (for 23T & 25T see next page)

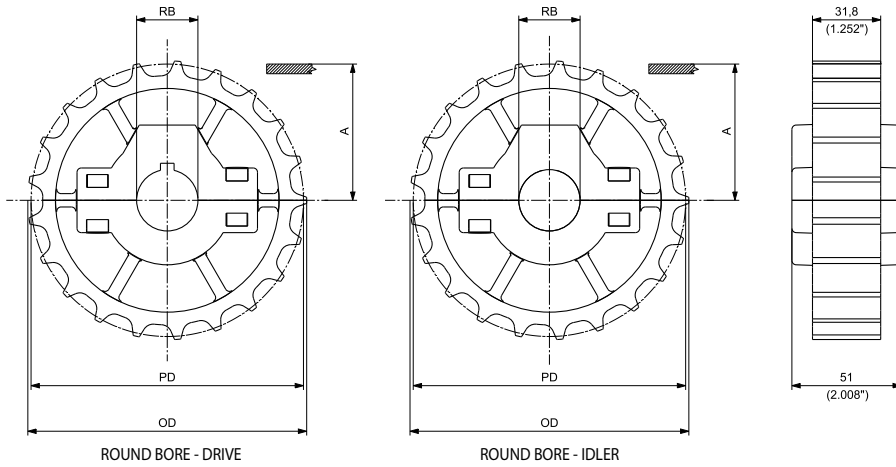

ROUND BORE - DRIVE

ROUND BORE - IDLER



**MOULDED SPLIT IDLER WHEELS FOR 881/981 CHAINS**  
SEE PAGE 125



**MOULDED SOLID IDLER WHEELS FOR 881/981 CHAINS**  
SEE PAGE 124

## MOULDED SPLIT DRIVE AND IDLER SPROCKETS

N. TEETH	PITCH DIAMETER PD		OUTSIDE DIAMETER OD		WEAR STRIP POSITIONING A		BORE SIZE*		PART NUMBER ROUND BORE RB		WEIGHT	
	mm	inch	mm	inch	mm	inch	mm	inch**	DRIVE	IDLER	Kg	lbs
19	117,34	4.620	117,00	4.606	62,07	2.444	25		CMT028811901	CMT038811901	0,33	0.73
							30		CMT028811902	CMT038811902	0,32	0.71
							35		CMT028811903	CMT038811903	0,31	0.68
							40		CMT028811904	CMT038811904	0,30	0.66
							45		CMT028811905	CMT038811905	0,29	0.64
								1	CMT028811906	CMT038811906	0,33	0.73
								1 ¼	CMT028811908	CMT038811908	0,32	0.71
								1 ⅜	CMT028811911	CMT038811911	0,32	0.71
								1 ⅞	CMT028811909	CMT038811909	0,31	0.68
								1 ½	CMT028811910	CMT038811910	0,31	0.68
21	129,30	5.091	130,00	5.118	68,05	2.679	25		CMT028812101	CMT038812101	0,43	0.95
							30		CMT028812102	CMT038812102	0,42	0.93
							35		CMT028812103	CMT038812103	0,41	0.91
							40		CMT028812104	CMT038812104	0,40	0.88
							45		CMT028812105	CMT038812105	0,39	0.85
								1	CMT028812106	CMT038812106	0,43	0.95
								1 ¼	CMT028812108	CMT038812108	0,42	0.92
								1 ⅜	CMT028812111	CMT038812111	0,42	0.92
								1 ⅞	CMT028812109	CMT038812109	0,41	0.90
								1 ½	CMT028812110	CMT038812110	0,40	0.89

\*Diameter is indicated.

\*\* Imperial round bore drive sprockets are supplied with setscrew. Metric round bore drive sprockets are supplied without setscrew.

## SUITABLE FOR CHAINS:

- 881 / 881T
- 981 / 981T
- PHDG 981T
- 982T
- 803

### MATERIALS

SPROCKETS: **PGF** REINFORCED POLYAMIDE

SCREWS: **SS** STAINLESS STEEL

NUTS: **B+NC** NICKEL PLATED BRASS



## 23T & 25T SPROCKETS

(for 19T & 21T see previous page)

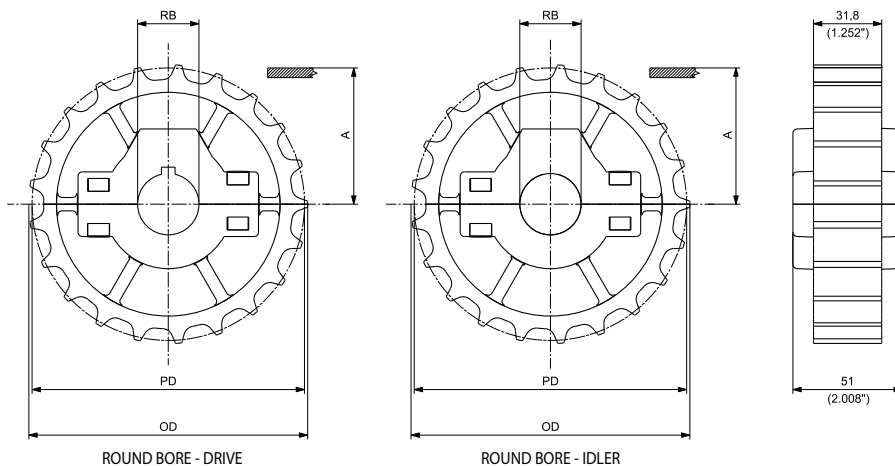

**MOULDED SPLIT IDLER WHEELS FOR 881/981 CHAINS**  
SEE PAGE 125



**MOULDED SOLID IDLER WHEELS FOR 881/981 CHAINS**  
SEE PAGE 124

## MOULDED SPLIT DRIVE AND IDLER SPROCKETS

N. TEETH	PITCH DIAMETER PD		OUTSIDE DIAMETER OD		WEAR STRIP POSITIONING A		BORE SIZE*		PART NUMBER ROUND BORE RB		WEIGHT	
	mm	inch	mm	inch	mm	inch	mm	inch**	DRIVE	IDLER	Kg	lbs
23	141,20	5.559	141,90	5.587	74,00	2.913	25		<b>CMT028812301</b>	<b>CMT038812301</b>	0,47	1.04
							30		<b>CMT028812302</b>	<b>CMT038812302</b>	0,46	1.02
							35		<b>CMT028812303</b>	<b>CMT038812303</b>	0,45	1.00
							40		<b>CMT028812304</b>	<b>CMT038812304</b>	0,44	0.97
							45		<b>CMT028812305</b>	<b>CMT038812305</b>	0,43	0.94
							1		<b>CMT028812306</b>	<b>CMT038812306</b>	0,47	1.04
							1 ¼		<b>CMT028812308</b>	<b>CMT038812308</b>	0,46	1.01
							1 ⅜		<b>CMT028812311</b>	<b>CMT038812311</b>	0,46	1.01
							1 ⅞		<b>CMT028812309</b>	<b>CMT038812309</b>	0,45	0.99
							1 ½		<b>CMT028812310</b>	<b>CMT038812310</b>	0,44	0.98
25	153,20	6.031	154,20	6.071	80,00	3.150	25		<b>CMT028812501</b>	<b>CMT038812501</b>	0,51	1.13
							30		<b>CMT028812502</b>	<b>CMT038812502</b>	0,50	1.11
							35		<b>CMT028812503</b>	<b>CMT038812503</b>	0,49	1.09
							40		<b>CMT028812504</b>	<b>CMT038812504</b>	0,48	1.06
							45		<b>CMT028812505</b>	<b>CMT038812505</b>	0,47	1.03
							1		<b>CMT028812506</b>	<b>CMT038812506</b>	0,51	1.13
							1 ¼		<b>CMT028812508</b>	<b>CMT038812508</b>	0,50	1.10
							1 ⅜		<b>CMT028812511</b>	<b>CMT038812511</b>	0,50	1.10
							1 ⅞		<b>CMT028812509</b>	<b>CMT038812509</b>	0,49	1.08
							1 ½		<b>CMT028812510</b>	<b>CMT038812510</b>	0,48	1.07

\*Diameter is indicated.

\*\* Imperial round bore drive sprockets are supplied with setscrew. Metric round bore drive sprockets are supplied without setscrew.

## SUITABLE FOR CHAINS:

- 881 / 881T
- 981 / 981T
- PHDG 981T
- 982T

## MATERIALS

SPROCKETS:	<b>PA</b>	POLYAMIDE
SCREWS:	<b>SS</b>	STAINLESS STEEL
NUTS:	<b>B</b>	BRASS



## 17T, 19T & 21T SPROCKETS

(for 23T, 25T & 27T see next page)

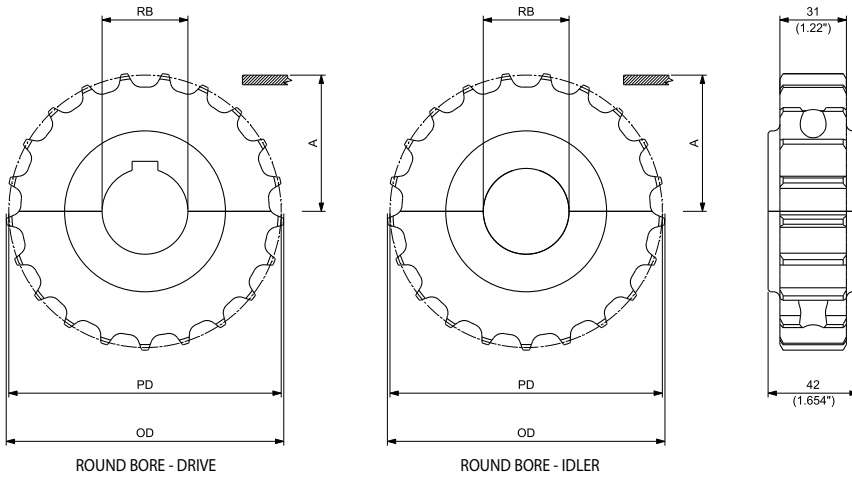

**MACHINED SPLIT IDLER WHEELS FOR 881/981 CHAINS**  
SEE PAGE 126

## MACHINED SPLIT DRIVE AND IDLER SPROCKETS

N. TEETH	PITCH DIAMETER PD		OUTSIDE DIAMETER OD		WEAR STRIP POSITIONING A		BORE SIZE*		PART NUMBER ROUND BORE RB		WEIGHT	
	mm	inch	mm	inch	mm	inch	mm	inch**	DRIVE	IDLER	Kg	lbs
17	105,47	4.152	104,40	4.110	56,14	2.210	25		<b>CMAS028811725</b>	<b>CMAS038811725</b>	0,31	0.68
							30		<b>CMAS028811730</b>	<b>CMAS038811730</b>	0,30	0.66
							35		<b>CMAS028811735</b>	<b>CMAS038811735</b>	0,29	0.63
							40		<b>CMAS028811740</b>	<b>CMAS038811740</b>	0,27	0.60
							1		<b>CMAS0288117254</b>	<b>CMAS0388117254</b>	0,31	0.68
							1 ¼		<b>CMAS0288117317</b>	<b>CMAS0388117317</b>	0,29	0.65
							1 ⅜		<b>CMAS0288117349</b>	<b>CMAS0388117349</b>	0,29	0.65
							1 ⅞		<b>CMAS0288117365</b>	<b>CMAS0388117365</b>	0,28	0.61
							1 ½		<b>CMAS0288117381</b>	<b>CMAS0388117381</b>	0,28	0.61
							19	117,34	4.620	117,00	4.606	62,07
30		<b>CMAS028811930</b>	<b>CMAS038811930</b>	0,38	0.84							
35		<b>CMAS028811935</b>	<b>CMAS038811935</b>	0,37	0.81							
40		<b>CMAS028811940</b>	<b>CMAS038811940</b>	0,35	0.78							
1		<b>CMAS0288119254</b>	<b>CMAS0388119254</b>	0,39	0.86							
1 ¼		<b>CMAS0288119317</b>	<b>CMAS0388119317</b>	0,38	0.84							
1 ⅜		<b>CMAS0288119349</b>	<b>CMAS0388119349</b>	0,37	0.81							
1 ⅞		<b>CMAS0288119365</b>	<b>CMAS0388119365</b>	0,36	0.80							
1 ½		<b>CMAS0288119381</b>	<b>CMAS0388119381</b>	0,32	0.71							
21	129,26	5.089	129,40	5.094	68,03	2.678						
							30		<b>CMAS028812130</b>	<b>CMAS038812130</b>	0,46	1.01
							35		<b>CMAS028812135</b>	<b>CMAS038812135</b>	0,45	0.98
							40		<b>CMAS028812140</b>	<b>CMAS038812140</b>	0,43	0.95
							1		<b>CMAS0288121254</b>	<b>CMAS0388121254</b>	0,47	1.03
							1 ¼		<b>CMAS0288121317</b>	<b>CMAS0388121317</b>	0,47	1.03
							1 ⅜		<b>CMAS0288121349</b>	<b>CMAS0388121349</b>	0,46	1.01
							1 ⅞		<b>CMAS0288121365</b>	<b>CMAS0388121365</b>	0,45	0.98
							1 ½		<b>CMAS0288121381</b>	<b>CMAS0388121381</b>	0,44	0.96

\*Diameter is indicated.

\*\* Imperial round bore drive sprockets are supplied with setscrew. Metric round bore drive sprockets are supplied without setscrew.

## SUITABLE FOR CHAINS:

- 881 / 881T
- 981 / 981T
- PHDG 981T
- 982T

## MATERIALS

SPROCKETS: **PA** POLYAMIDE  
 SCREWS: **SS** STAINLESS STEEL  
 NUTS: **B** BRASS



## 23T, 25T & 27T SPROCKETS

(for 17T, 19T & 21T see previous page)

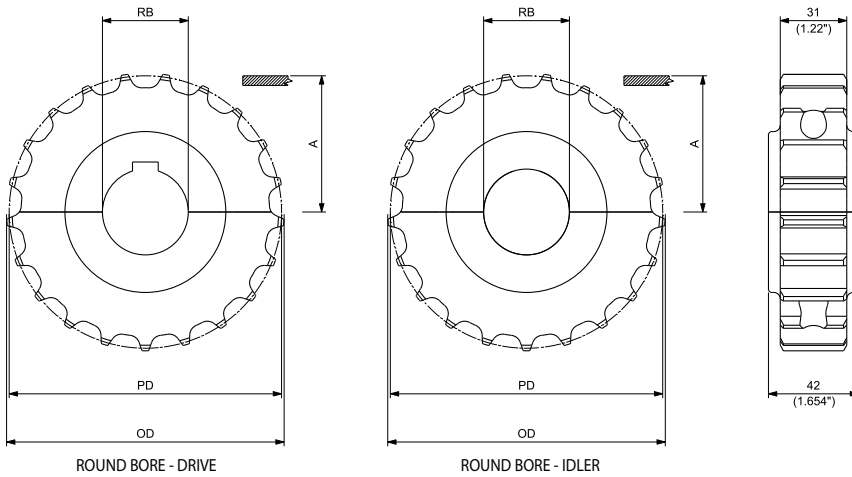

**MACHINED SPLIT  
 IDLER WHEELS  
 FOR 881/981 CHAINS**  
 SEE PAGE 126

## MACHINED SPLIT DRIVE AND IDLER SPROCKETS

N. TEETH	PITCH DIAMETER PD		OUTSIDE DIAMETER OD		WEAR STRIP POSITIONING A		BORE SIZE*		PART NUMBER ROUND BORE RB		WEIGHT	
	mm	inch	mm	inch	mm	inch	mm	inch**	DRIVE	IDLER	Kg	lbs
23	141,22	5.560	141,90	5.587	74,01	2.914	25		<b>CMAS028812325</b>	<b>CMAS038812325</b>	0,56	1.23
							30		<b>CMAS028812330</b>	<b>CMAS038812330</b>	0,55	1.21
							35		<b>CMAS028812335</b>	<b>CMAS038812335</b>	0,54	1.18
							40		<b>CMAS028812340</b>	<b>CMAS038812340</b>	0,52	1.15
							1		<b>CMAS0288123254</b>	<b>CMAS0388123254</b>	0,56	1.23
							1 ¼		<b>CMAS0288123317</b>	<b>CMAS0388123317</b>	0,56	1.23
							1 ⅜		<b>CMAS0288123349</b>	<b>CMAS0388123349</b>	0,55	1.21
25	153,20	6.031	154,20	6.071	80,00	3.150	25		<b>CMAS028812525</b>	<b>CMAS038812525</b>	0,69	1.52
							30		<b>CMAS028812530</b>	<b>CMAS038812530</b>	0,68	1.50
							35		<b>CMAS028812535</b>	<b>CMAS038812535</b>	0,67	1.47
							40		<b>CMAS028812540</b>	<b>CMAS038812540</b>	0,65	1.44
							1		<b>CMAS0288125254</b>	<b>CMAS0388125254</b>	0,69	1.52
							1 ¼		<b>CMAS0288125317</b>	<b>CMAS0388125317</b>	0,69	1.52
							1 ⅜		<b>CMAS0288125349</b>	<b>CMAS0388125349</b>	0,68	1.50
27	165,21	6.504	166,40	6.551	86,01	3.386	25		<b>CMAS028812725</b>	<b>CMAS038812725</b>	0,83	1.84
							30		<b>CMAS028812730</b>	<b>CMAS038812730</b>	0,82	1.81
							35		<b>CMAS028812735</b>	<b>CMAS038812735</b>	0,81	1.79
							40		<b>CMAS028812740</b>	<b>CMAS038812740</b>	0,80	1.75
							1		<b>CMAS0288127254</b>	<b>CMAS0388127254</b>	0,83	1.83
							1 ¼		<b>CMAS0288127317</b>	<b>CMAS0388127317</b>	0,83	1.83
							1 ⅜		<b>CMAS0288127349</b>	<b>CMAS0388127349</b>	0,82	1.81
		<b>CMAS0288127365</b>	<b>CMAS0388127365</b>	0,81	1.79							
		<b>CMAS0288127381</b>	<b>CMAS0388127381</b>	0,80	1.76							

\*Diameter is indicated.

\*\* Imperial round bore drive sprockets are supplied with setscrew. Metric round bore drive sprockets are supplied without setscrew.

## SUITABLE FOR CHAINS:

- PHD 9157
- PHDG 9157
- 881T
- 981T
- PHDG 981T
- PHD 9857M
- PHDG 9857M
- 982T

## MATERIALS

SPROCKETS: **PA** POLYAMIDE

SCREWS: **SS** STAINLESS STEEL

NUTS: **B** BRASS



## 17T,19T & 21T IDLER WHEELS

(for 23T & 25T see next page)

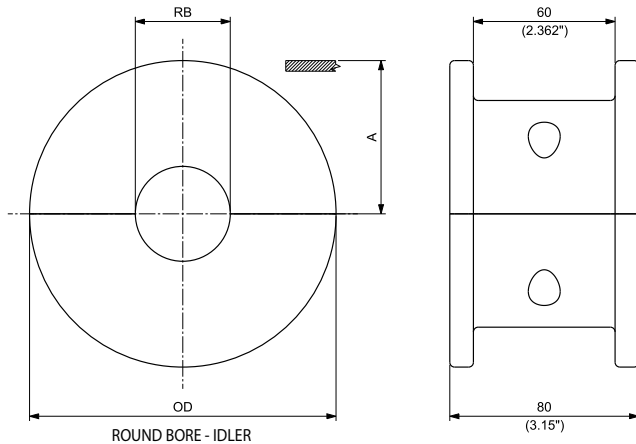

## MACHINED SPLIT IDLER WHEELS

N. TEETH	OUTSIDE DIAMETER OD		WEAR STRIP POSITIONING A		BORE SIZE*		PART NUMBER ROUND BORE RB IDLER	WEIGHT	
	mm	inch	mm	inch	mm	inch		Kg	lbs
17	106,50	4.193	53,25	2.096	25		<b>CMAS04881T1725</b>	0,44	0,97
					25		<b>CMAS04881T1730</b>	0,42	0,93
					35		<b>CMAS04881T1735</b>	0,39	0,86
					40		<b>CMAS04881T1740</b>	0,37	0,82
					1		<b>CMAS04881T17254</b>	0,44	0,97
					1 ¼		<b>CMAS04881T17317</b>	0,42	0,93
					1 ⅜		<b>CMAS04881T17349</b>	0,42	0,93
					1 ⅞		<b>CMAS04881T17365</b>	0,39	0,86
19	118,00	4.646	59,00	2.323	25		<b>CMAS04881T1925</b>	0,58	1,28
					30		<b>CMAS04881T1930</b>	0,56	1,23
					35		<b>CMAS04881T1935</b>	0,54	1,19
					40		<b>CMAS04881T1940</b>	0,51	1,12
					1		<b>CMAS04881T19254</b>	0,58	1,28
					1 ¼		<b>CMAS04881T19317</b>	0,58	1,28
					1 ⅜		<b>CMAS04881T19349</b>	0,56	1,23
					1 ⅞		<b>CMAS04881T19365</b>	0,54	1,19
21	129,80	5.110	64,90	2.555	25		<b>CMAS04881T2125</b>	0,79	1,73
					30		<b>CMAS04881T2130</b>	0,77	1,69
					35		<b>CMAS04881T2135</b>	0,74	1,64
					40		<b>CMAS04881T2140</b>	0,72	1,58
					1		<b>CMAS04881T21254</b>	0,78	1,73
					1 ¼		<b>CMAS04881T21317</b>	0,78	1,73
					1 ⅜		<b>CMAS04881T21349</b>	0,77	1,69
					1 ⅞		<b>CMAS04881T21365</b>	0,74	1,64
			1 ½		<b>CMAS04881T21381</b>	0,73	1,60		

\*Diameter is indicated.



## SUITABLE FOR CHAINS:

- PHD 9157
- PHDG 9157
- 881T
- 981T
- PHDG 981T
- PHD 9857M
- PHDG 9857M
- 982T

## MATERIALS

SPROCKETS:	<b>PA</b>	POLYAMIDE
SCREWS:	<b>SS</b>	STAINLESS STEEL
NUTS:	<b>B</b>	BRASS



## 23T & 25T IDLER WHEELS

(for 17T, 19T & 21T see previous page)

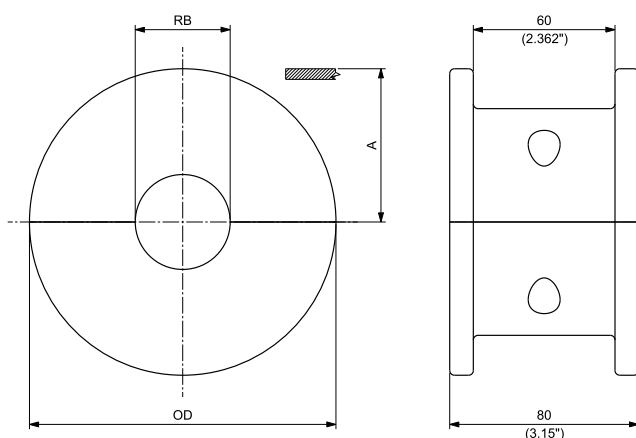

ROUND BORE - IDLER

## MACHINED SPLIT IDLER WHEELS

N. TEETH	OUTSIDE DIAMETER OD		WEAR STRIP POSITIONING A		BORE SIZE*		PART NUMBER ROUND BORE RB IDLER	WEIGHT	
	mm	inch	mm	inch	mm	inch		Kg	lbs
23	142,30	5.602	71,15	2.801	25		<b>CMAS04881T2325</b>	0,98	2.17
					30		<b>CMAS04881T2330</b>	0,96	2.13
					35		<b>CMAS04881T2335</b>	0,94	2.07
					40		<b>CMAS04881T2340</b>	0,91	2.01
					1		<b>CMAS04881T23254</b>	0,98	2.17
					1 ¼		<b>CMAS04881T23317</b>	0,98	2.17
					1 ⅜		<b>CMAS04881T23349</b>	0,96	2.13
					1 ⅞		<b>CMAS04881T23365</b>	0,94	2.07
					1 ½		<b>CMAS04881T23381</b>	0,92	2.04
					25	154,70	6.091	77,35	3.045
30		<b>CMAS04881T2530</b>	1,17	2.58					
35		<b>CMAS04881T2535</b>	1,15	2.53					
40		<b>CMAS04881T2540</b>	1,12	2.47					
1		<b>CMAS04881T25254</b>	1,19	2.62					
1 ¼		<b>CMAS04881T25317</b>	1,19	2.62					
1 ⅜		<b>CMAS04881T25349</b>	1,17	2.58					
1 ⅞		<b>CMAS04881T25365</b>	1,15	2.53					
1 ½		<b>CMAS04881T25381</b>	1,13	2.50					

\*Diameter is indicated.

## SUITABLE FOR CHAINS:

- 820
- HFX 820
- 831

## MATERIALS

SPROCKETS: **PGF** REINFORCED POLYAMIDE

SCREWS: **SS** STAINLESS STEEL

NUTS: **B+NC** NICKEL PLATED BRASS



## 19T & 21T SPROCKETS

(for 23T & 25T see next page)

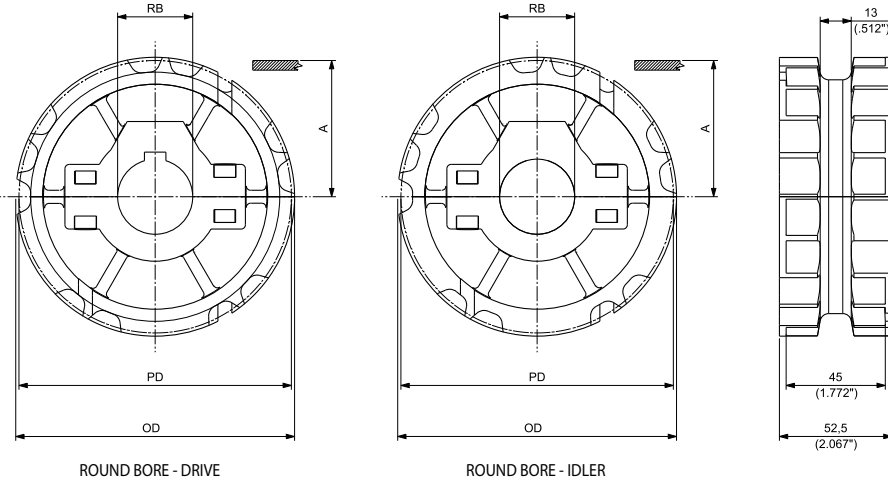

**MOULDED SPLIT IDLER WHEELS**  
SEE PAGE 125



**MOULDED SOLID IDLER WHEELS**  
SEE PAGE 124

## MOULDED SPLIT DRIVE AND IDLER SPROCKETS

N. TEETH	PITCH DIAMETER PD		OUTSIDE DIAMETER OD		WEAR STRIP POSITIONING A		BORE SIZE*		PART NUMBER ROUND BORE RB		WEIGHT	
	mm	inch	mm	inch	mm	inch	mm	inch**	DRIVE	IDLER	Kg	lbs
							25		<b>CMT028201901</b>	<b>CMT038201901</b>	0,36	0.79
							30		<b>CMT028201902</b>	<b>CMT038201902</b>	0,35	0.77
							35		<b>CMT028201903</b>	<b>CMT038201903</b>	0,34	0.75
							40		<b>CMT028201904</b>	<b>CMT038201904</b>	0,33	0.73
							45		<b>CMT028201905</b>	<b>CMT038201905</b>	0,22	0.49
							1		<b>CMT028201906</b>	<b>CMT038201906</b>	0,36	0.79
							1 ¼		<b>CMT028201908</b>	<b>CMT038201908</b>	0,35	0.77
							1 ⅜		<b>CMT028201911</b>	<b>CMT038201911</b>	0,35	0.77
							1 7/16		<b>CMT028201909</b>	<b>CMT038201909</b>	0,34	0.75
							1 ½		<b>CMT028201910</b>	<b>CMT038201910</b>	0,33	0.73
							25		<b>CMT028202101</b>	<b>CMT038202101</b>	0,48	1.05
							30		<b>CMT028202102</b>	<b>CMT038202102</b>	0,47	1.03
							35		<b>CMT028202103</b>	<b>CMT038202103</b>	0,46	1.01
							40		<b>CMT028202104</b>	<b>CMT038202104</b>	0,45	0.98
							45		<b>CMT028202105</b>	<b>CMT038202105</b>	0,43	0.95
							1		<b>CMT028202106</b>	<b>CMT038202106</b>	0,48	1.05
							1 ¼		<b>CMT028202108</b>	<b>CMT038202108</b>	0,46	1.02
							1 ⅜		<b>CMT028202111</b>	<b>CMT038202111</b>	0,46	1.02
							1 7/16		<b>CMT028202109</b>	<b>CMT038202109</b>	0,45	1.00
							1 ½		<b>CMT028202110</b>	<b>CMT038202110</b>	0,45	0.99

\*Diameter is indicated.

\*\* Imperial round bore drive sprockets are supplied with setscrew. Metric round bore drive sprockets are supplied without setscrew.

## SUITABLE FOR CHAINS:

- 820
- HFX 820
- 831

## MATERIALS

SPROCKETS: **PGF** REINFORCED POLYAMIDE

SCREWS: **SS** STAINLESS STEEL

NUTS: **B+NC** NICKEL PLATED BRASS



## 23T & 25T SPROCKETS

(for 19T & 21T see previous page)

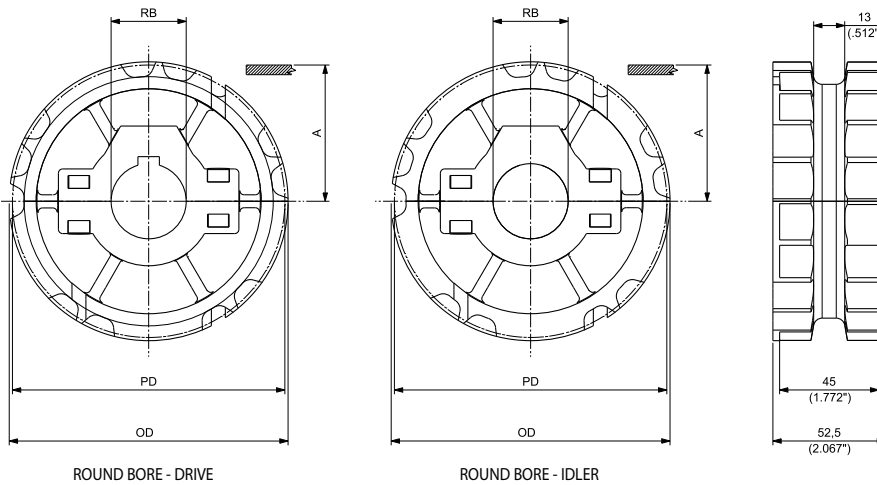

ROUND BORE - DRIVE

ROUND BORE - IDLER



**MOULDED SPLIT IDLER WHEELS**  
SEE PAGE 125



**MOULDED SOLID IDLER WHEELS**  
SEE PAGE 124

## MOULDED SPLIT DRIVE AND IDLER SPROCKETS

N. TEETH	PITCH DIAMETER PD		OUTSIDE DIAMETER OD		WEAR STRIP POSITIONING A		BORE SIZE*		PART NUMBER ROUND BORE RB		WEIGHT	
	mm	inch	mm	inch	mm	inch	mm	inch**	DRIVE	IDLER	Kg	lbs
23	141,20	5.559	141,90	5.587	74,00	2.913	25		<b>CMT028202301</b>	<b>CMT038202301</b>	0,52	1.15
							30		<b>CMT028202302</b>	<b>CMT038202302</b>	0,51	1.13
							35		<b>CMT028202303</b>	<b>CMT038202303</b>	0,50	1.11
							40		<b>CMT028202304</b>	<b>CMT038202304</b>	0,49	1.08
							45		<b>CMT028202305</b>	<b>CMT038202305</b>	0,48	1.05
							1		<b>CMT028202306</b>	<b>CMT038202306</b>	0,52	1.15
							1 ¼		<b>CMT028202308</b>	<b>CMT038202308</b>	0,51	1.13
							1 ⅜		<b>CMT028202311</b>	<b>CMT038202311</b>	0,51	1.13
							1 ⅞		<b>CMT028202309</b>	<b>CMT038202309</b>	0,50	1.10
							1 ½		<b>CMT028202310</b>	<b>CMT038202310</b>	0,50	1.09
25	153,20	6.031	154,20	6.071	80,00	3.150	25		<b>CMT028202501</b>	<b>CMT038202501</b>	0,57	1.26
							30		<b>CMT028202502</b>	<b>CMT038202502</b>	0,56	1.24
							35		<b>CMT028202503</b>	<b>CMT038202503</b>	0,55	1.22
							40		<b>CMT028202504</b>	<b>CMT038202504</b>	0,54	1.19
							45		<b>CMT028202505</b>	<b>CMT038202505</b>	0,53	1.16
							1		<b>CMT028202506</b>	<b>CMT038202506</b>	0,57	1.26
							1 ¼		<b>CMT028202508</b>	<b>CMT038202508</b>	0,56	1.23
							1 ⅜		<b>CMT028202511</b>	<b>CMT038202511</b>	0,56	1.23
							1 ⅞		<b>CMT028202509</b>	<b>CMT038202509</b>	0,55	1.21
							1 ½		<b>CMT028202510</b>	<b>CMT038202510</b>	0,55	1.20

\*Diameter is indicated.

\*\* Imperial round bore drive sprockets are supplied with setscrew. Metric round bore drive sprockets are supplied without setscrew.

## SUITABLE FOR CHAINS:

- 820
- HFX 820
- 831

**17T, 19T & 21T SPROCKETS**  
(for 23T, 25T & 27T see next page)

MATERIALS	
SPROCKETS:	<b>PA</b> POLYAMIDE
SCREWS:	<b>SS</b> STAINLESS STEEL
NUTS:	<b>B</b> BRASS

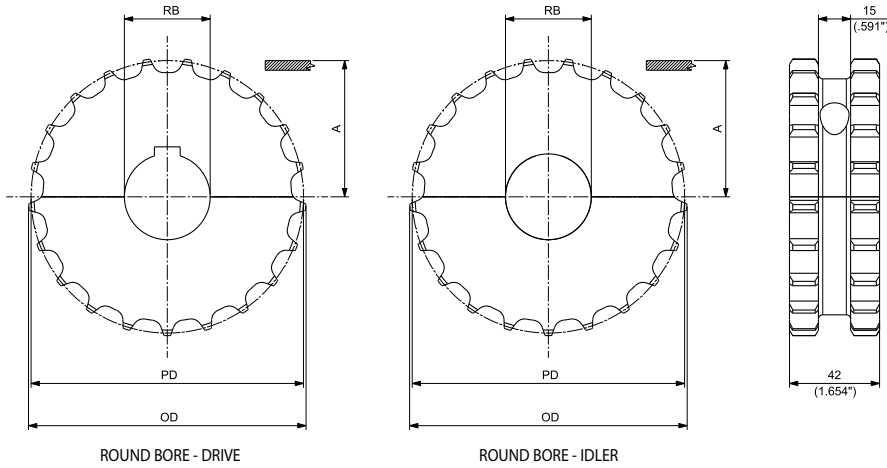

**MACHINED SPLIT IDLER WHEELS**  
SEE PAGE 126

## MACHINED SPLIT DRIVE AND IDLER SPROCKETS

N. TEETH	PITCH DIAMETER PD		OUTSIDE DIAMETER OD		WEAR STRIP POSITIONING A		BORE SIZE*		PART NUMBER ROUND BORE RB		WEIGHT		
	mm	inch	mm	inch	mm	inch	mm	inch**	DRIVE	IDLER	Kg	lbs	
17	105,47	4.152	104,40	4.110	55,94	2.202			25	CMAS028201725	CMAS038201725	0,34	0.75
									30	CMAS028201730	CMAS038201730	0,34	0.73
									35	CMAS028201735	CMAS038201735	0,32	0.70
									40	CMAS028201740	CMAS038201740	0,30	0.67
									1	CMAS0282017254	CMAS0382017254	0,34	0.75
									1 ¼	CMAS0282017317	CMAS0382017317	0,33	0.72
									1 ⅜	CMAS0282017349	CMAS0382017349	0,33	0.72
									1 ⅞	CMAS0282017365	CMAS0382017365	0,32	0.70
									1 ½	CMAS0282017381	CMAS0382017381	0,31	0.68
									19	117,34	4.620	117,00	4.606
30	CMAS028201930	CMAS038201930	0,42	0.92									
35	CMAS028201935	CMAS038201935	0,40	0.89									
40	CMAS028201940	CMAS038201940	0,39	0.86									
1	CMAS0282019254	CMAS0382019254	0,43	0.94									
1 ¼	CMAS0282019317	CMAS0382019317	0,43	0.94									
1 ⅜	CMAS0282019349	CMAS0382019349	0,42	0.92									
1 ⅞	CMAS0282019365	CMAS0382019365	0,40	0.88									
1 ½	CMAS0282019381	CMAS0382019381	0,36	0.79									
21	129,26	5.089	129,40	5.094	68,83	2.710							
									30	CMAS028202130	CMAS038202130	0,52	1.14
									35	CMAS028202135	CMAS038202135	0,51	1.11
									40	CMAS028202140	CMAS038202140	0,49	1.08
									1	CMAS0282021254	CMAS0382021254	0,53	1.16
									1 ¼	CMAS0282021317	CMAS0382021317	0,53	1.16
									1 ⅜	CMAS0282021349	CMAS0382021349	0,52	1.14
									1 ⅞	CMAS0282021365	CMAS0382021365	0,51	1.11
									1 ½	CMAS0282021381	CMAS0382021381	0,50	1.10

\*Diameter is indicated.

\*\* Imperial round bore drive sprockets are supplied with setscrew. Metric round bore drive sprockets are supplied without setscrew.

## SUITABLE FOR CHAINS:

- 820
- HFX 820
- 831

## MATERIALS

SPROCKETS: **PA** POLYAMIDE

SCREWS: **SS** STAINLESS STEEL

NUTS: **B** BRASS

## 23T, 25T & 27T SPROCKETS

(for 17T, 19T & 21T see previous page)

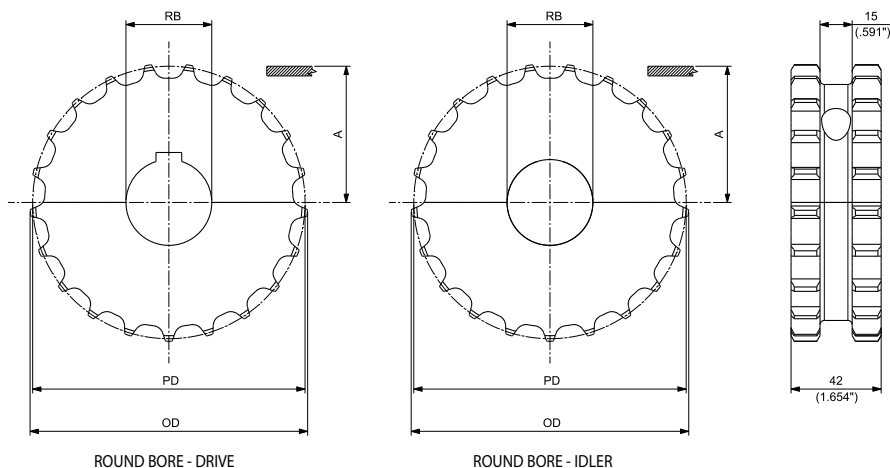

**MACHINED SPLIT IDLER WHEELS**  
SEE PAGE 126

## MACHINED SPLIT DRIVE AND IDLER SPROCKETS

N. TEETH	PITCH DIAMETER PD		OUTSIDE DIAMETER OD		WEAR STRIP POSITIONING A		BORE SIZE*		PART NUMBER ROUND BORE RB		WEIGHT	
	mm	inch	mm	inch	mm	inch	mm	inch**	DRIVE	IDLER	Kg	lbs
23	141,22	5.560	141,90	5.587	73,81	2.906	25		<b>CMAS028202325</b>	<b>CMAS038202325</b>	0,63	1.39
							30		<b>CMAS028202330</b>	<b>CMAS038202330</b>	0,62	1.37
							35		<b>CMAS028202335</b>	<b>CMAS038202335</b>	0,61	1.34
							40		<b>CMAS028202340</b>	<b>CMAS038202340</b>	0,59	1.31
							1		<b>CMAS0282023254</b>	<b>CMAS0382023254</b>	0,63	1.39
							1 ¼		<b>CMAS0282023317</b>	<b>CMAS0382023317</b>	0,63	1.39
							1 ⅜		<b>CMAS0282023349</b>	<b>CMAS0382023349</b>	0,62	1.37
25	153,20	6.031	154,20	6.071	79,80	3.142	25		<b>CMAS028202525</b>	<b>CMAS038202525</b>	0,78	1.72
							30		<b>CMAS028202530</b>	<b>CMAS038202530</b>	0,77	1.69
							35		<b>CMAS028202535</b>	<b>CMAS038202535</b>	0,76	1.67
							40		<b>CMAS028202540</b>	<b>CMAS038202540</b>	0,74	1.63
							1		<b>CMAS0282025254</b>	<b>CMAS0382025254</b>	0,78	1.71
							1 ¼		<b>CMAS0282025317</b>	<b>CMAS0382025317</b>	0,78	1.71
							1 ⅜		<b>CMAS0282025349</b>	<b>CMAS0382025349</b>	0,77	1.69
27	165,21	6.504	166,40	6.551	85,81	3.378	25		<b>CMAS028202725</b>	<b>CMAS038202725</b>	0,92	2.02
							30		<b>CMAS028202730</b>	<b>CMAS038202730</b>	0,91	2.03
							35		<b>CMAS028202735</b>	<b>CMAS038202735</b>	0,90	1.97
							40		<b>CMAS028202740</b>	<b>CMAS038202740</b>	0,88	1.94
							1		<b>CMAS0282027254</b>	<b>CMAS0382027254</b>	0,92	2.03
							1 ¼		<b>CMAS0282027317</b>	<b>CMAS0382027317</b>	0,92	2.03
							1 ⅜		<b>CMAS0282027349</b>	<b>CMAS0382027349</b>	0,91	2.03
1 ⅞		<b>CMAS0282027365</b>	<b>CMAS0382027365</b>	0,90	1.97							
1 ½		<b>CMAS0282027381</b>	<b>CMAS0382027381</b>	0,88	1.94							

\*Diameter is indicated.

\*\* Imperial round bore drive sprockets are supplied with setscrew. Metric round bore drive sprockets are supplied without setscrew.

## SUITABLE FOR CHAINS:

- 821
- HFX 821
- LBP 821

## MATERIALS

SPROCKETS: **PGF** REINFORCED POLYAMIDE

SCREWS: **SS** STAINLESS STEEL

NUTS: **B+NC** NICKEL PLATED BRASS

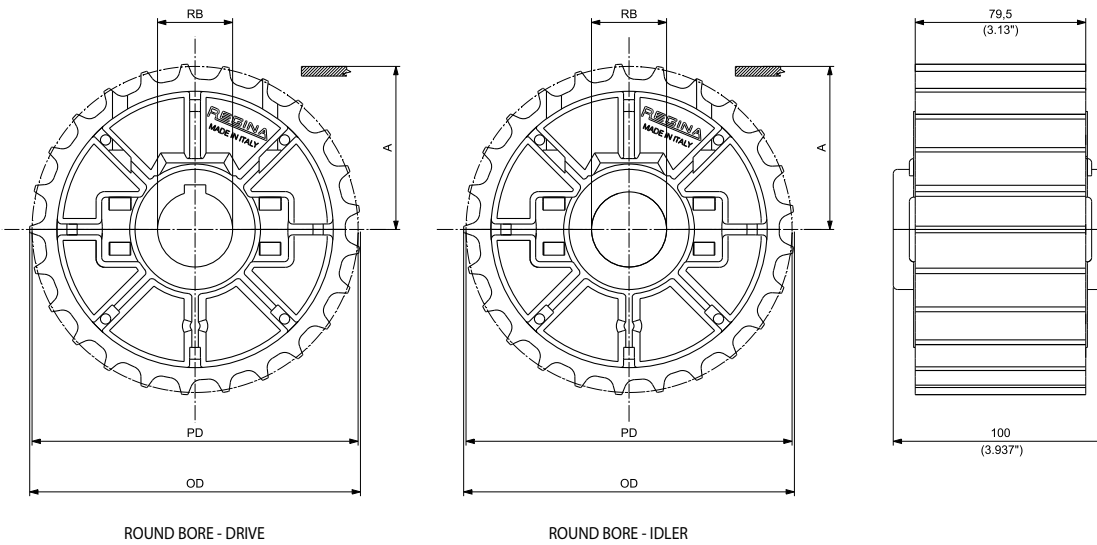

ROUND BORE - DRIVE

ROUND BORE - IDLER

## MOULDED SPLIT DRIVE AND IDLER SPROCKETS

N. TEETH	PITCH DIAMETER PD		OUTSIDE DIAMETER OD		WEAR STRIP POSITIONING A		BORE SIZE*		PART NUMBER ROUND BORE RB		WEIGHT	
	mm	inch	mm	inch	mm	inch	mm	inch**	DRIVE	IDLER	Kg	lbs
25	153,20	6.031	154,20	6.071	79,8	3.142	30		<b>CMT028212502</b>	<b>CMT038212502</b>	0,98	2.17
							35		<b>CMT028212503</b>	<b>CMT038212503</b>	0,97	2.13
							40		<b>CMT028212504</b>	<b>CMT038212504</b>	0,94	2.08
							45		<b>CMT028212505</b>	<b>CMT038212505</b>	0,91	2.02
							1 ¼		<b>CMT028212508</b>	<b>CMT038212508</b>	0,98	2.16
							1 ⅜		<b>CMT028212511</b>	<b>CMT038212511</b>	0,97	2.13
							1 7/16		<b>CMT028212509</b>	<b>CMT038212509</b>	0,96	2.11
							1 ½		<b>CMT028212510</b>	<b>CMT038212510</b>	0,95	2.10

\*Diameter is indicated.

\*\* Imperial round bore drive sprockets are supplied with setscrew. Metric round bore drive sprockets are supplied without setscrew.



## SUITABLE FOR CHAINS:

- 821
- HFX 821
- LBP 821

### MATERIALS

SPROCKETS:	<b>PA</b>	POLYAMIDE
SCREWS:	<b>SS</b>	STAINLESS STEEL
NUTS:	<b>B</b>	BRASS

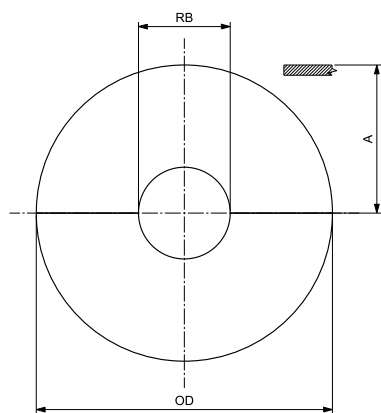

ROUND BORE - IDLER

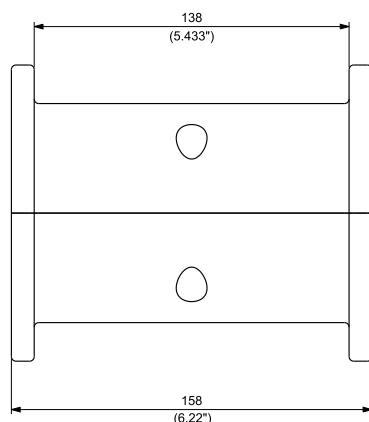

**MACHINED SPLIT SPROCKETS**  
SEE PAGE 128

## MACHINED SPLIT IDLER WHEELS

N. TEETH	OUTSIDE DIAMETER OD		WEAR STRIP POSITIONING A		BORE SIZE*		PART NUMBER ROUND BORE RB IDLER	WEIGHT	
	mm	inch	mm	inch	mm	inch		Kg	lbs
19	118,00	4.646	59,00	2.323	25		<b>CMAS048211925</b>	1,07	2,36
					30		<b>CMAS048211930</b>	1,03	2,27
					35		<b>CMAS048211935</b>	0,98	2,17
					40		<b>CMAS048211940</b>	0,93	2,05
					1		<b>CMAS0482119254</b>	1,07	2,35
					1 ¼		<b>CMAS0482119317</b>	1,03	2,27
					1 ⅜		<b>CMAS0482119349</b>	0,98	2,17
					1 ⅞		<b>CMAS0482119365</b>	0,97	2,13
					1 ½		<b>CMAS0482119381</b>	0,88	1,93
21	129,80	5.110	64,90	2.555	25		<b>CMAS048212125</b>	1,39	3.05
					30		<b>CMAS048212130</b>	1,35	2.97
					35		<b>CMAS048212135</b>	1,30	2.87
					40		<b>CMAS048212140</b>	1,25	2.75
					1		<b>CMAS0482121254</b>	1,38	3.05
					1 ¼		<b>CMAS0482121317</b>	1,38	3.05
					1 ⅜		<b>CMAS0482121349</b>	1,35	2.97
					1 ⅞		<b>CMAS0482121365</b>	1,30	2.87
					1 ½		<b>CMAS0482121381</b>	1,27	2.79
23	142,30	5.602	71,15	2.801	25		<b>CMAS048212325</b>	1,75	3.87
					30		<b>CMAS048212330</b>	1,72	3.78
					35		<b>CMAS048212335</b>	1,67	3.68
					40		<b>CMAS048212340</b>	1,62	3.56
					1		<b>CMAS0482123254</b>	1,75	3.86
					1 ¼		<b>CMAS0482123317</b>	1,75	3.86
					1 ⅜		<b>CMAS0482123349</b>	1,72	3.78
					1 ⅞		<b>CMAS0482123365</b>	1,67	3.68
					1 ½		<b>CMAS0482123381</b>	1,64	3.61
25	154,70	6.091	77,35	3.045	25		<b>CMAS048212525</b>	2,16	4.75
					30		<b>CMAS048212530</b>	2,12	4.67
					35		<b>CMAS048212535</b>	2,07	4.56
					40		<b>CMAS048212540</b>	2,02	4.45
					1		<b>CMAS0482125254</b>	2,15	4.75
					1 ¼		<b>CMAS0482125317</b>	2,15	4.75
					1 ⅜		<b>CMAS0482125349</b>	2,12	4.67
					1 ⅞		<b>CMAS0482125365</b>	2,07	4.56
					1 ½		<b>CMAS0482125381</b>	2,04	4.49

\*Diameter is indicated.

## SUITABLE FOR CHAINS:

- 828
- 880 / 880T / 880TA / 880M RG
- HFX 880T
- 879 / 879T
- 878T
- EW 878T / GW 878T
- GD 878T / GU 878T

### MATERIALS

SPROCKETS: **PGF** REINFORCED POLYAMIDE

SCREWS: **SS** STAINLESS STEEL

NUTS: **B+NC** NICKEL PLATED BRASS

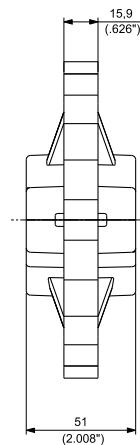
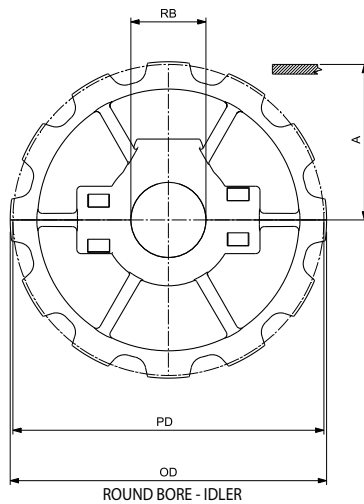
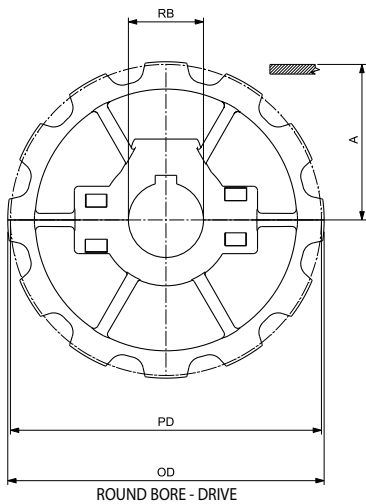

**MOULDED SPLIT  
IDLER WHEELS  
FOR 880 / 880M RG / 879 CHAINS**  
SEE PAGE 125



**MOULDED SOLID  
IDLER WHEELS  
FOR 880 / 880M RG / 879 CHAINS**  
SEE PAGE 124

## MOULDED SPLIT DRIVE AND IDLER SPROCKETS

N. TEETH	PITCH DIAMETER PD		OUTSIDE DIAMETER OD		WEAR STRIP POSITIONING A		BORE SIZE*		PART NUMBER		WEIGHT		
	mm	inch	mm	inch	mm	inch	mm	inch**	DRIVE	ROUND BORE RB	IDLER	Kg	lbs
NEW 10	123,29	4.854	124,50	4.902	65,25	2.569	1	1	CMT028801001	CMT038801001		0,31	0.68
									CMT028801002	CMT038801002		0,30	0.66
									CMT028801003	CMT038801003		0,29	0.64
									CMT028801004	CMT038801004		0,28	0.62
									CMT028801006	CMT038801006		0,31	0.67
									CMT028801008	CMT038801008		0,30	0.65
									CMT028801011	CMT038801011		0,30	0.65
									CMT028801009	CMT038801009		0,29	0.64
									CMT028801010	CMT038801010		0,29	0.64
									12	147,21	5.796	147,30	5.799
CMT028801202	CMT038801202		0,41	0.91									
CMT028801203	CMT038801203		0,40	0.88									
CMT028801204	CMT038801204		0,39	0.86									
CMT028801205	CMT038801205		0,37	0.82									
CMT028801206	CMT038801206		0,41	0.91									
CMT028801208	CMT038801208		0,41	0.90									
CMT028801211	CMT038801211		0,40	0.88									
CMT028801209	CMT038801209		0,40	0.88									
CMT028801210	CMT038801210		0,39	0.87									

\*Diameter is indicated.

\*\* Imperial round bore drive sprockets are supplied with setscrew. Metric round bore drive sprockets are supplied without setscrew.

## SUITABLE FOR CHAINS:

- 828
- 880 / 880T / 880TA / 880M RG
- HFX 880T
- 879 / 879T
- 878T
- EW 878T / GW 878T
- GD 878T / GU 878T

### MATERIALS

SPROCKETS: **PA** POLYAMIDE  
 SCREWS: **SS** STAINLESS STEEL  
 NUTS: **B** BRASS

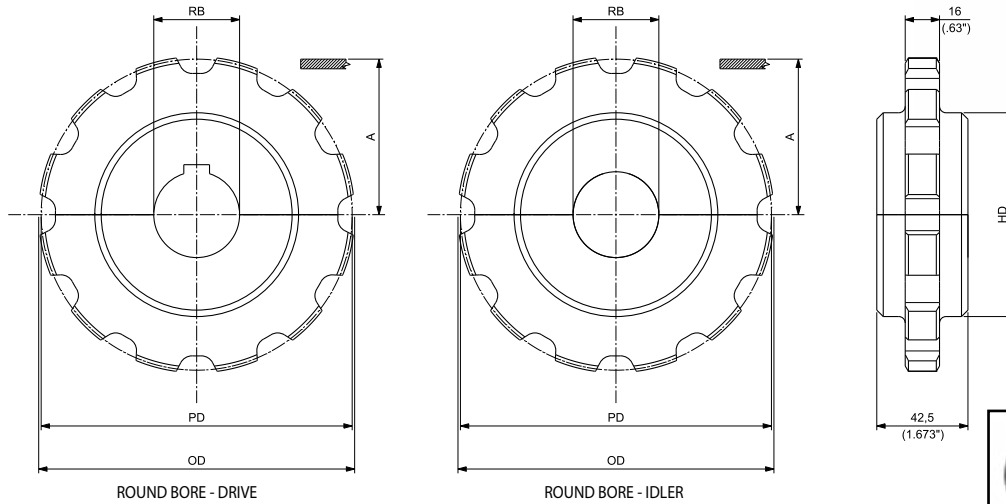

**MACHINED SPLIT  
 IDLER WHEELS  
 FOR 880 / 880M RG / 879 CHAINS**  
 SEE PAGE 126

## MACHINED SPLIT DRIVE AND IDLER SPROCKETS

N. TEETH	PITCH DIAMETER PD		OUTSIDE DIAMETER OD		WEAR STRIP POSITIONING A		HD		BORE SIZE*		PART NUMBER ROUND BORE RB		WEIGHT	
	mm	inch	mm	inch	mm	inch	mm	inch	mm	inch**	DRIVE	IDLER	Kg	lbs
9	111,40	4.386	109,80	4.323	59,30	2.335	75	2.95	25		CMAS028800925	CMAS038800925	0,30	0.66
									30		CMAS028800930	CMAS038800930	0,29	0.64
									35		CMAS028800935	CMAS038800935	0,28	0.61
									40		CMAS028800940	CMAS038800940	0,26	0.58
									1		CMAS0288009254	CMAS0388009254	0,30	0.66
									1 ¼		CMAS0288009317	CMAS0388009317	0,29	0.64
10	123,29	4.854	124,50	4.902	65,55	2.581	85	3.35	25		CMAS028801025	CMAS038801025	0,38	0.83
									30		CMAS028801030	CMAS038801030	0,37	0.81
									35		CMAS028801035	CMAS038801035	0,35	0.78
									40		CMAS028801040	CMAS038801040	0,34	0.75
									1		CMAS0288010254	CMAS0388010254	0,38	0.83
									1 ¼		CMAS0288010317	CMAS0388010317	0,37	0.81
11	135,24	5.324	134,90	5.311	71,22	2.804	90	3.54	25		CMAS028801125	CMAS038801125	0,43	0.95
									30		CMAS028801130	CMAS038801130	0,42	0.93
									35		CMAS028801135	CMAS038801135	0,41	0.90
									40		CMAS028801140	CMAS038801140	0,40	0.87
									1		CMAS0288011254	CMAS0388011254	0,43	0.95
									1 ¼		CMAS0288011317	CMAS0388011317	0,41	0.90
12	147,21	5.796	147,30	5.799	77,21	3.040	95	3.74	25		CMAS028801225	CMAS038801225	0,53	1.17
									30		CMAS028801230	CMAS038801230	0,52	1.14
									35		CMAS028801235	CMAS038801235	0,51	1.12
									40		CMAS028801240	CMAS038801240	0,49	1.09
									1		CMAS0288012254	CMAS0388012254	0,53	1.17
									1 ¼		CMAS0288012317	CMAS0388012317	0,51	1.12
		1 ½		CMAS0288012381	CMAS0388012381	0,50	1.10							

\*Diameter is indicated.

\*\* Imperial round bore drive sprockets are supplied with setscrew. Metric round bore drive sprockets are supplied without setscrew.

## SUITABLE FOR CHAINS:

- 880T / HFX 880T / 880TA
- 879T
- 878T
- EW 878T / GW 878T / GU 878T / GD 878T

## MATERIALS

SPROCKETS: **PA** POLYAMIDE

SCREWS: **SS** STAINLESS STEEL

NUTS: **B** BRASS

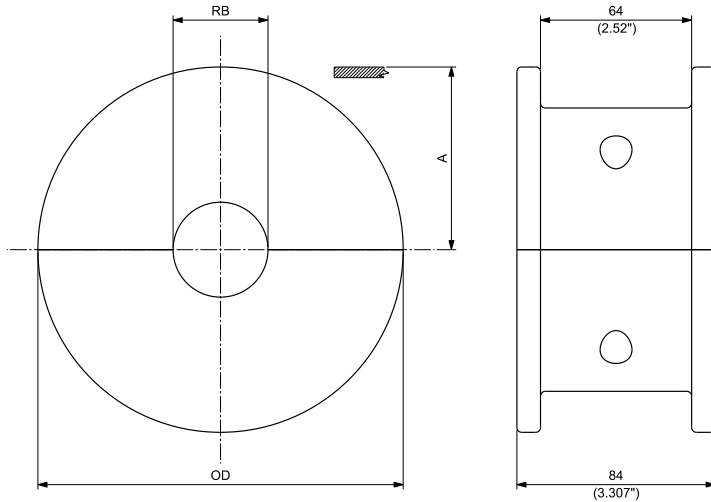

ROUND BORE - IDLER

## MACHINED SPLIT IDLER WHEELS

N. TEETH	OUTSIDE DIAMETER OD		WEAR STRIP POSITIONING A		BORE SIZE*		PART NUMBER ROUND BORE IDLER	WEIGHT	
	mm	inch	mm	inch	mm	inch		Kg	lbs
9	118,00	4.646	59,00	2.323	25		<b>CMAS04880T0925</b>	0,64	1.41
					30		<b>CMAS04880T0930</b>	0,62	1.36
					35		<b>CMAS04880T0935</b>	0,59	1.31
					40		<b>CMAS04880T0940</b>	0,57	1.25
					1		<b>CMAS04880T09254</b>	0,64	1.41
					1 ¼		<b>CMAS04880T09317</b>	0,62	1.36
					1 ½		<b>CMAS04880T09381</b>	0,59	1.31
10	129,80	5.110	64,90	2.555	25		<b>CMAS04880T1025</b>	0,82	1.80
					30		<b>CMAS04880T1030</b>	0,80	1.75
					35		<b>CMAS04880T1035</b>	0,77	1.70
					40		<b>CMAS04880T1040</b>	0,74	1.64
					1		<b>CMAS04880T10254</b>	0,82	1.80
					1 ¼		<b>CMAS04880T10317</b>	0,77	1.70
					1 ½		<b>CMAS04880T10381</b>	0,75	1.66
11	142,30	5.602	71,15	2.801	25		<b>CMAS04880T1125</b>	1,02	2.25
					30		<b>CMAS04880T1130</b>	1,00	2.20
					35		<b>CMAS04880T1135</b>	0,98	2.15
					40		<b>CMAS04880T1140</b>	0,95	2.09
					1		<b>CMAS04880T11254</b>	1,02	2.25
					1 ¼		<b>CMAS04880T11317</b>	0,98	2.15
					1 ½		<b>CMAS04880T11381</b>	0,96	2.11
12	154,70	6.091	77,35	3.045	25		<b>CMAS04880T1225</b>	1,24	2.74
					30		<b>CMAS04880T1230</b>	1,22	2.69
					35		<b>CMAS04880T1235</b>	1,20	2.64
					40		<b>CMAS04880T1240</b>	1,17	2.57
					1		<b>CMAS04880T12254</b>	1,24	2.73
					1 ¼		<b>CMAS04880T12317</b>	1,20	2.64
					1 ½		<b>CMAS04880T12381</b>	1,18	2.60

\*Diameter is indicated.

## SUITABLE FOR CHAINS:

- 8257
- HFX 8257
- LBP 8257
- 882 / 882T / 882M
- HFX 882T / HFX 882M
- LBP 882T / LBP 882M

## MATERIALS

SPROCKETS: **PGF** REINFORCED POLYAMIDE

SCREWS: **SS** STAINLESS STEEL

NUTS: **B+NC** NICKEL PLATED BRASS

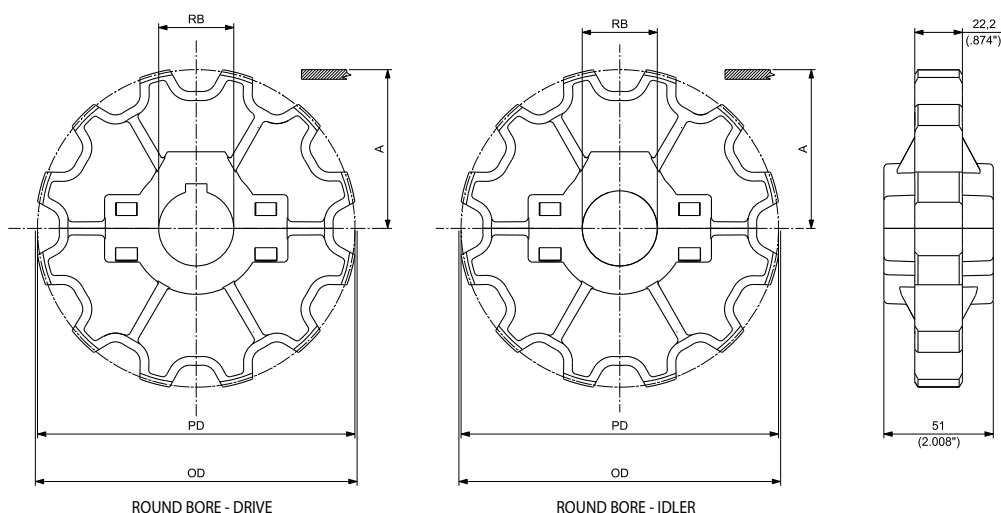

## MOULDED SPLIT DRIVE AND IDLER SPROCKETS

N. TEETH	PITCH DIAMETER PD		OUTSIDE DIAMETER OD		WEAR STRIP POSITIONING A		BORE SIZE*		PART NUMBER ROUND BORE RB		WEIGHT	
	mm	inch	mm	inch	mm	inch	mm	inch**	DRIVE	IDLER	Kg	lbs
10	123,29	4.854	124,50	4.902	66,35	2.612	1	1	CMT028821001	CMT038821001	0,30	0.65
									CMT028821002	CMT038821002	0,29	0.64
									CMT028821003	CMT038821003	0,28	0.62
									CMT028821004	CMT038821004	0,27	0.60
									CMT028821006	CMT038821006	0,30	0.65
									CMT028821008	CMT038821008	0,30	0.65
12	147,21	5.796	150,00	5.906	78,31	3.083	1	1	CMT028821009	CMT038821009	0,28	0.62
									CMT028821010	CMT038821010	0,27	0.60
									CMT028821201	CMT038821201	0,40	0.88
									CMT028821202	CMT038821202	0,39	0.86
									CMT028821203	CMT038821203	0,38	0.83
									CMT028821204	CMT038821204	0,37	0.81
									CMT028821205	CMT038821205	0,35	0.78
									CMT028821206	CMT038821206	0,39	0.86
									CMT028821208	CMT038821208	0,39	0.85
									CMT028821210	CMT038821210	0,35	0.78

\*Diameter is indicated.

\*\* Imperial round bore drive sprockets are supplied with setscrew. Metric round bore drive sprockets are supplied without setscrew.

## SUITABLE FOR CHAINS:

- 8257
- HFX 8257
- LBP 8257
- 882 / 882T / 882M
- HFX 882T / HFX 882M
- LBP 882T / LBP 882M

### MATERIALS

SPROCKETS: **PA** POLYAMIDE  
 SCREWS: **SS** STAINLESS STEEL  
 NUTS: **B** BRASS

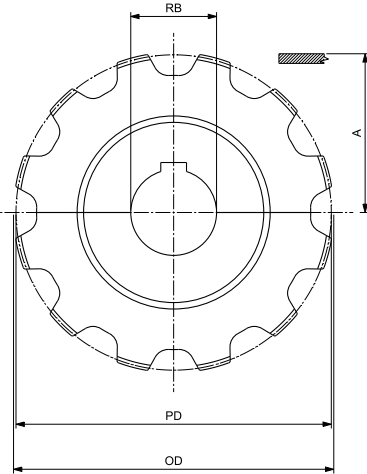

ROUND BORE - DRIVE

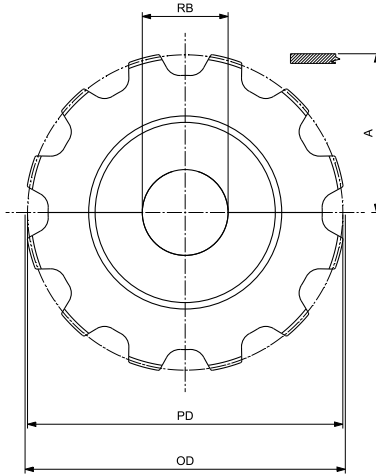

ROUND BORE - IDLER

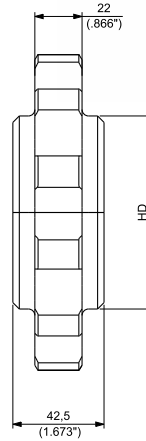

## MACHINED SPLIT DRIVE AND IDLER SPROCKETS

N. TEETH	PITCH DIAMETER PD		OUTSIDE DIAMETER OD		WEAR STRIP POSITIONING A		HD		BORE SIZE*		PART NUMBER ROUND BORE RB		WEIGHT	
	mm	inch	mm	inch	mm	inch	mm	inch	mm	inch**	DRIVE	IDLER	Kg	lbs
9	111,40	4.386	109,80	4.323	60,40	2.378	60	2.36	25		CMAS028820925	CMAS038820925	0,28	0.62
									30		CMAS028820930	CMAS038820930	0,27	0.60
									35		CMAS028820935	CMAS038820935	0,26	0.57
									40		CMAS028820940	CMAS038820940	0,25	0.54
									1		CMAS0288209254	CMAS0388209254	0,28	0.62
									1 ¼		CMAS0288209317	CMAS0388209317	0,27	0.59
									1 ½		CMAS0288209381	CMAS0388209381	0,25	0.55
10	123,29	4.878	122,40	4.819	66,65	2.624	75	2.95	25		CMAS028821025	CMAS038821025	0,37	0.82
									30		CMAS028821030	CMAS038821030	0,36	0.80
									35		CMAS028821035	CMAS038821035	0,35	0.77
									40		CMAS028821040	CMAS038821040	0,34	0.74
									1		CMAS0288210254	CMAS0388210254	0,37	0.82
									1 ¼		CMAS0288210317	CMAS0388210317	0,35	0.76
									1 ½		CMAS0288210381	CMAS0388210381	0,30	0.67
11	135,24	5.324	134,90	5.311	72,32	2.874	85	3.35	25		CMAS028821125	CMAS038821125	0,45	1.00
									30		CMAS028821130	CMAS038821130	0,44	0.98
									35		CMAS028821135	CMAS038821135	0,43	0.95
									40		CMAS028821140	CMAS038821140	0,42	0.92
									1		CMAS0288211254	CMAS0388211254	0,45	1.00
									1 ¼		CMAS0288211317	CMAS0388211317	0,43	0.95
									1 ½		CMAS0288211381	CMAS0388211381	0,42	0.93
12	147,21	5.796	147,30	5.799	78,31	3.083	90	3.54	25		CMAS028821225	CMAS038821225	0,56	1.24
									30		CMAS028821230	CMAS038821230	0,55	1.21
									35		CMAS028821235	CMAS038821235	0,54	1.18
									40		CMAS028821240	CMAS038801240	0,52	1.15
									1		CMAS0288212254	CMAS0388212254	0,56	1.23
									1 ¼		CMAS0288212317	CMAS0388212317	0,54	1.18
									1 ½		CMAS0288212381	CMAS0388212381	0,53	1.17

\*Diameter is indicated.

\*\* Imperial round bore drive sprockets are supplied with setscrew. Metric round bore drive sprockets are supplied without setscrew.



## SUITABLE FOR CHAINS:

- 882T
- HFX 882T
- LBP 882T

## MATERIALS

SPROCKETS:	<b>PA</b>	POLYAMIDE
SCREWS:	<b>SS</b>	STAINLESS STEEL
NUTS:	<b>B</b>	BRASS

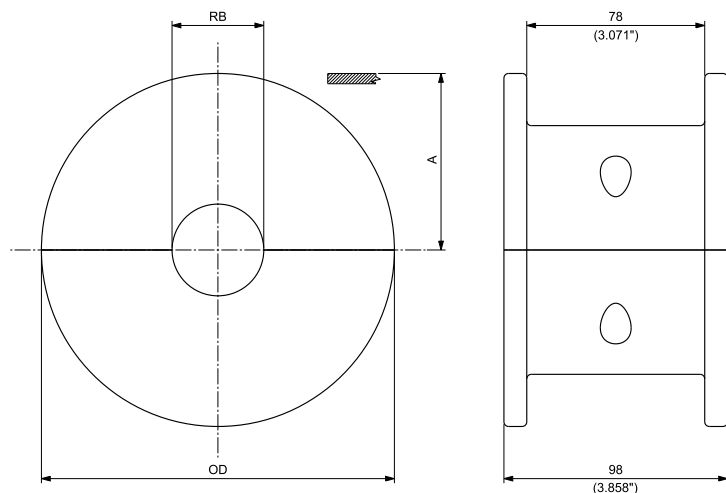

ROUND BORE - IDLER

## MACHINED SPLIT IDLER WHEELS

N. TEETH	OUTSIDE DIAMETER OD		WEAR STRIP POSITIONING A		BORE SIZE*		PART NUMBER ROUND BORE RB IDLER	WEIGHT	
	mm	inch	mm	inch	mm	inch		Kg	lbs
9	118,00	4.646	59,00	2.323	25		<b>CMAS04882T0925</b>	0,59	1.30
					30		<b>CMAS04882T0930</b>	0,57	1.25
					35		<b>CMAS04882T0935</b>	0,54	1.18
					40		<b>CMAS04882T0940</b>	0,50	1.11
					1		<b>CMAS04882T09254</b>	0,59	1.30
					1 ¼		<b>CMAS04882T09317</b>	0,56	1.23
					1 ½		<b>CMAS04882T09381</b>	0,52	1.14
10	129,80	5.110	64,90	2.555	25		<b>CMAS04882T1025</b>	0,79	1.74
					30		<b>CMAS04882T1030</b>	0,76	1.67
					35		<b>CMAS04882T1045</b>	0,73	1.60
					40		<b>CMAS04882T1040</b>	0,69	1.53
					1		<b>CMAS04882T10254</b>	0,78	1.72
					1 ¼		<b>CMAS04882T10317</b>	0,72	1.58
					1 ½		<b>CMAS04882T10381</b>	0,62	1.37
11	142,30	5.602	71,15	2.801	25		<b>CMAS04882T1125</b>	0,98	2.17
					30		<b>CMAS04882T1130</b>	0,96	2.12
					35		<b>CMAS04882T1135</b>	0,93	2.05
					40		<b>CMAS04882T1140</b>	0,90	1.98
					1		<b>CMAS04882T11254</b>	0,98	2.17
					1 ¼		<b>CMAS04882T11317</b>	0,93	2.05
					1 ½		<b>CMAS04882T11381</b>	0,91	2.01
12	154,70	6.091	77,35	3.045	25		<b>CMAS04882T1225</b>	1,24	2.74
					30		<b>CMAS04882T1230</b>	1,22	2.69
					35		<b>CMAS04882T1235</b>	1,19	2.62
					40		<b>CMAS04882T1240</b>	1,16	2.55
					1		<b>CMAS04882T12254</b>	1,24	2.74
					1 ¼		<b>CMAS04882T12317</b>	1,19	2.62
					1 ½		<b>CMAS04882T12381</b>	1,17	2.58

\*Diameter is indicated.

## SUITABLE FOR CHAINS:

- 843
- 845
- RR 845
- HF RR 845
- 1843T
- EW 1843T

## MATERIALS

SPROCKETS: **S** CARBON STEEL

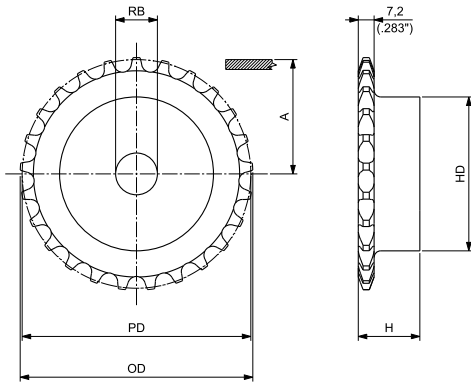

## MACHINED SOLID SPROCKETS

N. TEETH	PITCH DIAMETER PD		OUTSIDE DIAMETER OD		WEAR STRIP POSITIONING A		HD		H		BORE SIZE**		PART NUMBER ROUND BORE RB	WEIGHT	
	mm	inch	mm	inch	mm	inch	mm	inch	mm	inch	mm	inch		Kg	lbs
13*	50,06	1.971	57,40	2.260	30,93	1.218	37	1.46	28	1.10	10	0.39	<b>CMA028431300</b>	0,28	0.62
15*	61,09	2.405	65,50	2.579	36,45	1.435	45	1.76	28	1.10	10	0.39	<b>CMA028431500</b>	0,41	0.90
17*	69,11	2.721	73,60	2.898	40,46	1.593	52	2.05	28	1.10	10	0.39	<b>CMA028431700</b>	0,54	1.19
19	77,16	3.038	81,70	3.217	44,48	1.751	60	2.36	28	1.10	12	0.47	<b>CMA028431900</b>	0,70	1.54
21	85,22	3.355	89,70	3.531	48,51	1.910	68	2.68	28	1.10	12	0.47	<b>CMA028432100</b>	0,89	1.96
23	93,27	3.672	98,20	3.866	52,54	2.068	70	2.76	28	1.10	12	0.47	<b>CMA028432300</b>	0,98	2.16
25	101,33	3.989	105,80	4.165	56,57	2.227	70	2.76	28	1.10	12	0.47	<b>CMA028432500</b>	1,06	2.34
27	109,40	4.307	114,00	4.488	60,60	2.386	70	2.76	30	1.18	15	0.59	<b>CMA028432700</b>	1,17	2.58
29	117,46	4.624	122,00	4.803	64,63	2.544	80	3.15	30	1.18	15	0.59	<b>CMA028432900</b>	1,47	3.24
31	125,54	4.943	130,20	5.126	68,67	2.704	90	3.54	30	1.18	16	0.63	<b>CMA028433100</b>	1,79	3.95
33	130,66	5.144	138,40	5.449	71,23	2.804	90	3.54	30	1.18	16	0.63	<b>CMA028433300</b>	1,88	4.14

\*Cannot work with 1843T and EW 1843T series.

\*\*Diameter is indicated (plain bore).

## SUITABLE FOR CHAINS:

- 1864 / 1874T
- 863
- 1863T
- 1873T
- HFX 1873T
- GV 1874T / EV 1874T
- GW 1873T / EW 1873T /  
GD 1873T / GU 1873T
- GC 1873T

## MATERIALS

SPROCKETS: **S** CARBON STEEL

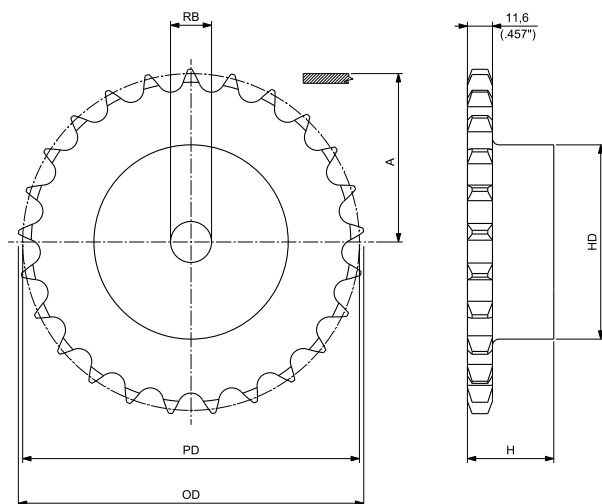

## MACHINED SOLID SPROCKETS

N. TEETH	PITCH DIAMETER PD		OUTSIDE DIAMETER OD		WEAR STRIP POSITIONING A		HD		H		BORE SIZE**		PART NUMBER ROUND BORE RB	WEIGHT	
	mm	inch	mm	inch	mm	inch	mm	inch	mm	inch	mm	inch		Kg	lbs
15*	91,63	3.607	99,80	3.929	56,22	2.213	70	2.76	35	1.38	14	0.55	<b>CMA028631500</b>	1,26	2.78
17*	103,67	4.081	111,50	4.390	62,24	2.450	80	3.15	35	1.38	16	0.63	<b>CMA028631700</b>	1,67	3.68
19	115,75	4.557	124,20	4.890	68,28	2.688	80	3.15	35	1.38	16	0.63	<b>CMA028631900</b>	1,82	4.01
21	127,82	5.032	136,00	5.354	74,31	2.926	90	3.54	40	1.57	20	0.79	<b>CMA028632100</b>	2,48	5.47
23	139,90	5.508	149,00	5.866	80,35	3.163	90	3.54	40	1.57	20	0.79	<b>CMA028632300</b>	2,71	5.97
25	152,00	5.984	160,00	6.299	86,40	3.402	90	3.54	40	1.57	20	0.79	<b>CMA028632500</b>	2,91	6.42
27	164,09	6.460	172,30	6.783	92,45	3.640	95	3.74	40	1.57	20	0.79	<b>CMA028632700</b>	3,39	7.47
29	176,19	6.937	184,10	7.248	98,50	3.878	95	3.74	40	1.57	20	0.79	<b>CMA028632900</b>	3,68	8.11
31	188,31	7.414	196,30	7.728	104,56	4.116	100	3.94	40	1.57	25	0.98	<b>CMA028633100</b>	4,18	9.22

\*Cannot work with 1863T, 1873T, 1864, 1874T, HFX 1873T, EV 1874T, GD 1874T, GW 1873T, EW 1873T, GD 1873T, GU 1873T and GC 1873T series.

\*\*Diameter is indicated (plain bore).

## SUITABLE FOR CHAINS:

- 1883
- HFX 1883

## MATERIALS

SPROCKETS: **S** CARBON STEEL

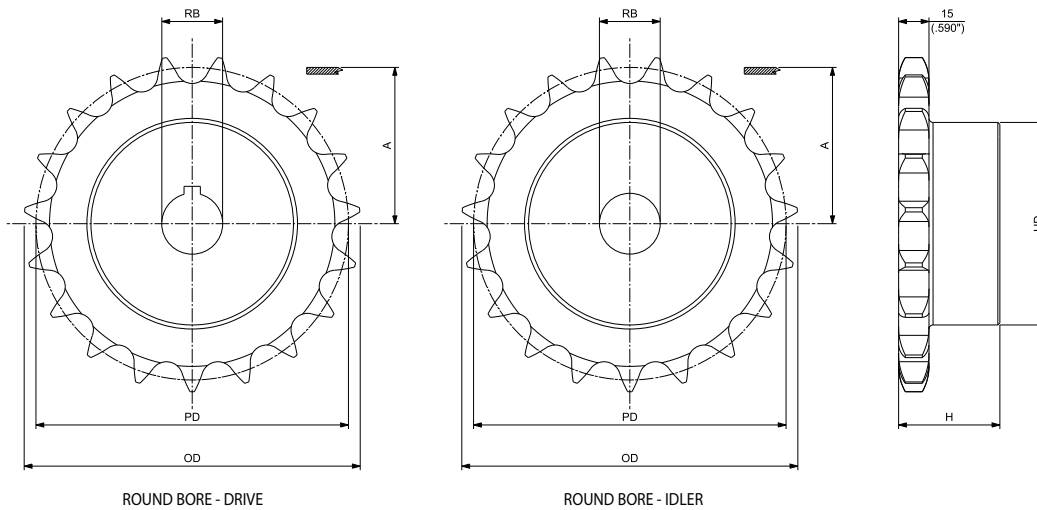

## MACHINED SOLID SPROCKETS

N. TEETH	PITCH DIAMETER PD		OUTSIDE DIAMETER OD		WEAR STRIP POSITIONING A		HD		H		BORE SIZE*		PART NUMBER ROUND BORE RB		WEIGHT	
	mm	inch	mm	inch	mm	inch	mm	inch	mm	inch	mm	inch	DRIVE	IDLER	Kg	lbs
19	154,14	6.609	166,00	6.535	93,97	3.678	100	3.937	45	1.772	40	<b>CMA0218831904</b>	<b>CMA0318831904</b>	3,70	8.16	
											1 ½	<b>CMA0218831910</b>	<b>CMA0318831910</b>	3,70	8.16	

\*Diameter is indicated.

## SUITABLE FOR CHAINS:

- 1700
- 1710
- 1702
- 1701T

### MATERIALS

SPROCKETS: **PA** POLYAMIDE

SCREWS: **SS** STAINLESS STEEL

NUTS: **B** BRASS



## 8T & 10T SPROCKETS

(for 12T & 13T see next page)

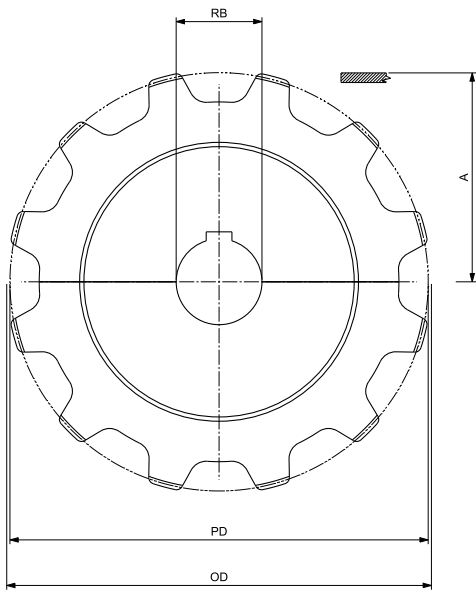

ROUND BORE - DRIVE

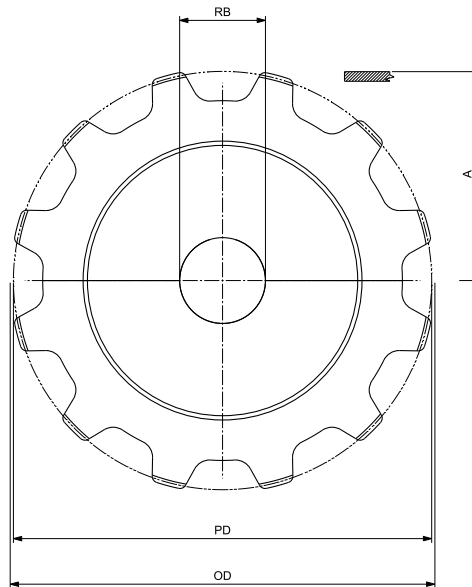

ROUND BORE - IDLER

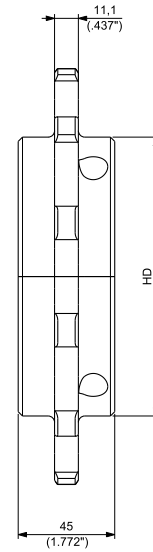

## MACHINED SPLIT DRIVE AND IDLER SPROCKETS

N. TEETH	PITCH DIAMETER PD		OUTSIDE DIAMETER OD		WEAR STRIP POSITIONING A		HD		BORE SIZE*		PART NUMBER ROUND BORE RB		WEIGHT	
	mm	inch	mm	inch	mm	inch	mm	inch	mm	inch**	DRIVE	IDLER	Kg	lbs
8	130,66	5.144	132,30	5.209	53,33	2.100	80	3.15	25		<b>CMAS0217000825</b>	<b>CMAS0317000825</b>	0,34	0.75
									30		<b>CMAS0217000830</b>	<b>CMAS0317000830</b>	0,33	0.73
									35		<b>CMAS0217000835</b>	<b>CMAS0317000835</b>	0,32	0.70
									40		<b>CMAS0217000840</b>	<b>CMAS0317000840</b>	0,30	0.66
										1	<b>CMAS02170008254</b>	<b>CMAS03170008254</b>	0,34	0.75
										1 ¼	<b>CMAS02170008317</b>	<b>CMAS03170008317</b>	0,33	0.73
										1 ⅜	<b>CMAS02170008349</b>	<b>CMAS03170008349</b>	0,32	0.70
										1 ⅞	<b>CMAS02170008365</b>	<b>CMAS03170008365</b>	0,31	0.68
10	161,80	6.370	165,20	6.504	68,90	2.713	110	4.33	25		<b>CMAS0217001025</b>	<b>CMAS0317001025</b>	0,60	1.32
									30		<b>CMAS0217001030</b>	<b>CMAS0317001030</b>	0,59	1.30
									35		<b>CMAS0217001035</b>	<b>CMAS0317001035</b>	0,57	1.27
									40		<b>CMAS0217001040</b>	<b>CMAS0317001040</b>	0,56	1.23
										1	<b>CMAS02170010254</b>	<b>CMAS03170010254</b>	0,61	1.34
										1 ¼	<b>CMAS02170010317</b>	<b>CMAS03170010317</b>	0,60	1.32
										1 ⅜	<b>CMAS02170010349</b>	<b>CMAS03170010349</b>	0,59	1.30
										1 ⅞	<b>CMAS02170010365</b>	<b>CMAS03170010365</b>	0,57	1.27
	1 ½	<b>CMAS02170010381</b>	<b>CMAS03170010381</b>	0,56	1.23									

\*Diameter is indicated.

\*\* Imperial round bore drive sprockets are supplied with setscrew. Metric round bore drive sprockets are supplied without setscrew.

## SUITABLE FOR CHAINS:

- 1700
- 1710
- 1702
- 1701T

### MATERIALS

SPROCKETS: **PA** POLYAMIDE

SCREWS: **SS** STAINLESS STEEL

NUTS: **B** BRASS



## 12T & 13T SPROCKETS

(for 8T & 10T see previous page)

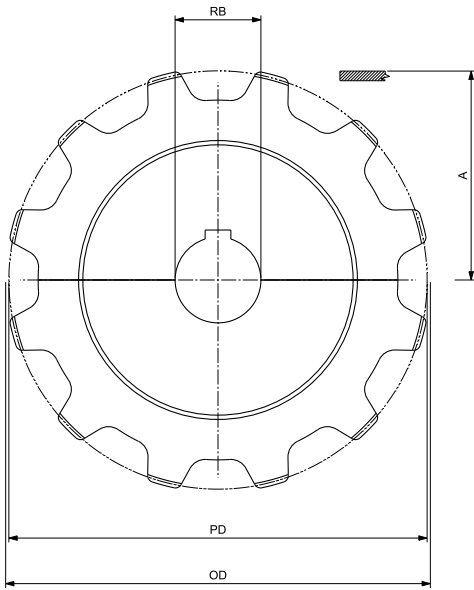

ROUND BORE - DRIVE

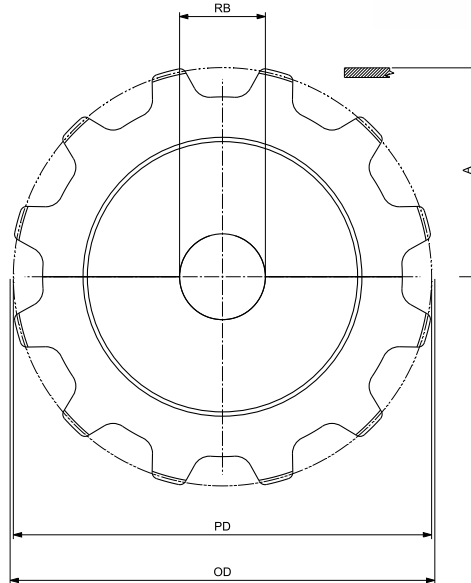

ROUND BORE - IDLER

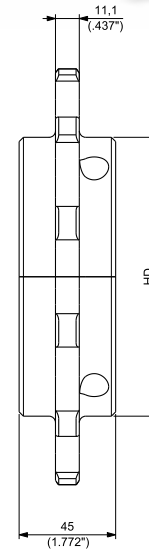

## MACHINED SPLIT DRIVE AND IDLER SPROCKETS

N. TEETH	PITCH DIAMETER PD		OUTSIDE DIAMETER OD		WEAR STRIP POSITIONING A		HD		BORE SIZE*		PART NUMBER ROUND BORE RB		WEIGHT	
	mm	inch	mm	inch	mm	inch	mm	inch	mm	inch**	DRIVE	IDLER	Kg	lbs
12	193,19	7.606	198,00	7.795	84,60	3.331	130	5.12	1	25	CMAS0217001225	CMAS0317001225	0,84	1.85
										30	CMAS0217001230	CMAS0317001230	0,83	1.83
										35	CMAS0217001235	CMAS0317001235	0,82	1.80
										40	CMAS0217001240	CMAS0317001240	0,80	1.77
										1 ¼	CMAS02170012254	CMAS03170012254	0,84	1.85
										1 ⅜	CMAS02170012317	CMAS03170012317	0,84	1.85
										1 ⅝	CMAS02170012349	CMAS03170012349	0,83	1.83
13	208,93	8.226	214,20	8.433	92,47	3.641	150	5.91	1	25	CMAS0217001325	CMAS0317001325	0,84	1.85
										30	CMAS0217001330	CMAS0317001330	0,83	1.83
										35	CMAS0217001335	CMAS0317001335	0,82	1.80
										40	CMAS0217001340	CMAS0317001340	0,80	1.77
										1 ¼	CMAS02170013254	CMAS03170013254	0,84	1.85
										1 ⅜	CMAS02170013317	CMAS03170013317	0,84	1.85
										1 ⅝	CMAS02170013349	CMAS03170013349	0,83	1.83
										1 ⅞	CMAS02170013365	CMAS03170013365	0,82	1.80
										1 ½	CMAS02170013381	CMAS03170013381	0,81	1.78

\*Diameter is indicated.

\*\* Imperial round bore drive sprockets are supplied with setscrew. Metric round bore drive sprockets are supplied without setscrew.





PERFORMANCE IN MOTION







PERFORMANCE IN MOTION

**Matveyor**<sup>®</sup>

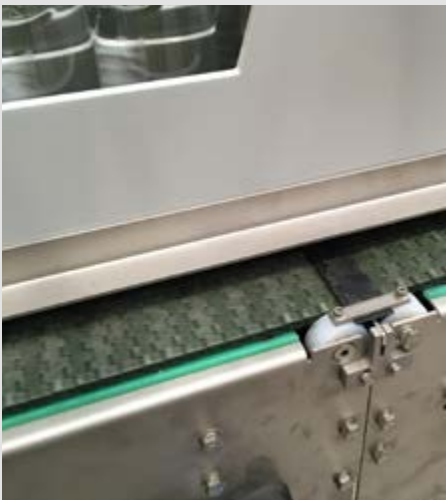



PERFORMANCE IN MOTION

# Matveyor<sup>®</sup>

## 8mm Nanopitch Belt

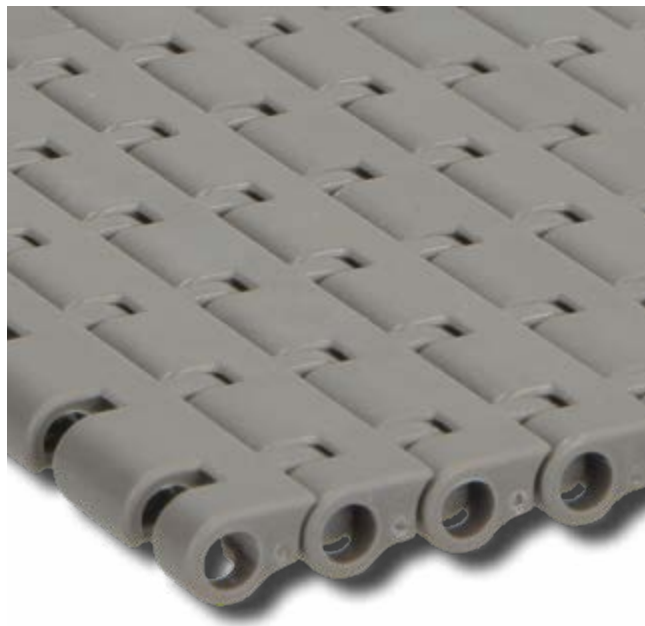

## INDUSTRIES AND APPLICATIONS

Suitable for handling unstable and delicate products with small foot-print (loose or packaged) in a nose-over linear transfer from the head of one conveyor to the next one.

### INDUSTRIES

Bottling and canning  
 Food filling  
 Container manufacturing  
 Pharmaceutical  
 Paper/cardboard  
 Consumer goods

### APPLICATIONS

Infeed/outfeed packaging machines  
 Product handling within packaging machine  
 Dynamic alternative to the dead transfer plate between two conveyors equipped with longer pitch belts that do not allow for direct tight product transfer

## FEATURES

- Super-short pitch of 8 mm (0.315"), with no chordal effect in the engagement with sprockets or nosebar, allowing the maximization of product stability during head transfer.
- Pinless and clipless snap-on assembly, easing belt installation and eliminating complexity related to belt closing junction.
- Highest mechanical strength among all 8 mm pitch belts available on the market with independent pin assembly.

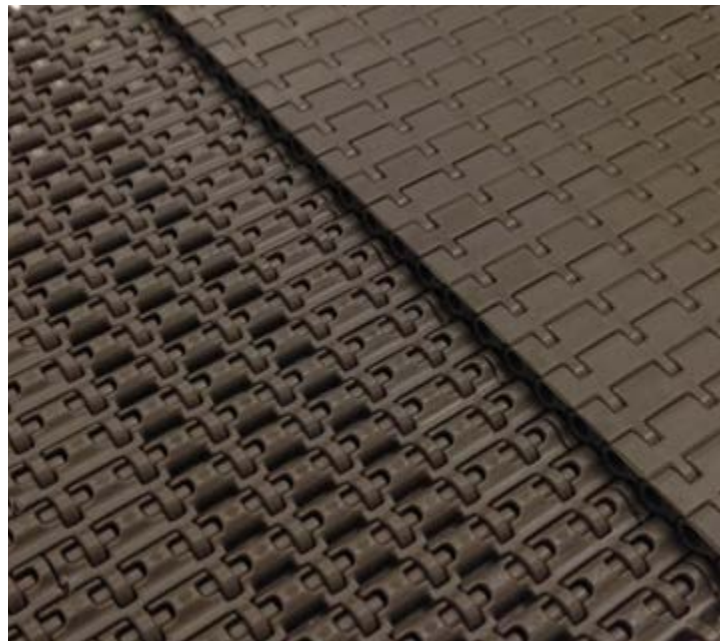
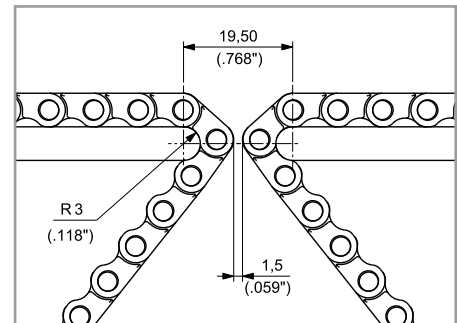

## BELT ASSEMBLY



1) Bring the two ends of the belt close to each other on the conveyor.



2) Insert each pin on one side of the belt into its corresponding hinge on the other side of the belt. Please make sure the hinges are positioned above their corresponding pins.

### REQUIRED TOOLS

- Pin with 6 mm diameter and length  $L = \text{belt width} + 40 \text{ mm}$



3) Use the mounting pin in the conjunction area under the belt, position the pin symmetrically across the belt width.



4) Starting from one edge, press the hinges into their corresponding pins all across the belt width. When the operation is finished, please remember to check that hinges and pins are joint correctly.

## BELT DISASSEMBLY



1) Insert the mounting pin under the hinges of the belt to be disassembled.



2) Insert the screwdriver into the space between the hinges.  
NOTE: The screwdriver should have the dimensions indicated above.

### REQUIRED TOOLS

- Pin with 6 mm diameter and length  $L = \text{belt width} + 40 \text{ mm}$   
- Screwdriver:

$a =$  

$b =$  

$a_{\text{max}} = 1,2 \text{ mm}$   
 $b_{\text{max}} = 6,5 \text{ mm}$



3) Slightly leverage the screwdriver to separate the pins from their corresponding hinges.



4) Repeat the previous operation all across the belt width so that it will be disassembled along one single transversal direction.



### 6,15 mm (0.242") THICKNESS SOLID TOP

**NEW**



Ideal to equip conveyors with tight nose-over transfer of unstable and delicate products with small foot-print. Particularly suitable for the following applications:

- As a dynamic alternative to the dead transfer plate between two conveyors equipped with longer pitch belts that do not allow for direct transfer of tight products.
- Product handling within packaging machines.
- All other unstable and delicate small foot-print loose products handling applications.

- **Belt widths:** 76,2 mm (3") or wider in 76,2 mm (3") increments
- **Working Load (at 25°C/77°F):** 8000 N/m (548 lbs/ft) for **UP** and **DK<sup>2</sup>** materials  
6500 N/m (445 lbs/ft) for **AR** material
- **Belt weight:** 5,36 kg/m<sup>2</sup> (1.10 lbs/ft<sup>2</sup>) for **UP** and **DK<sup>2</sup>** materials  
5,14 kg/m<sup>2</sup> (1.05 lbs/ft<sup>2</sup>) for **AR** material

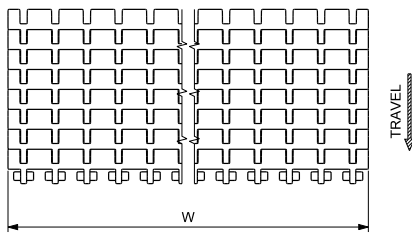
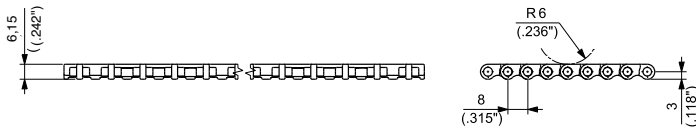

Materials  
see page 12



Sprockets  
see pages 164-165



Applications  
see page 22

WIDTH W		MATERIALS		
		Module		
mm	inch	<b>UP</b>	<b>DK<sup>2</sup></b>	<b>AR</b>
		ULTRA PERFORMANCE HOMOPOLYMER DELRIN®	SPECIAL DELRIN® REINFORCED WITH KEVLAR®	ABRASION RESISTANT POLYAMIDE*
		PART NUMBER	PART NUMBER	PART NUMBER
76,2	3	<b>8300UP003</b>	<b>8300D2K003</b>	<b>8300AR003</b>
152,4	6	<b>8300UP006</b>	<b>8300D2K006</b>	<b>8300AR006</b>
228,6	9	<b>8300UP009</b>	<b>8300D2K009</b>	<b>8300AR009</b>
304,8	12	<b>8300UP012</b>	<b>8300D2K012</b>	<b>8300AR012</b>
381,0	15	<b>8300UP015</b>	<b>8300D2K015</b>	<b>8300AR015</b>
457,2	18	<b>8300UP018</b>	<b>8300D2K018</b>	<b>8300AR018</b>
533,4	21	<b>8300UP021</b>	<b>8300D2K021</b>	<b>8300AR021</b>
609,6	24	<b>8300UP024</b>	<b>8300D2K024</b>	<b>8300AR024</b>
685,8	27	<b>8300UP027</b>	<b>8300D2K027</b>	<b>8300AR027</b>
762,0	30	<b>8300UP030</b>	<b>8300D2K030</b>	<b>8300AR030</b>
838,2	33	<b>8300UP033</b>	<b>8300D2K033</b>	<b>8300AR033</b>
914,4	36	<b>8300UP036</b>	<b>8300D2K036</b>	<b>8300AR036</b>
990,6	39	<b>8300UP039</b>	<b>8300D2K039</b>	<b>8300AR039</b>

Belts wider than 990,6 mm (39") are available in 76,2 mm (3") increments.  
To identify the Part Numbers, please substitute the last three digits of the PN with the desired width.  
Example: for a 42" wide belt (=39+3"), the PN for UP material is "8300UP042".  
\*Actual width is larger than the nominal width.



**Standard packaging:**  
Belts are supplied in the length requested by the customer.



## SUITABLE FOR CHAINS:

• 8300

## MATERIALS

SPROCKETS: **PA** POLYAMIDE

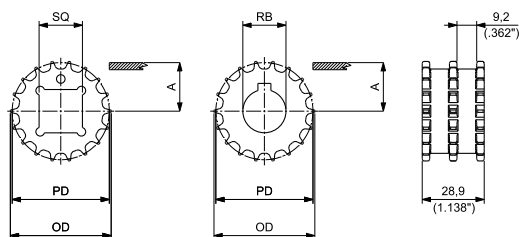

SQUARE BORE - DRIVE/IDLER

ROUND BORE - DRIVE

Matveyor

## MACHINED SOLID DRIVE SPROCKETS

N. TEETH	PITCH DIAMETER PD		OUTSIDE DIAMETER OD		WEAR STRIP POSITIONING A		BORE SIZE*		PART NUMBER		WEIGHT	
	mm	inch	mm	inch	mm	inch	mm	inch**	SQUARE BORE SQ DRIVE/IDLER	ROUND BORE RB DRIVE	Kg	lbs
18	46,07	1.814	47,00	1.850	20,04	0.789	20		<b>MPBAQ83001820</b>	<b>MPBAT83001820</b>	0,03	0.07
							25			<b>MPBAT83001825</b>	0,03	0.07
								¾	<b>MPBAQ830018190</b>	<b>MPBAT830018190</b>	0,03	0.07
								1		<b>MPBAT830018254</b>	0,03	0.07
24	61,29	2.413	62,30	2.453	27,65	1.088	20			<b>MPBAT83002420</b>	0,07	0.15
							25		<b>MPBAQ83002425</b>	<b>MPBAT83002425</b>	0,06	0.13
							30			<b>MPBAT83002430</b>	0,05	0.11
								1	<b>MPBAQ830024254</b>	<b>MPBAT830024254</b>	0,06	0.13
								1¼		<b>MPBAT830024317</b>	0,05	0.11

\*In case of round bore, diameter is indicated. In case of square bore, side of the square is indicated.

\*\* Imperial round bore drive sprockets are supplied with setscrew. Metric round bore drive sprockets are supplied without setscrew.

## SUITABLE FOR CHAINS:

• 8300

### MATERIALS

SPROCKETS:	<b>PA</b>	POLYAMIDE
SCREWS:	<b>SS</b>	STAINLESS STEEL
NUTS:	<b>B</b>	BRASS

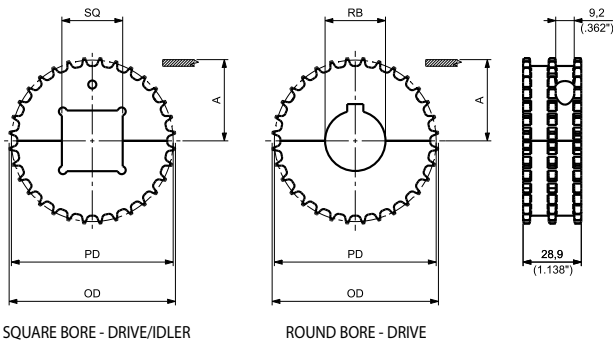
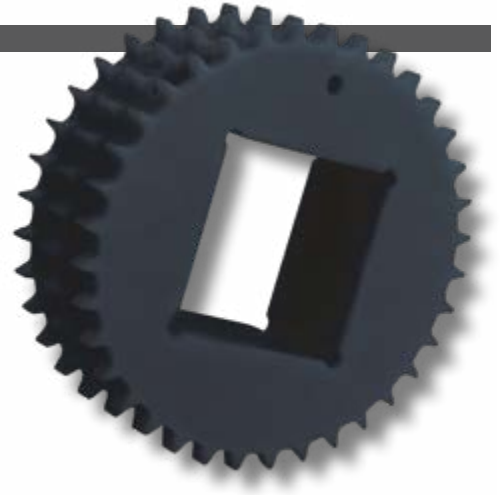

## MACHINED SPLIT DRIVE AND IDLER SPROCKETS

N. TEETH	PITCH DIAMETER PD		OUTSIDE DIAMETER OD		WEAR STRIP POSITIONING A		BORE SIZE*		PART NUMBER		WEIGHT	
	mm	inch	mm	inch	mm	inch	mm	inch**	SQUARE BORE SQ DRIVE/IDLER	ROUND BORE RB DRIVE	Kg	lbs
32	81,59	3.212	82,60	3.252	37,80	1.488	25			<b>MPBAST83003225</b>	0,14	0.31
							30	<b>MPBASQ83003230</b>	<b>MPBAST83003230</b>	0,13	0.29	
							35		<b>MPBAST83003235</b>	0,13	0.29	
							40	<b>MPBASQ83003240</b>	<b>MPBAST83003240</b>	0,12	0.26	
							1		<b>MPBAST830032254</b>	0,14	0.31	
							1¼		<b>MPBAST830032317</b>	0,13	0.29	
36	91,79	3.614	92,70	3.650	42,99	1.692	1½	<b>MPBASQ830032381</b>	<b>MPBAST830032381</b>	0,12	0.26	
							25		<b>MPBAST83003625</b>	0,20	0.44	
							30	<b>MPBASQ83003630</b>	<b>MPBAST83003630</b>	0,19	0.42	
							35		<b>MPBAST83003635</b>	0,18	0.40	
							40	<b>MPBASQ83003640</b>	<b>MPBAST83003640</b>	0,17	0.37	
							1		<b>MPBAST830036254</b>	0,20	0.44	
1¼		<b>MPBAST830036317</b>	0,19	0.42								
1½	<b>MPBASQ830036381</b>	<b>MPBAST830036381</b>	0,18	0.40								

\*In case of round bore, diameter is indicated. In case of square bore, side of the square is indicated.

\*\* Imperial round bore drive sprockets are supplied with setscrew. Metric round bore drive sprockets are supplied without setscrew.



PERFORMANCE IN MOTION

# Matveyor<sup>®</sup>

## 1/2" Pitch Belts and Chains

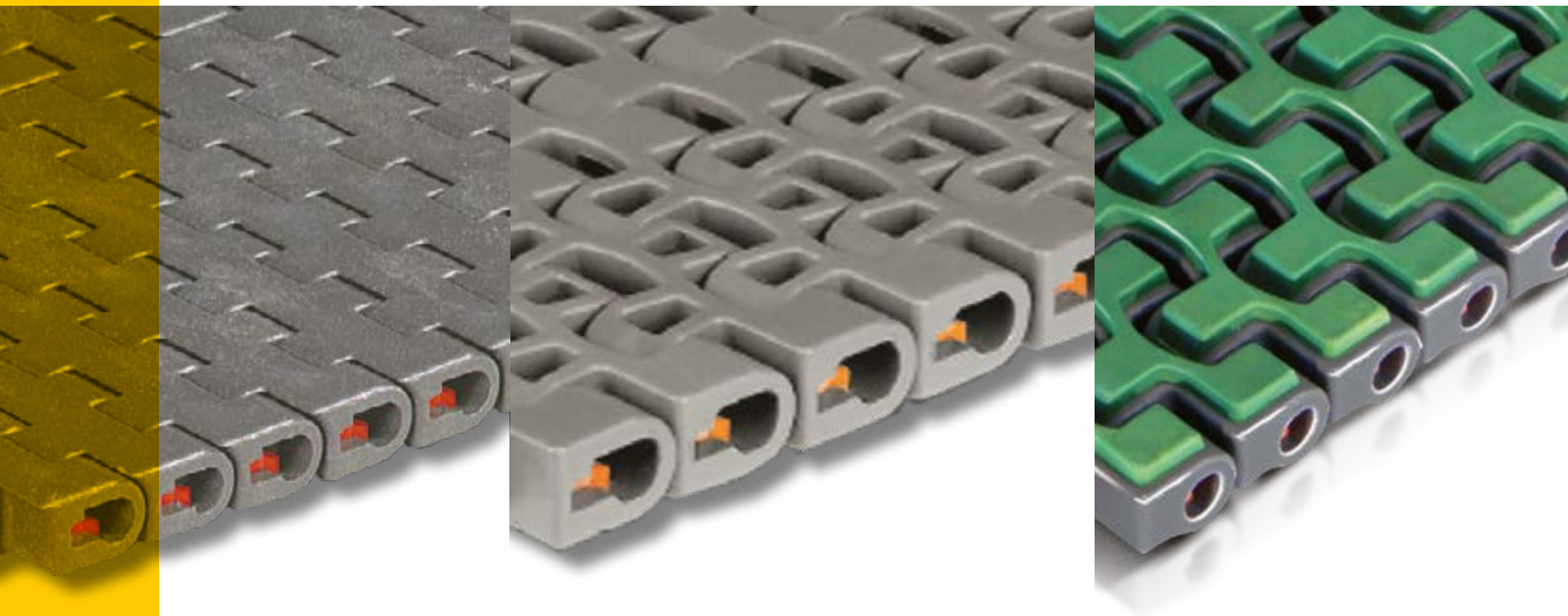

## INDUSTRIES AND APPLICATIONS

Suitable for handling small and unstable products (loose or packaged) in a linear transfer from the head of one conveyor to the next one.

### INDUSTRIES

Bottling and canning  
 Food filling  
 Container manufacturing  
 Pharmaceutical  
 Paper/cardboard  
 Consumer goods

### APPLICATIONS

Depalletizer  
 Mass conveyors  
 Accumulation tables  
 Infeed packaging machines  
 Packaged product convey  
 Product handling within packaging machine (narrow chains)



## REGINA SHORT PITCH (1/2") BELTS

REGINA offers the most complete range of 1/2" pitch belts available on the market, all with 8,7 mm thickness, having the following technical and geometrical features:

- Top surface: solid, rubberized and flush grid.
- Bottom surface: flat (available for metric standard width only) or round.
- Width standard: metric (85 mm width increments) or imperial (3" width increments).
- Tracking guide: belts available with or without tracking guide, depending on the series.

The complete range of REGINA 1/2" pitch belts, together with their geometrical features and available materials is showed in the table below.

SERIES	TOP SURFACE	BOTTOM DESIGN	WIDTH STANDARD	TRACKING GUIDE VERSION		MODULE MATERIAL	RUBBER MATERIAL
				Without	With		
610	Solid	Round	Metric	Available	Available	<b>NEW</b> e-FAST. DK <sup>2</sup> UP PP	
600	Solid	Flat	Metric	Available	Available	e-FAST. DK <sup>2</sup> UP PP	
300	Solid	Round	Imperial	Available	Not available	e-FAST. DK <sup>2</sup> UP PP	
500	Flush Grid	Flat	Metric	Available	Available	UP PP	
200	Flush Grid	Round	Imperial	Available	Not available	UP PP	
HF 510	Rubberized	Round	Metric	Available	Available	UP PP ULF	TPE
HF 200	Rubberized	Round	Imperial	Available	Not available	UP PP	TPE
LBP 610	Rollers	Round	Metric	Available	Available	UP	

## FEATURES

As a complement to its 1/2" pitch modular belts, REGINA proposes a complete range of nose-over transfer components, including static modular nose-over bars and an 8T sprocket, allowing for the following:

- Support products transfer from one conveyor to the next one
- Allow the belt to wrap around a small radius at the head of the conveyor, minimizing the deadplate width

### NOSE-OVER TRANSFER

Exhibit 1 and Exhibit 2 display the minimum recommended center to center distance between head transfer components (nosebar or 8T sprockets), depending on the belt series.

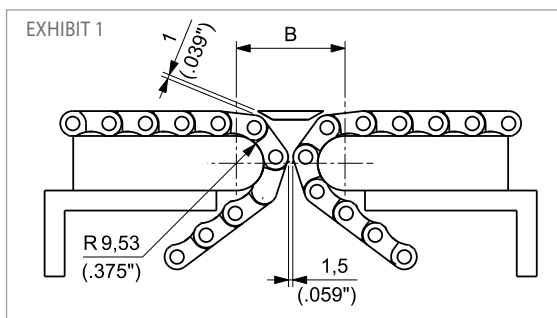

The minimum recommended chordal gap between belt and deadplate is 1 mm (0.039").

BELT SERIES	MINIMUM CENTER TO CENTER DISTANCE B	
	mm	inch
610, 300, 200	37,95	1.494
600, 500	40,76	1.604
HF 510, HF 200	41,95	1.652
LBP 610	57,37	2.258

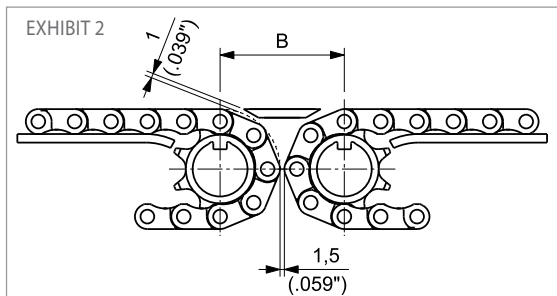

The minimum recommended chordal gap between belt and deadplate is 1 mm (0.039").

BELT SERIES	MINIMUM CENTER TO CENTER DISTANCE B	
	mm	inch
610, 300, 200	43,39	1.708
HF 510, HF 200	47,39	1.866
LBP 610	63,46	2.498

## PRODUCT SELECTION

A critical aspect of choosing a REGINA solid top 1/2" pitch belt is to identify the best belt bottom contour suitable for the application (please refer to Exhibit 3). In particular:

- The round bottom design dramatically reduces the chordal effect when the belt engages with the nose-over bar
  - Such reduction is as high as 89%, from 1,4 mm of the flat-bottom to 0,15 mm of the round-bottom
- The flat bottom design guarantees a continuous contact between belt and wear strips
  - Such contact allows for less specific pressure than round bottom design

EXHIBIT 3 - COMPARISON BETWEEN REGINA SOLID TOP 1/2" PITCH FLAT BOTTOM AND ROUND BOTTOM BELTS DESIGN

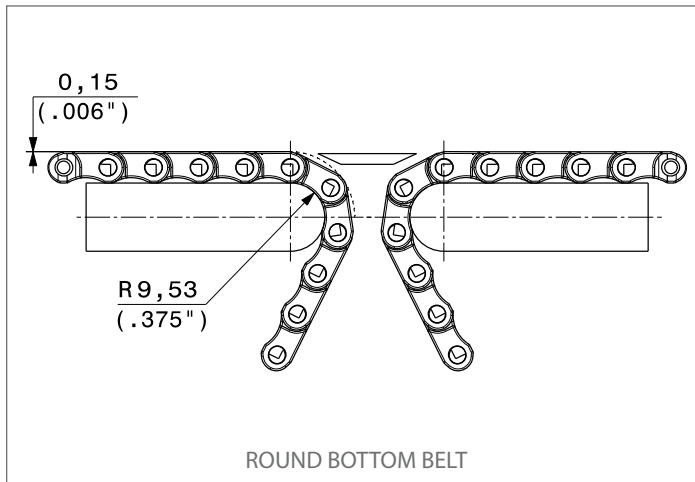
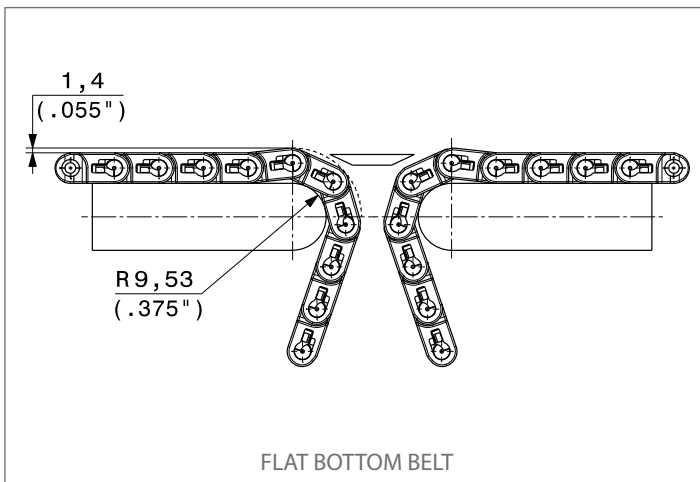

As a consequence:

- Round bottom surface design accomplishes greater product stability during end-to-end transfer.
- Flat bottom surface design minimizes belt wear.



### 8,7 mm (0.343") THICKNESS SOLID TOP

This belt offers a smooth and completely closed surface to provide excellent support and minimize product tipping. Particularly suitable for conveyors where head transfer of products is required.

- **Belt widths:** 85 mm (3.346") or wider in 85 mm (3.346") increments
- **Working Load (at 25°C/77°F):** 14000 N/m (960 lbs/ft) for **UP** and **DK<sup>2</sup>** materials  
10000 N/m (685 lbs/ft) for **PP** material
- **Belt weight:** 9,55 kg/m<sup>2</sup> (1.95 lbs/ft<sup>2</sup>) for **UP** and **DK<sup>2</sup>** materials  
6,46 kg/m<sup>2</sup> (1.32 lbs/ft<sup>2</sup>) for **PP** material



#### VERSION WITHOUT TRACKING GUIDE

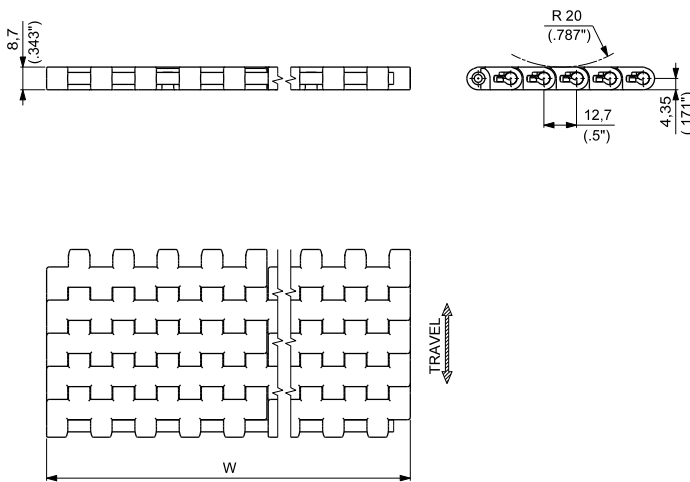

#### VERSION WITH TRACKING GUIDE

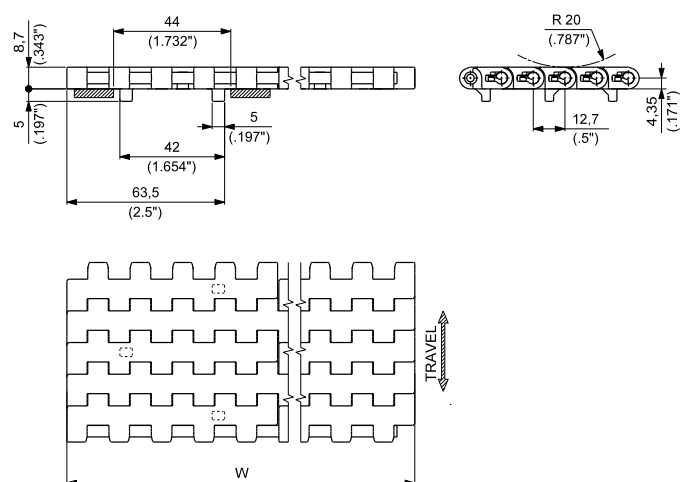

NOTE: The belt is also available with single tracking guide at both belt sides. Please contact REGINA customer service for further information.



Materials see page 12



Nosebar see page 182



Sprockets see pages 189-193



Applications see page 22

WIDTH W		MATERIALS						Pin	
		Module							
		UP ULTRA PERFORMANCE HOMOPOLYMER DELRIN®		DK <sup>2</sup> SPECIAL DELRIN® REINFORCED WITH KEVLAR®		PP SPECIAL POLYPROPYLENE*			
		PART NUMBER		PART NUMBER		PART NUMBER			
mm	inch	WITHOUT TRACKING GUIDE	WITH TRACKING GUIDE	WITHOUT TRACKING GUIDE	WITH TRACKING GUIDE	WITHOUT TRACKING GUIDE	WITH TRACKING GUIDE	POLYPROPYLENE (PBT on request)	
85	3.35	600AUP0085	600AGUP0085	600AD2K0085	600AGD2K0085	600APP0085	600AGPP0085		PBT
170	6.69	600BUP0170	600BG1UP0170	600BD2K0170	600BG1D2K0170	600BPP0170	600BG1PP0170		
255	10.04	600BUP0255	600BG1UP0255	600BD2K0255	600BG1D2K0255	600BPP0255	600BG1PP0255		
340	13.39	600BUP0340	600BG1UP0340	600BD2K0340	600BG1D2K0340	600BPP0340	600BG1PP0340		
425	16.73	600BUP0425	600BG1UP0425	600BD2K0425	600BG1D2K0425	600BPP0425	600BG1PP0425		
510	20.08	600BUP0510	600BG1UP0510	600BD2K0510	600BG1D2K0510	600BPP0510	600BG1PP0510		
595	23.43	600BUP0595	600BG1UP0595	600BD2K0595	600BG1D2K0595	600BPP0595	600BG1PP0595		
680	26.77	600BUP0680	600BG1UP0680	600BD2K0680	600BG1D2K0680	600BPP0680	600BG1PP0680		
765	30.12	600BUP0765	600BG1UP0765	600BD2K0765	600BG1D2K0765	600BPP0765	600BG1PP0765		
850	33.46	600BUP0850	600BG1UP0850	600BD2K0850	600BG1D2K0850	600BPP0850	600BG1PP0850		
935	36.81	600BUP0935	600BG1UP0935	600BD2K0935	600BG1D2K0935	600BPP0935	600BG1PP0935		
1020	40.16	600BUP1020	600BG1UP1020	600BD2K1020	600BG1D2K1020	600BPP1020	600BG1PP1020		

Belts wider than 1020 mm (40.16") are available in 85 mm (3.35") increments.  
To identify the Part Numbers, please substitute the last four digits of the PN with the desired width.  
Example: for a 1105 mm wide belt (=1020+85 mm) without guide, the PN for UP material is "600BUP1105".  
\*Actual width is larger than the nominal width.



Standard packaging:  
Belt widths ≤ 680 mm (26.77") are supplied in rolls of 3,048 m (10 ft) each.  
Belt widths ≥ 765 mm (30.12") are supplied at the length requested by the customer.



### 8,7 mm (0.343") THICKNESS SOLID TOP

This belt offers a smooth and completely closed surface to provide excellent support and minimize product tipping. Particularly suitable for conveyors where head transfer of products is required.

- **Belt widths:** 85 mm (3.346") or wider in 85 mm (3.346") increments
- **Working Load (at 25°C/77°F):** 14000 N/m (960 lbs/ft) for **e-FAST** material
- **Belt weight:** 9,55 kg/m<sup>2</sup> (1.95 lbs/ft<sup>2</sup>) for **e-FAST** material



#### VERSION WITHOUT TRACKING GUIDE

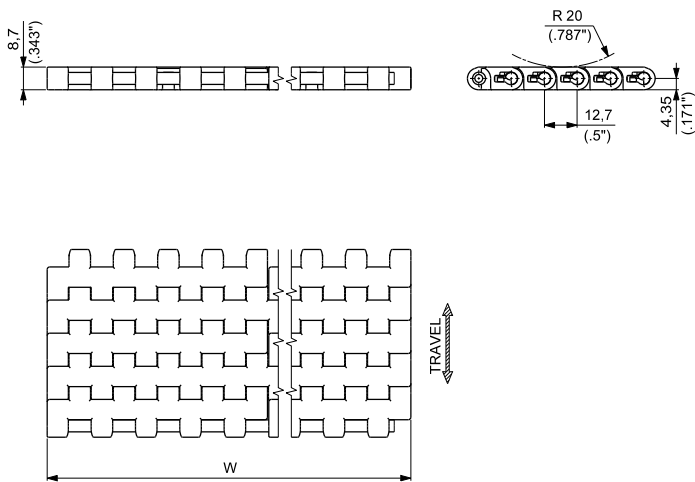

#### VERSION WITH TRACKING GUIDE

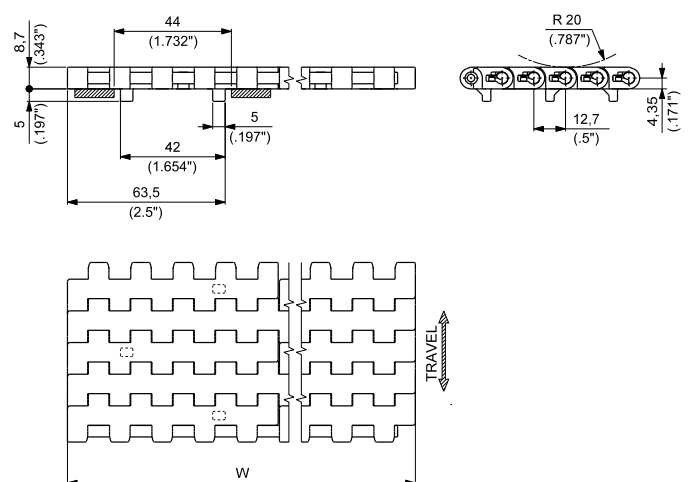

NOTE: The belt is also available with single tracking guide at both belt sides. Please contact REGINA customer service for further information.



Materials  
see page 12



Nosebar  
see page 182



Sprockets  
see pages 189+193



Applications  
see page 22

WIDTH W		MATERIALS		Pin
		e-FAST ECOLOGICAL FRICTION ABATING THERMOPLASTIC		
mm	inch	PART NUMBER		PBT
		WITHOUT TRACKING GUIDE	WITH TRACKING GUIDE	
85	3.35	<b>600AEF0085</b>	<b>600AGEF0085</b>	
170	6.69	<b>600AEF0170</b>	<b>600AG1EF0170</b>	
255	10.04	<b>600AEF0255</b>	<b>600AG1EF0255</b>	
340	13.39	<b>600AEF0340</b>	<b>600AG1EF0340</b>	
425	16.73	<b>600AEF0425</b>	<b>600AG1EF0425</b>	
510	20.08	<b>600AEF0510</b>	<b>600AG1EF0510</b>	
595	23.43	<b>600AEF0595</b>	<b>600AG1EF0595</b>	
680	26.77	<b>600AEF0680</b>	<b>600AG1EF0680</b>	
765	30.12	<b>600AEF0765</b>	<b>600AG1EF0765</b>	
850	33.46	<b>600AEF0850</b>	<b>600AG1EF0850</b>	
935	36.81	<b>600AEF0935</b>	<b>600AG1EF0935</b>	
1020	40.16	<b>600AEF1020</b>	<b>600AG1EF1020</b>	

Belts wider than 1020 mm (40.16") are available in 85 mm (3.35") increments. To identify the Part Numbers, please substitute the last four digits of the PN with the desired width. Example: for a 1105 mm wide belt (=1020+85 mm) without guide, the PN for EF material is "600AEF1105". \*Actual width is larger than the nominal width.



**Standard packaging:**  
Belt widths ≤ 680 mm (26.77") are supplied in rolls of 3,048 m (10 ft) each.  
Belt widths ≥ 765 mm (30.12") are supplied at the length requested by the customer.

## ACTIVE TRANSFER MODULES

### 8,7 mm (0.343") THICKNESS

### SOLID TOP

Active transfer modules 600G ATM series allow the transfer of the products between two 90° conveyor tracks without using dead plates. Left and right version available.

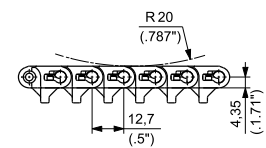
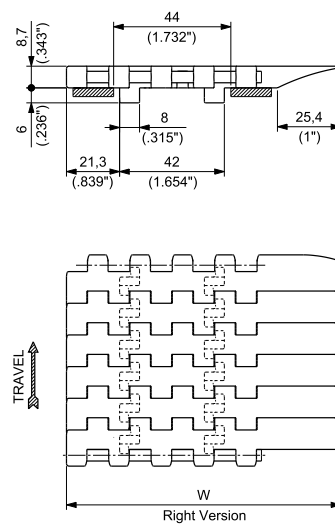
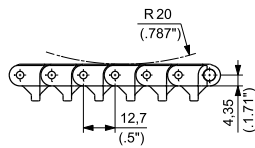
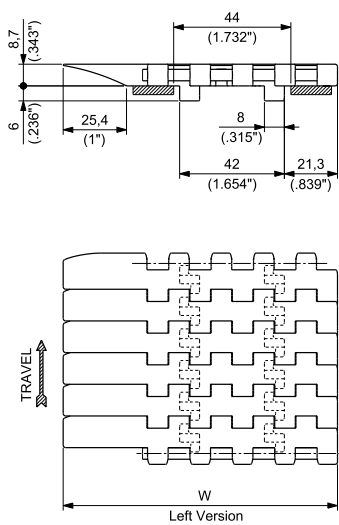

### 600G ATM - Left Version



Materials see page 12



Sprockets see pages 189÷193



Applications see page 22

MATERIALS		ITEM DESCRIPTION	PART NUMBER	WIDTH W		PLATE THICKNESS		WORKING LOAD (25°C/77°F)		WEIGHT	
Plate	Pin			mm	inch	mm	inch	N	lbs	kg/m	lbs/ft
ULTRA PERFORMANCE HOMOPOLYMER DELRIN® <b>UP</b>		600BGATM UP 0085 SX	600BGATMUP085S	110	4.33	8,7	0.343	1190	268	0,96	0.64
POLYPROPYLENE											
SPECIAL DELRIN® REINFORCED WITH KEVLAR® <b>DK2</b>		600BGATM D2K 0085 SX	600BGATMD2K085S	110	4.33	8,7	0.343	1190	268	0,96	0.64

### 600G ATM - Right Version

MATERIALS		ITEM DESCRIPTION	PART NUMBER	WIDTH W		PLATE THICKNESS		WORKING LOAD (25°C/77°F)		WEIGHT	
Plate	Pin			mm	inch	mm	inch	N	lbs	kg/m	lbs/ft
ULTRA PERFORMANCE HOMOPOLYMER DELRIN® <b>UP</b>		600BGATM UP 0085 DX	600BGATMUP085D	110	4.33	8,7	0.343	1190	268	0,96	0.64
POLYPROPYLENE											
SPECIAL DELRIN® REINFORCED WITH KEVLAR® <b>DK2</b>		600BGATM D2K 0085 DX	600BGATMD2K085D	110	4.33	8,7	0.343	1190	268	0,96	0.64



Standard packaging:  
Rolls of 3,048 m (10 feet)

### 8,7 mm (0.343") THICKNESS SOLID TOP

The belt offers a completely closed top surface design for an excellent product support without tipping. The round bottom surface combined with the reduced pitch (1/2") provides the minimum chordal effect for an optimum head transfer of products. Particularly suitable for conveyors where a head transfer of products is required.



- **Belt widths:** 85 mm (3.346") or wider in 85 mm (3.346") increments
- **Working Load (at 25°C/77°F):** 14000 N/m (960 lbs/ft) for **UP** and **DL2** materials  
10000 N/m (685 lbs/ft) for **PP** material
- **Belt weight:** 9,55 kg/m<sup>2</sup> (1.96 lbs/ft<sup>2</sup>) for **UP** and **DL2** materials  
6,46 kg/m<sup>2</sup> (1.32 lbs/ft<sup>2</sup>) for **PP** material

#### VERSION WITHOUT TRACKING GUIDE

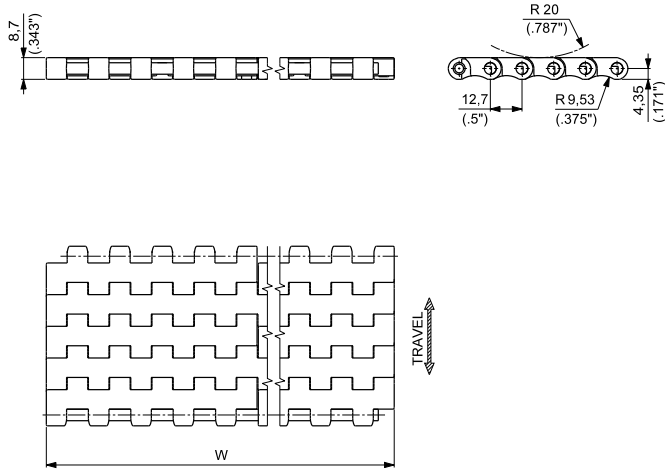

#### VERSION WITH TRACKING GUIDE

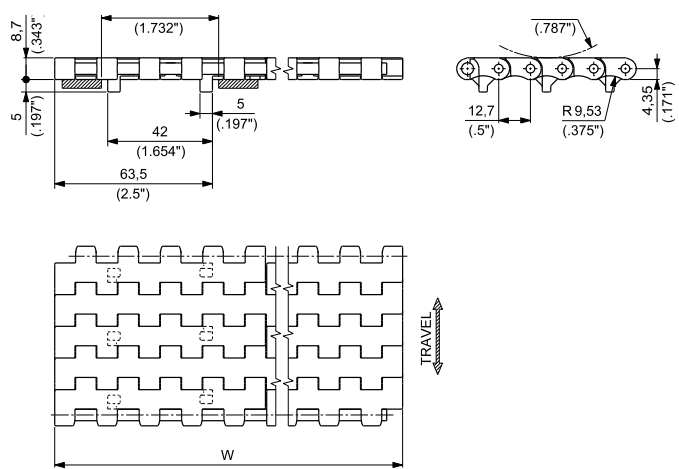

Materials  
see page 12



Nosebar  
see page 182



Sprockets  
see pages 189÷193



Applications  
see page 22

WIDTH W		MATERIALS						Pin
		Module						
		UP ULTRA PERFORMANCE HOMOPOLYMER DELRIN®		DL2 SPECIAL DELRIN® REINFORCED WITH KEVLAR®		PP SPECIAL POLYPROPYLENE*		
PART NUMBER		PART NUMBER		PART NUMBER		PBT		
mm	inch	WITHOUT TRACKING GUIDE	WITH TRACKING GUIDE	WITHOUT TRACKING GUIDE	WITH TRACKING GUIDE		WITHOUT TRACKING GUIDE	WITH TRACKING GUIDE
85	3.35	610AUP0085	610AGUP0085	610AD2K0085	610AGD2K0085		610APP0085	610AGPP0085
170	6.69	610BUP0170	610BG1UP0170	610BD2K0170	610BG1D2K0170	610BPP0170	610BG1PP0170	POLYPROPYLENE (PBT on request)
255	10.04	610BUP0255	610BG1UP0255	610BD2K0255	610BG1D2K0255	610BPP0255	610BG1PP0255	
340	13.39	610BUP0340	610BG1UP0340	610BD2K0340	610BG1D2K0340	610BPP0340	610BG1PP0340	
425	16.73	610BUP0425	610BG1UP0425	610BD2K0425	610BG1D2K0425	610BPP0425	610BG1PP0425	
510	20.08	610BUP0510	610BG1UP0510	610BD2K0510	610BG1D2K0510	610BPP0510	610BG1PP0510	
595	23.43	610BUP0595	610BG1UP0595	610BD2K0595	610BG1D2K0595	610BPP0595	610BG1PP0595	
680	26.77	610BUP0680	610BG1UP0680	610BD2K0680	610BG1D2K0680	610BPP0680	610BG1PP0680	
765	30.12	610BUP0765	610BG1UP0765	610BD2K0765	610BG1D2K0765	610BPP0765	610BG1PP0765	
850	33.46	610BUP0850	610BG1UP0850	610BD2K0850	610BG1D2K0850	610BPP0850	610BG1PP0850	
935	36.81	610BUP0935	610BG1UP0935	610BD2K0935	610BG1D2K0935	610BPP0935	610BG1PP0935	
1020	40.16	610BUP1020	610BG1UP1020	610BD2K1020	610BG1D2K1020	610BPP1020	610BG1PP1020	

Belts wider than 1020 mm (40.16") are available in 85 mm (3.35") increments.  
To identify the Part Numbers, please substitute the last four digits of the PN with the desired width.  
Example: for a 1105 mm wide belt (=1020+85 mm) without guide, the PN for UP material is "610BUP1105".  
\*Actual width is larger than the nominal width.



**Standard packaging:**  
Belt widths ≤ 680 mm (26.77") are supplied in rolls of 3,048 m (10 ft) each.  
Belt widths ≥ 765 mm (30.12") are supplied in the length requested by the customer.

### 8,7 mm (0.343") THICKNESS SOLID TOP

The belt offers a completely closed top surface design for an excellent product support without tipping. The round bottom surface combined to the reduced pitch (1/2") provides the minimum chordal effect for an optimum head transfer of products. Particularly suitable for conveyors where a head transfer of products is required.



- **Belt widths:** 85 mm (3.346") or wider in 85 mm (3.346") increments
- **Working Load (at 25°C/77°F):** 14000 N/m (960 lbs/ft) for **E-F.A.S.T.** material
- **Belt weight:** 9,55 kg/m<sup>2</sup> (1.95 lbs/ft<sup>2</sup>) for **E-F.A.S.T.** material

#### VERSION WITHOUT TRACKING GUIDE

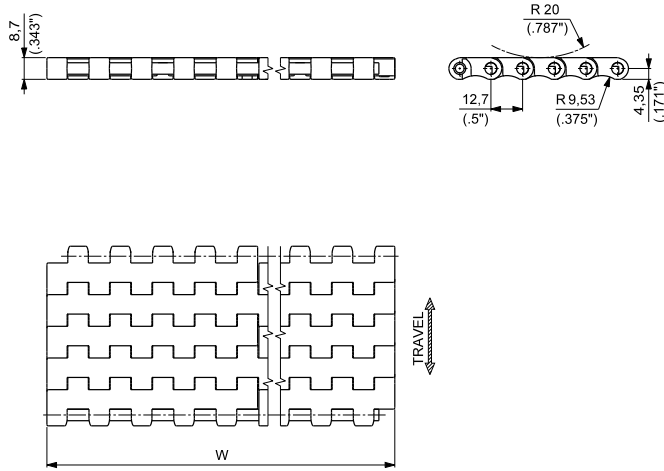

#### VERSION WITH TRACKING GUIDE

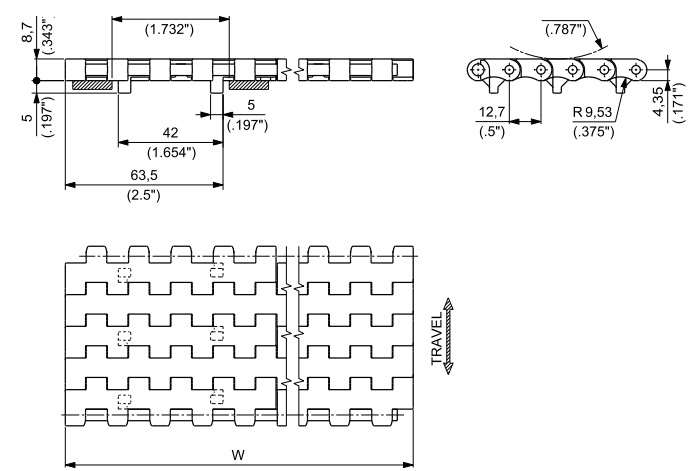

Materials see page 12



Nosebar see page 182



Sprockets see pages 189-193



Applications see page 22

WIDTH W		MATERIALS		
		E-F.A.S.T. ECOLOGICAL FRICTION ABATING THERMOPLASTIC		
		PART NUMBER		Pin
mm	inch	WITHOUT TRACKING GUIDE	WITH TRACKING GUIDE	
85	3.35	<b>610AEF0085</b>	<b>610AGEF0085</b>	PBT
170	6.69	<b>610AEF0170</b>	<b>610AG1EF0170</b>	
255	10.04	<b>610AEF0255</b>	<b>610AG1EF0255</b>	
340	13.39	<b>610AEF0340</b>	<b>610AG1EF0340</b>	
425	16.73	<b>610AEF0425</b>	<b>610AG1EF0425</b>	
510	20.08	<b>610AEF0510</b>	<b>610AG1EF0510</b>	
595	23.43	<b>610AEF0595</b>	<b>610AG1EF0595</b>	
680	26.77	<b>610AEF0680</b>	<b>610AG1EF0680</b>	
765	30.12	<b>610AEF0765</b>	<b>610AG1EF0765</b>	
850	33.46	<b>610AEF0850</b>	<b>610AG1EF0850</b>	
935	36.81	<b>610AEF0935</b>	<b>610AG1EF0935</b>	
1020	40.16	<b>610AEF1020</b>	<b>610AG1EF1020</b>	

Belts wider than 1020 mm (40.16") are available in 85 mm (3.35") increments.  
To identify the Part Numbers, please substitute the last four digits of the PN with the desired width.  
Example: for a 1105 mm wide belt (=1020+85 mm) without guide, the PN for EF material is "610AEF1105".  
\*Actual width is larger than the nominal width.



**Standard packaging:**  
Belt widths ≤ 680 mm (26.77") are supplied in rolls of 3,048 m (10 ft) each.  
Belt widths ≥ 765 mm (30.12") are supplied in the length requested by the customer.

## 8,7 mm (0.343") THICKNESS FLUSH GRID

Excellent combination of support and open area (21%).  
Optimum drainage of liquids and good support of the conveyed products.  
Particularly suitable for conveyors where the head transfer of products is required.

- **Belt widths:** 85 mm (3.346") or wider in 85 mm (3.346") increments
- **Working Load (at 25°C/77°F):** 14000 N/m (960 lbs/ft) for **UP** material  
10000 N/m (685 lbs/ft) for **PP** material
- **Belt weight:** 7,06 kg/m<sup>2</sup> (1.45 lbs/ft<sup>2</sup>) for **UP** material  
4,76 kg/m<sup>2</sup> (0.97 lbs/ft<sup>2</sup>) for **PP** material



### VERSION WITHOUT TRACKING GUIDE

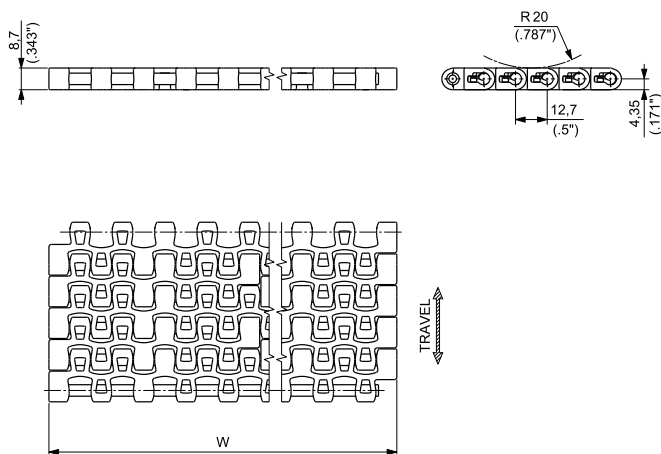

### VERSION WITH TRACKING GUIDE

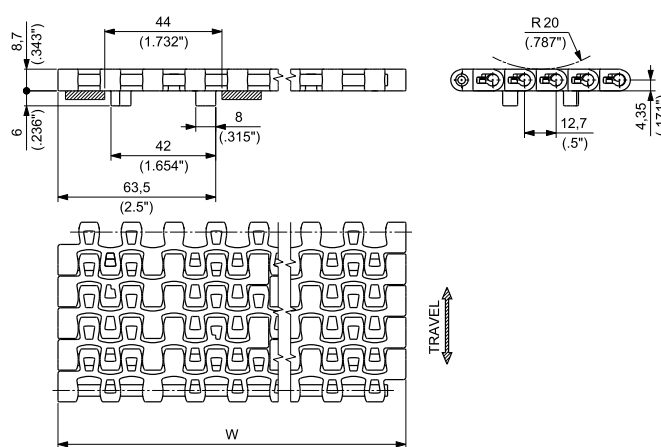

NOTE: The belt is also available with single tracking guide at both belt sides. Please contact REGINA customer service for further information.



Materials  
see page 12



Nosebar  
see page 182



Sprockets  
see pages 189-193



Applications  
see page 22

WIDTH W		MATERIALS				Pin
		Module		Pin		
mm	inch	<b>UP</b> ULTRA PERFORMANCE HOMOPOLYMER DELRIN®	<b>PP</b> SPECIAL POLYPROPYLENE*			
		PART NUMBER		PART NUMBER		
		WITHOUT TRACKING GUIDE	WITH TRACKING GUIDE	WITHOUT TRACKING GUIDE	WITH TRACKING GUIDE	
85	3.35	<b>500AUP0085</b>	<b>500AGUP0085</b>	<b>500APP0085</b>	<b>500AGPP0085</b>	PBT
170	6.69	<b>500BUP0170</b>	<b>500BG1UP0170</b>	<b>500BPP0170</b>	<b>500BG1PP0170</b>	POLYPROPYLENE (PBT on request)
255	10.04	<b>500BUP0255</b>	<b>500BG1UP0255</b>	<b>500BPP0255</b>	<b>500BG1PP0255</b>	
340	13.39	<b>500BUP0340</b>	<b>500BG1UP0340</b>	<b>500BPP0340</b>	<b>500BG1PP0340</b>	
425	16.73	<b>500BUP0425</b>	<b>500BG1UP0425</b>	<b>500BPP0425</b>	<b>500BG1PP0425</b>	
510	20.08	<b>500BUP0510</b>	<b>500BG1UP0510</b>	<b>500BPP0510</b>	<b>500BG1PP0510</b>	
595	23.43	<b>500BUP0595</b>	<b>500BG1UP0595</b>	<b>500BPP0595</b>	<b>500BG1PP0595</b>	
680	26.77	<b>500BUP0680</b>	<b>500BG1UP0680</b>	<b>500BPP0680</b>	<b>500BG1PP0680</b>	
765	30.12	<b>500BUP0765</b>	<b>500BG1UP0765</b>	<b>500BPP0765</b>	<b>500BG1PP0765</b>	
850	33.46	<b>500BUP0850</b>	<b>500BG1UP0850</b>	<b>500BPP0850</b>	<b>500BG1PP0850</b>	
935	36.81	<b>500BUP0935</b>	<b>500BG1UP0935</b>	<b>500BPP0935</b>	<b>500BG1PP0935</b>	
1020	40.16	<b>500BUP1020</b>	<b>500BG1UP1020</b>	<b>500BPP1020</b>	<b>500BG1PP1020</b>	

Belts wider than 1020 mm (40.16") are available in 85 mm (3.35") increments.  
To identify the Part Numbers, please substitute the last four digits of the PN with the desired width.  
Example: for a 1105 mm wide belt (=1020+85 mm) without guide, the PN for UP material is "500BUP1105".  
\*Actual width is larger than the nominal width.



**Standard packaging:**  
Belt widths ≤ 680 mm (26.77") are supplied in rolls of 3,048 m (10 ft) each.  
Belt widths ≥ 765 mm (30.12") are supplied in the length requested by the customer.



### 8,7 mm (0.343") THICKNESS RUBBERIZED SURFACE

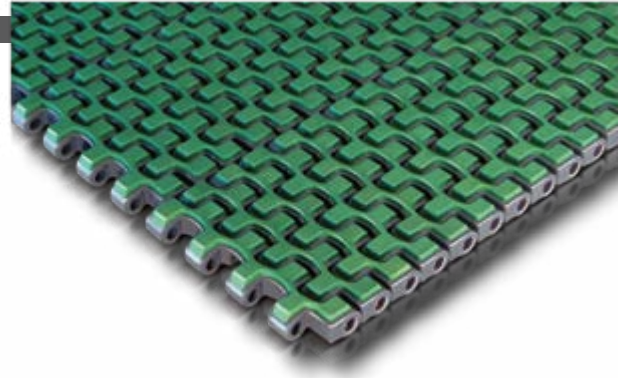

Belt designed for handling packed containers like boxes, multi packs and cases in packaging lines. It is the optimal solution for high speed stop belts, metering belts, etc. The rubberized area is maximized, both in the transversal and longitudinal direction, reducing gaps between the rubber pads.

- **Belt widths:** 85 mm (3.346") or wider in 85 mm (3.346") increments
- **Working Load (at 25°C/77°F):** 14000 N/m (960 lbs/ft) for **ULF** material
- **Belt weight:** 9,14 kg/m<sup>2</sup> (1.87 lbs/ft<sup>2</sup>) for **ULF** material

#### VERSION WITHOUT TRACKING GUIDE

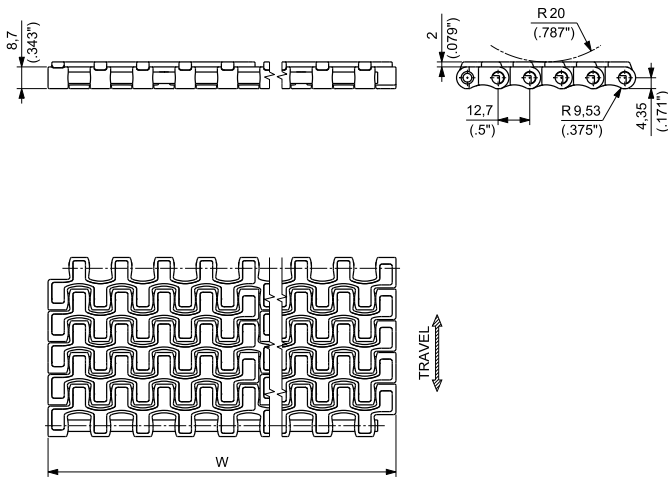

#### VERSION WITH TRACKING GUIDE

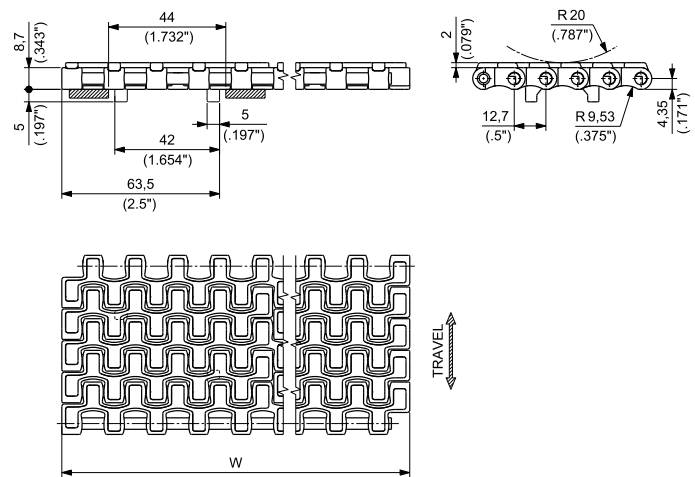

NOTE: The belt is also available with single tracking guide at both belt sides. Please contact REGINA customer service for further information.



Materials  
see page 12



Nosebar  
see page 182



Sprockets  
see pages 189÷193



Applications  
see page 22

WIDTH W		MATERIALS		
		Module	Rubber	Pin
		<b>ULF</b>	ULTRA LOW FRICTION POLYESTER RESIN	
		PART NUMBER		
mm	inch	WITHOUT TRACKING GUIDE	WITH TRACKING GUIDE	
85	3.35	<b>HF510ULF0085</b>	<b>HF510GULF0085</b>	THERMOPLASTIC <b>TPE</b> Hardness: 55 ShA
170	6.69	<b>HF510ULF0170</b>	<b>HF510G1ULF0170</b>	
255	10.04	<b>HF510ULF0255</b>	<b>HF510G1ULF0255</b>	
340	13.39	<b>HF510ULF0340</b>	<b>HF510G1ULF0340</b>	
425	16.73	<b>HF510ULF0425</b>	<b>HF510G1ULF0425</b>	
510	20.08	<b>HF510ULF0510</b>	<b>HF510G1ULF0510</b>	
595	23.43	<b>HF510ULF0595</b>	<b>HF510G1ULF0595</b>	
680	26.77	<b>HF510ULF0680</b>	<b>HF510G1ULF0680</b>	
765	30.12	<b>HF510ULF0765</b>	<b>HF510G1ULF0765</b>	
850	33.46	<b>HF510ULF0850</b>	<b>HF510G1ULF0850</b>	
935	36.81	<b>HF510ULF0935</b>	<b>HF510G1ULF0935</b>	
1020	40.16	<b>HF510ULF1020</b>	<b>HF510G1ULF1020</b>	

Belts wider than 1020 mm (40.16") are available in 85 mm (3.35") increments.  
To identify the Part Numbers, please substitute the last four digits of the PN with the desired width.  
Example: for a 1105 mm wide belt (=1020+85 mm) without guide, the PN is "HF510ULF1105".  
For HF 510 belts in PP material see next page.



**Standard packaging:**  
Belt widths ≤ 170 mm (6.63") are supplied in rolls of 3,048 m (10 ft) each.  
Belt widths ≥ 255 mm (10.04") and ≤ 425 mm (16.73") are supplied in rolls of 1,524 m (5 ft) each.  
Belt widths ≥ 510 mm (20.08") are supplied in the length requested by the customer.



### 8,7 mm (0.343") THICKNESS RUBBERIZED SURFACE

Belt designed for handling packed containers like boxes, multi packs and cases in packaging lines. It is the optimal solution for high speed stop belts, metering belts, etc. The rubberized area is maximized, both in the transversal and longitudinal direction, reducing gaps between the rubber pads.

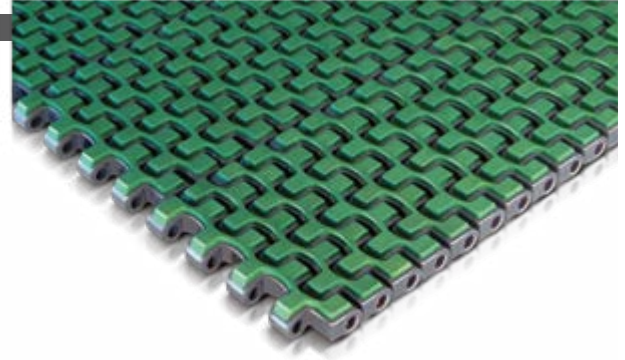

- **Belt widths:** 85 mm (3.346") or wider in 85 mm (3.346") increments
- **Working Load (at 25°C/77°F):** 10000 N/m (685 lbs/ft) for **PP** material
- **Belt weight:** 7,47 kg/m<sup>2</sup> (1.53 lbs/ft<sup>2</sup>) for **PP** material

#### VERSION WITHOUT TRACKING GUIDE

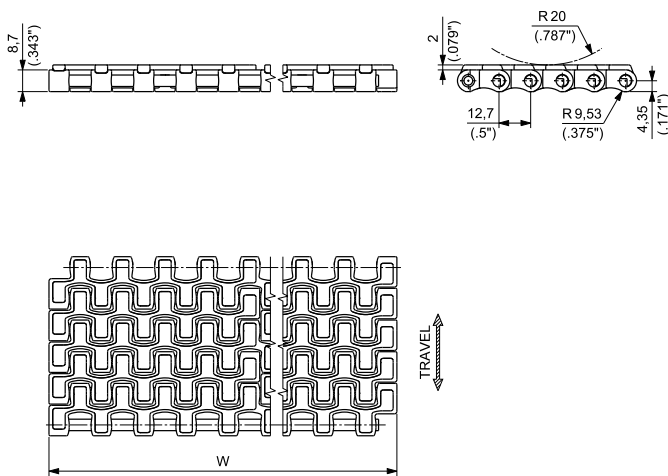

#### VERSION WITH TRACKING GUIDE

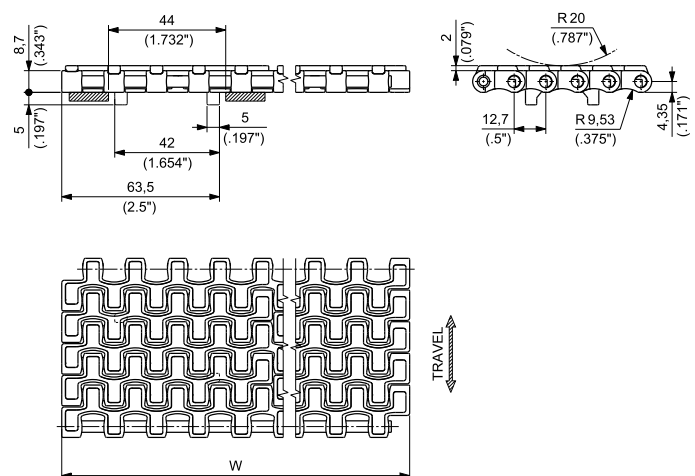

NOTE: The belt is also available with single tracking guide at both belt sides. Please contact REGINA customer service for further information.



Materials  
see page 12



Nosebar  
see page 182



Sprockets  
see pages 189-193



Applications  
see page 22

WIDTH W		Module SPECIAL PP POLYPROPYLENE*		Rubber	Pin
		PART NUMBER		THERMOPLASTIC TPE Hardness: 50 ShA	PBT
mm	inch	WITHOUT TRACKING GUIDE	WITH TRACKING GUIDE		
85	3.35	<b>HF510APP0085</b>	<b>HF510AGPP0085</b>		
170	6.69	<b>HF510APP0170</b>	<b>HF510AG1PP0170</b>		
255	10.04	<b>HF510APP0255</b>	<b>HF510AG1PP0255</b>		
340	13.39	<b>HF510APP0340</b>	<b>HF510AG1PP0340</b>		
425	16.73	<b>HF510APP0425</b>	<b>HF510AG1PP0425</b>		
510	20.08	<b>HF510APP0510</b>	<b>HF510AG1PP0510</b>		
595	23.43	<b>HF510APP0595</b>	<b>HF510AG1PP0595</b>		
680	26.77	<b>HF510APP0680</b>	<b>HF510AG1PP0680</b>		
765	30.12	<b>HF510APP0765</b>	<b>HF510AG1PP0765</b>		
850	33.46	<b>HF510APP0850</b>	<b>HF510AG1PP0850</b>		
935	36.81	<b>HF510APP0935</b>	<b>HF510AG1PP0935</b>		
1020	40.16	<b>HF510APP1020</b>	<b>HF510AG1PP1020</b>		

Belts wider than 1020 mm (40.16") are available in 85 mm (3.35") increments.  
To identify the Part Numbers, please substitute the last four digits of the PN with the desired width.  
Example: for a 1105 mm wide belt (=1020+85 mm) without guide, the PN for PP material is "HF510APP1105".  
\*Actual width is larger than the nominal width.  
For HF 510 belts in ULF material see previous page.



**Standard packaging:**  
Belt widths ≤ 170 mm (6.63") are supplied in rolls of 3,048 m (10 ft) each.  
Belt widths ≥ 255 mm (10.04") and ≤ 425 mm (16.73") are supplied in rolls of 1,524 m (5 ft) each.  
Belt widths ≥ 510 mm (20.08") are supplied in the length requested by the customer.

### 8,7 mm (0.343") THICKNESS LBP ROLLERS

**NEW**



Designed for accumulating applications where efficient nose-over transfer is required. The round bottom surface, combined with the 1/2" pitch, provides the minimum chordal effect minimizing dead plates.

- **Belt widths:** 85 mm (3.346") or wider in 85 mm (3.346") increments
- **Working Load (at 25°C/77°F):** 27000 N/m (1,850 lbs/ft)
- **Belt weight:** 18,3 kg/m<sup>2</sup> (3.75 lbs/ft<sup>2</sup>)

#### VERSION WITHOUT TRACKING GUIDE

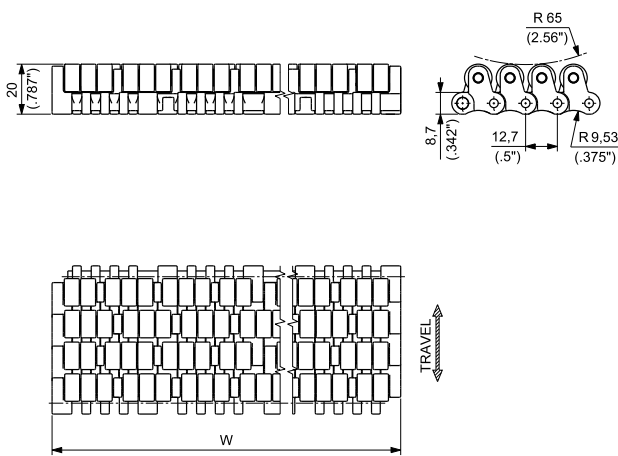

#### VERSION WITH TRACKING GUIDE

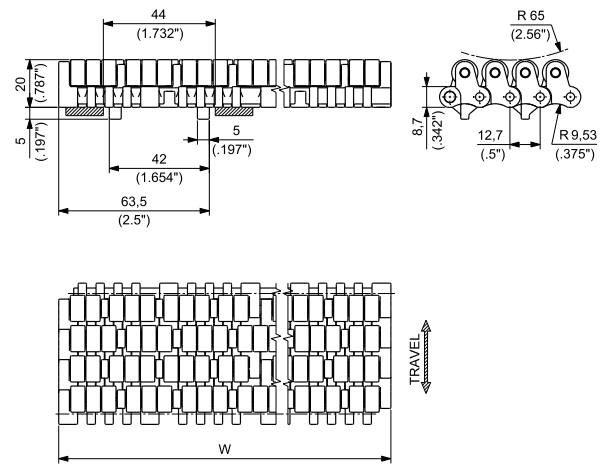

Materials see page 12



Nosebar see page 182



Sprockets see pages 189-193



Applications see page 22

WIDTH W		MATERIALS		
		Module and Roller		Pin
		UP	ULTRA PERFORMANCE HOMOPOLYMER DELRIN®	
		PART NUMBER		PBT
mm	inch	WITHOUT TRACKING GUIDE	WITH TRACKING GUIDE	
85	3.35	<b>LBP610AUP0085</b>	<b>LBP610AGUP0085</b>	
170	6.69	<b>LBP610AUP0170</b>	<b>LBP610AG1UP0170</b>	
255	10.04	<b>LBP610AUP0255</b>	<b>LBP610AG1UP0255</b>	
340	13.39	<b>LBP610AUP0340</b>	<b>LBP610AG1UP0340</b>	
425	16.73	<b>LBP610AUP0425</b>	<b>LBP610AG1UP0425</b>	
510	20.08	<b>LBP610AUP0510</b>	<b>LBP610AG1UP0510</b>	
595	23.43	<b>LBP610AUP0595</b>	<b>LBP610AG1UP0595</b>	
680	26.77	<b>LBP610AUP0680</b>	<b>LBP610AG1UP0680</b>	
765	30.12	<b>LBP610AUP0765</b>	<b>LBP610AG1UP0765</b>	
850	33.46	<b>LBP610AUP0850</b>	<b>LBP610AG1UP0850</b>	
935	36.81	<b>LBP610AUP0935</b>	<b>LBP610AG1UP0935</b>	
1020	40.16	<b>LBP610AUP1020</b>	<b>LBP610AG1UP1020</b>	

Belts wider than 1020 mm (40.16") are available in 85 mm (3.35") increments. To identify the Part Numbers, please substitute the last four digits of the PN with the desired width. Example: for a 1105 mm wide belt (=1020+85 mm) without guide, the PN is "LBP610AUP1105".



**Standard packaging:**  
 Belt widths ≤ 680 mm (26.77") are supplied in rolls of 1,524 m (5 ft) each.  
 Belt widths ≥ 765 mm (30.12") and ≤ 935 mm (36.81") are supplied in rolls of 1,016 m (3.33 ft) each.  
 Belt widths ≥ 1020 mm (40.16") are supplied in the length requested by the customer.

### 8,7 mm (0.343") THICKNESS SOLID TOP

The belt offers a completely closed top surface design for an excellent product support without tipping. The round bottom surface combined with the reduced pitch (1/2") transfer of products provides the minimal chordal effect for an optimum head transfer of products.

- **Belt widths:** 114,3 mm (4 1/2"), 76,2 mm (3") or wider in 76,2 mm (3") increments
- **Working Load (at 25°C/77°F):** 14000 N/m (960 lbs/ft) for **UP**, **DK2** and **e-F.A.S.T.** materials  
10000 N/m (685 lbs/ft) for **PP** materials
- **Belt weight:** 9,52 kg/m<sup>2</sup> (1.95 lbs/ft<sup>2</sup>) for **UP**, **DK2** and **e-F.A.S.T.** materials  
6,55 kg/m<sup>2</sup> (1.34 lbs/ft<sup>2</sup>) for **PP** material

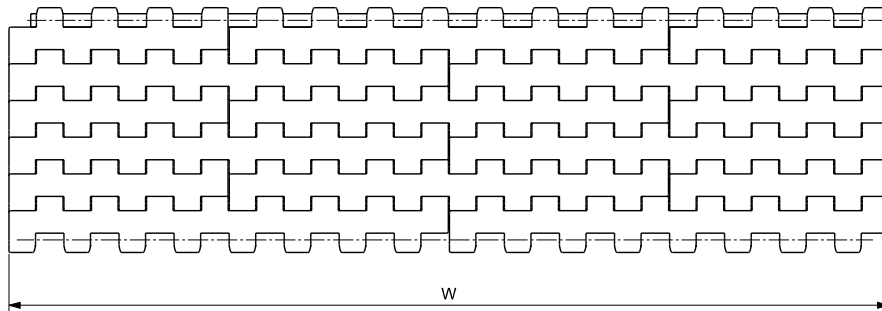
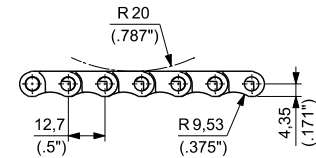

Materials see page 12



Nosebar see page 182



Sprockets see pages 189÷193



Applications see page 22

WIDTH W		MATERIALS				Pin
		Module				
mm	inch	<b>UP</b> ULTRA PERFORMANCE HOMOPOLYMER DELRIN®	<b>DK2</b> SPECIAL DELRIN® REINFORCED WITH KEVLAR®	<b>PP</b> SPECIAL POLYPROPYLENE*	<b>e-F.A.S.T.</b> ECOLOGICAL FRICTION ABATING THERMOPLASTIC	PBT
		PART NUMBER	PART NUMBER	PART NUMBER	PART NUMBER	
114,3	4.5	<b>300AUPKG/000</b>	<b>300AD2KKG/000</b>	<b>300APPKG/000</b>	<b>300AEFKG/000</b>	PBT for e-F.A.S.T. material POLYPROPYLENE for all other materials (PBT on request for all other materials)
76,2	3	<b>300BUP003</b>	<b>300BD2K003</b>	<b>300BPP003</b>	<b>300AEF003</b>	
152,4	6	<b>300BUP006</b>	<b>300BD2K006</b>	<b>300BPP006</b>	<b>300AEF006</b>	
228,6	9	<b>300BUP009</b>	<b>300BD2K009</b>	<b>300BPP009</b>	<b>300AEF009</b>	
304,8	12	<b>300BUP012</b>	<b>300BD2K012</b>	<b>300BPP012</b>	<b>300AEF012</b>	
381,0	15	<b>300BUP015</b>	<b>300BD2K015</b>	<b>300BPP015</b>	<b>300AEF015</b>	
457,2	18	<b>300BUP018</b>	<b>300BD2K018</b>	<b>300BPP018</b>	<b>300AEF018</b>	
533,4	21	<b>300BUP021</b>	<b>300BD2K021</b>	<b>300BPP021</b>	<b>300AEF021</b>	
609,6	24	<b>300BUP024</b>	<b>300BD2K024</b>	<b>300BPP024</b>	<b>300AEF024</b>	
685,8	27	<b>300BUP027</b>	<b>300BD2K027</b>	<b>300BPP027</b>	<b>300AEF027</b>	
762,0	30	<b>300BUP030</b>	<b>300BD2K030</b>	<b>300BPP030</b>	<b>300AEF030</b>	
838,2	33	<b>300BUP033</b>	<b>300BD2K033</b>	<b>300BPP033</b>	<b>300AEF033</b>	
914,4	36	<b>300BUP036</b>	<b>300BD2K036</b>	<b>300BPP036</b>	<b>300AEF036</b>	
990,6	39	<b>300BUP039</b>	<b>300BD2K039</b>	<b>300BPP039</b>	<b>300AEF039</b>	

Belts wider than 990,6 mm (39") are available in 76,2 (3") increments.  
To identify the Part Numbers, please substitute the last three digits of the PN with the desired width.  
Example: for a 42" wide belt (=39+3 inches), the PN for UP material is "300BUP042".  
\*Actual width is larger than the nominal width.



Standard packaging:  
114,3 mm (4.5") wide belt is supplied in rolls of 3,048 m (10ft) each.  
Other belt widths are supplied in the length requested by the customer.

### ACTIVE TRANSFER MODULES 8,7 mm (0.343") THICKNESS SOLID TOP

Active transfer modules 300G ATM series allow the transfer of the products between two 90° conveyor tracks without using dead plates. Left and right version in available.

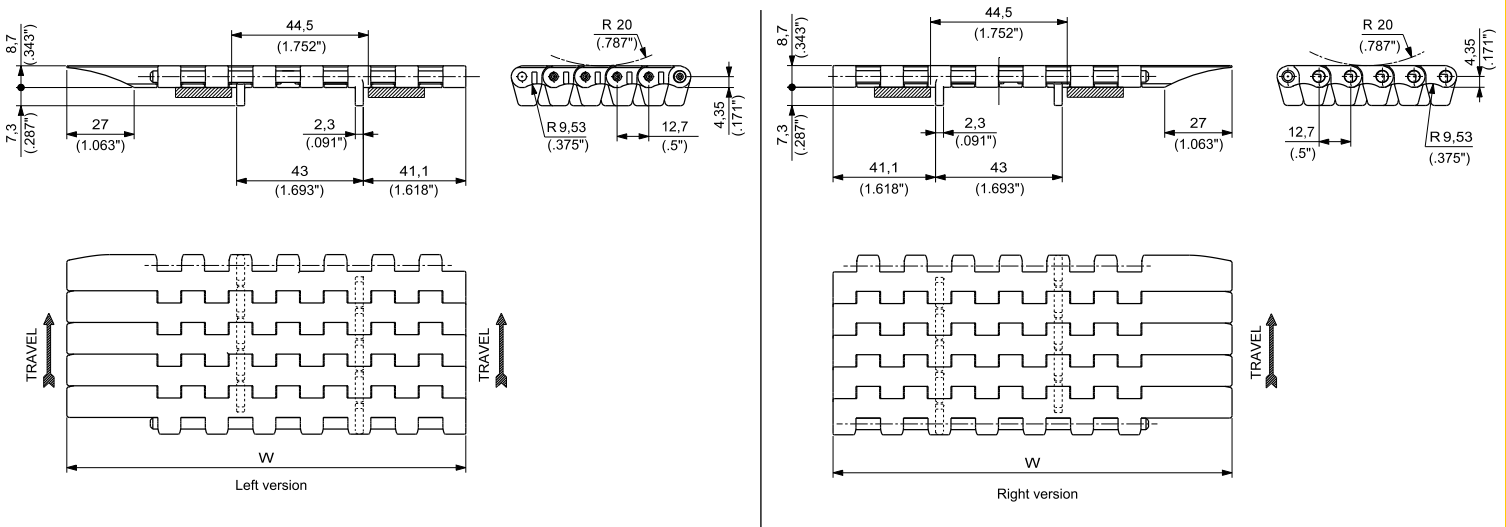

#### 300G ATM - Left Version



Materials see page 12



Sprockets see pages 189÷193



Applications see page 22

MATERIALS		ITEM DESCRIPTION	PART NUMBER	WIDTH W		PLATE THICKNESS		WORKING LOAD (25°C/77°F)		WEIGHT	
Plate	Pin			mm	inch	mm	inch	N	lbs	kg/m	lbs/ft
ULTRA PERFORMANCE HOMOPOLYMER DELRIN® <b>UP</b>	PBT	300AGATM UP 450 SX	300AGATMUP450LH	160	6.30	8,7	0.343	1190	268	1,42	0.95
SPECIAL DELRIN® REINFORCED WITH KEVLAR® <b>DK2</b>		300AGATM D2K 450 SX	300AGATMD2K450LH	160	6.30	8,7	0.343	1190	268	1,42	0.95

#### 300G ATM - Right Version

MATERIALS		ITEM DESCRIPTION	PART NUMBER	WIDTH W		PLATE THICKNESS		WORKING LOAD (25°C/77°F)		WEIGHT	
Plate	Pin			mm	inch	mm	inch	N	lbs	kg/m	lbs/ft
ULTRA PERFORMANCE HOMOPOLYMER DELRIN® <b>UP</b>	PBT	300AGATM UP 450 DX	300AGATMUP450RH	160	6.30	8,7	0.343	1190	268	1,42	0.95
SPECIAL DELRIN® REINFORCED WITH KEVLAR® <b>DK2</b>		300AGATM D2K 450 DX	300AGATMD2K450RH	160	6.30	8,7	0.343	1190	268	1,42	0.95



Standard packaging: Rolls of 3,048 m (10 feet)

### 8,7 mm (0.343") THICKNESS FLUSH GRID

The belt offers an excellent combination of support and open area for optimal liquid and air flow-through where frequent cleaning is required.



- **Belt widths:** 76,2 mm (3") or wider in 76,2 mm (3") increments
- **Working Load (at 25°C/77°F):** 14000 N/m (960 lbs/ft) for **UP** material  
10000 N/m (685 lbs/ft) for **PP** material
- **Belt weight:** 7,60 kg/m<sup>2</sup> (1.56 lbs/ft<sup>2</sup>) for **UP** material  
5,44 kg/m<sup>2</sup> (1.11 lbs/ft<sup>2</sup>) for **PP** material

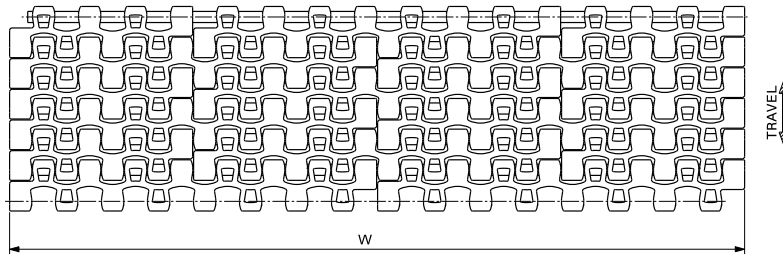
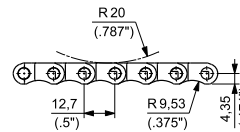
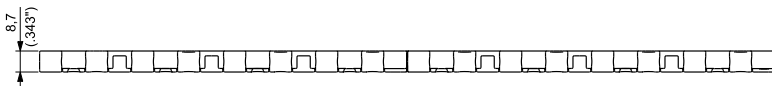

Matveyor®



Materials  
see page 12



Nosebar  
see page 182



Sprockets  
see pages 189÷193



Applications  
see page 22

WIDTH W	MATERIALS		
	Module		Pin
	<b>UP</b> ULTRA PERFORMANCE HOMOPOLYMER DELRIN®	<b>PP</b> SPECIAL POLYPROPYLENE*	
	PART NUMBER	PART NUMBER	
76,2    3	<b>200BUP003</b>	<b>200BPP003</b>	POLYPROPYLENE (PBT on request)
152,4    6	<b>200BUP006</b>	<b>200BPP006</b>	
228,6    9	<b>200BUP009</b>	<b>200BPP009</b>	
304,8    12	<b>200BUP012</b>	<b>200BPP012</b>	
381,0    15	<b>200BUP015</b>	<b>200BPP015</b>	
457,2    18	<b>200BUP018</b>	<b>200BPP018</b>	
533,4    21	<b>200BUP021</b>	<b>200BPP021</b>	
609,6    24	<b>200BUP024</b>	<b>200BPP024</b>	
685,8    27	<b>200BUP027</b>	<b>200BPP027</b>	
762,0    30	<b>200BUP030</b>	<b>200BPP030</b>	
838,2    33	<b>200BUP033</b>	<b>200BPP033</b>	
914,4    36	<b>200BUP036</b>	<b>200BPP036</b>	
990,6    39	<b>200BUP039</b>	<b>200BPP039</b>	

Belts wider than 990,6 mm (39") are available in 76,2 (3") increments.  
To identify the Part Numbers, please substitute the last three digits of the PN with the desired width.  
Example: for a 42" wide belt (=39+3 inches), the PN for UP material is "200BUP042".  
\*Actual width is larger than the nominal width.



**Standard packaging:**  
Belts are supplied in the length requested by the customer.



### 8,7 mm (0.343") THICKNESS RUBBERIZED SURFACE

Belt designed for handling packed containers like boxes, multi packs and cases in packaging lines. It is the optimal solution for high speed stop belts, metering belts, etc. The rubberized area is maximized, both in transversal and longitudinal direction, reducing gaps between the rubber pads.

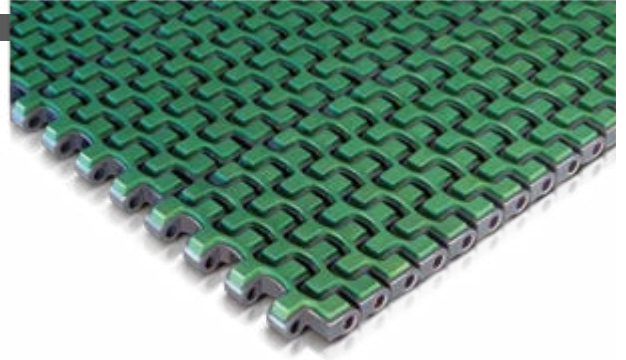

- **Belt widths:** 76,2 mm (3") or wider in 76,2 mm (3") increments
- **Working Load (at 25°C/77°F):** 14000 N/m (960 lbs/ft) for **ULF** material  
10000 N/m (685 lbs/ft) for **PP** material
- **Belt weight:** 8,86 kg/m<sup>2</sup> (1.81 lbs/ft<sup>2</sup>) for **ULF** material  
7,32 kg/m<sup>2</sup> (1.50 lbs/ft<sup>2</sup>) for **PP** material

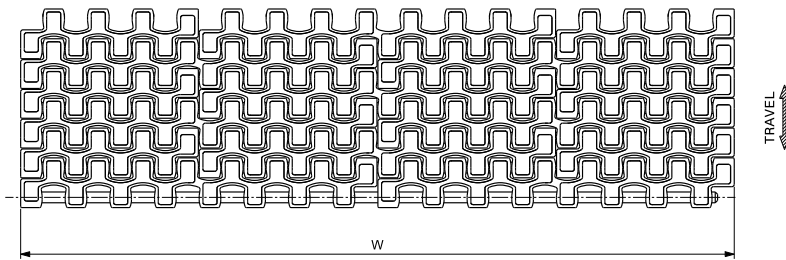
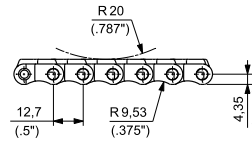
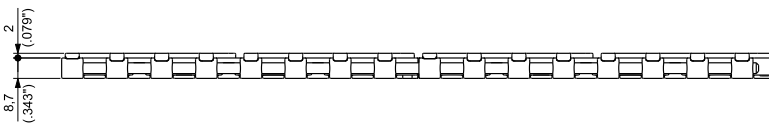

Materials see page 12



Nosebar see page 182



Sprockets see pages 189-193



Applications see page 22

WIDTH W	MATERIALS			
	Module		Rubber	Pin
	<b>ULF</b> ULTRA LOW FRICTION POLYESTER RESIN	<b>PP</b> SPECIAL POLYPROPYLENE*		
	PART NUMBER	PART NUMBER		
76,2    3	<b>HF200ULF003</b>	<b>HF200APP003</b>	THERMOPLASTIC <b>TPE</b> Hardness: 55 ShA for ULF material 50 ShA for PP material	POM for ULF material PBT for PP material
152,4    6	<b>HF200ULF006</b>	<b>HF200APP006</b>		
228,6    9	<b>HF200ULF009</b>	<b>HF200APP009</b>		
304,8    12	<b>HF200ULF012</b>	<b>HF200APP012</b>		
381,0    15	<b>HF200ULF015</b>	<b>HF200APP015</b>		
457,2    18	<b>HF200ULF018</b>	<b>HF200APP018</b>		
533,4    21	<b>HF200ULF021</b>	<b>HF200APP021</b>		
609,6    24	<b>HF200ULF024</b>	<b>HF200APP024</b>		
685,8    27	<b>HF200ULF027</b>	<b>HF200APP027</b>		
762,0    30	<b>HF200ULF030</b>	<b>HF200APP030</b>		
838,2    33	<b>HF200ULF033</b>	<b>HF200APP033</b>		
914,4    36	<b>HF200ULF036</b>	<b>HF200APP036</b>		
990,6    39	<b>HF200ULF039</b>	<b>HF200APP039</b>		

Belts wider than 990,6 mm (39") are available in 76,2 (3") increments.  
To identify the Part Numbers, please substitute the last three digits of the PN with the desired width.  
Example: for a 42" wide belt (=39+3 inches), the PN for ULF material is "HF200ULF042".  
\*Actual width is larger than the nominal width.



**Standard packaging:**  
Belts are supplied in the length requested by the customer.



## STATIC NOSEBAR FOR END-TO-END TRANSFER

The nosebar is supplied in a machined modular design having an edge curved contour with a radius that fits exactly the 1/2" pitch belts. The design, combined with UHMWPE material improved with self-lubricating additives, ensures decreased wear of belt and nosebar and constant low friction. The nosebar is fittable to the conveyor structure with M8 flat head screws (NOT INCLUDED).

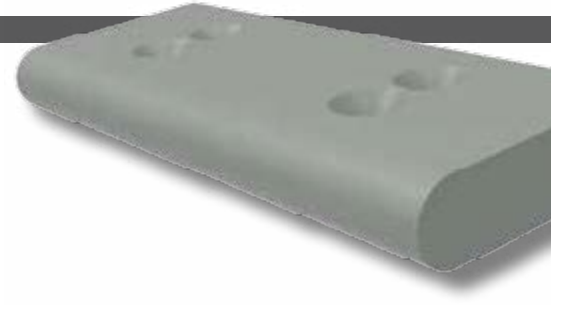

### MATERIALS

Nosebar: **SUPREME-L** Self-lubricating UHMWPE

WIDTHS W: 3", 85 mm

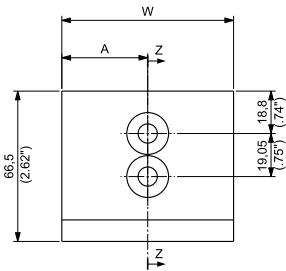

WIDTHS W: 6", 170 mm

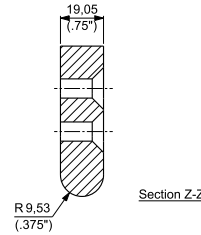
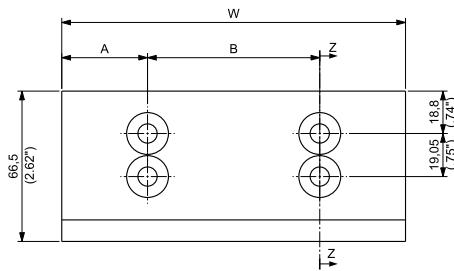

WIDTHS W: 9", 255 mm

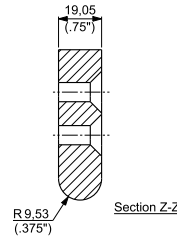
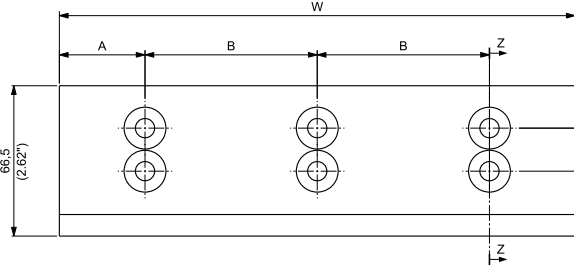

WIDTHS W: 12", 340 mm

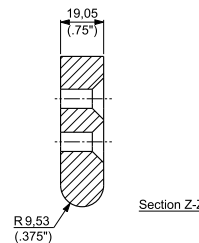
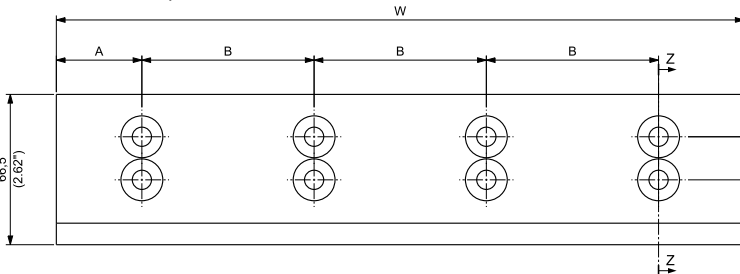

WIDTHS W: 15"

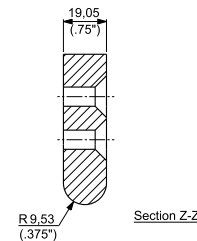
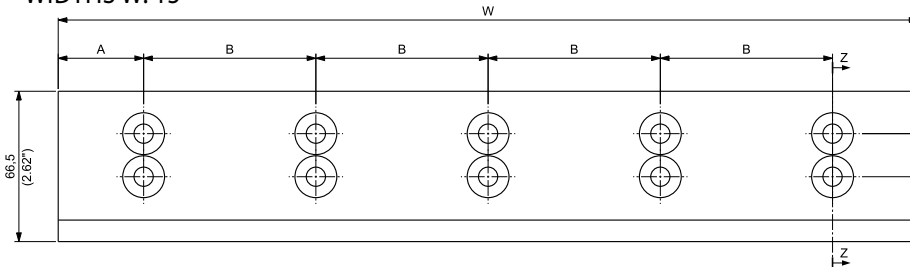

Materials see page 14

PART NUMBER	WIDTH W		A		B		WEIGHT		FOR BELTS SERIES
	mm	inch	mm	inch	mm	inch	kg	lbs	
CC000206	85,0	3.35	42,5	1.67	-	-	0,10	0.22	610 / 600
CC000207	170,0	6.69	42,5	1.67	85,0	3.35	0,19	0.42	LBP 610
CC000208	255,0	10.04	42,5	1.67	85,0	3.35	0,29	0.63	500
CC000209	340,0	13.39	42,5	1.67	85,0	3.35	0,38	0.84	HF 510
CC000201	76,2	3.00	38,1	1.50	-	-	0,09	0.19	
CC000202	152,4	6.00	38,1	1.50	76,2	3.00	0,17	0.37	300
CC000203	228,6	9.00	38,1	1.50	76,2	3.00	0,26	0.56	200
CC000204	304,8	12.00	38,1	1.50	76,2	3.00	0,34	0.75	HF 200
CC000205	381,0	15.00	38,1	1.50	76,2	3.00	0,43	0.94	

## INDUSTRIES AND APPLICATIONS

611 and RR 611 series comprise conveyor chains dedicated to the product dynamic dividing area of packaging machines. In this area, individual containers (made of plastic, metal or glass) are conveyed to the pack formation area, where the containers are clustered in the required format by dividing bars, electronically synchronized with the conveyor chains.

### INDUSTRIES

- Bottling and canning
- Food filling
- Container manufacturing
- Pharmaceutical
- Paper/cardboard
- Consumer goods

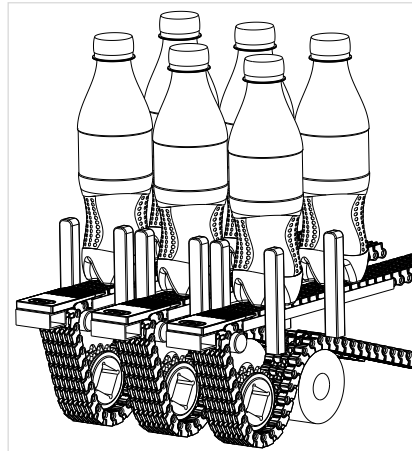

## FEATURES

- 1/2" pitch combined with curved bottom contour provides chordal effect minimization, down to 0,15 mm with a 3/4" diameter nosebar, maximizing product stability during travel and head transfer.



- Raised rib surface with special "Z" design (RR611 series) allows the best support for the most unstable products like PET bottles with petaloid bottom.



- Clipless assembly of the modules, easing chain installation on the machines with no risk of pin disassembly in application.

- The most complete range of 1/2" pitch narrow chains available on the market, with widths that range from 29 mm to 76,2 mm, that makes possible conveying all type of containers.



## 8,7 mm (0.343") THICKNESS SOLID TOP

1/2" pitch chain, combined with curved bottom contour provides chordal effect minimization, down to 0,15 mm with a 3/4" diameter nosebar, with the maximization of product stability during travel and head transfer.

**NEW**



VERSION WITHOUT TRACKING GUIDE

VERSION WITH TRACKING GUIDE

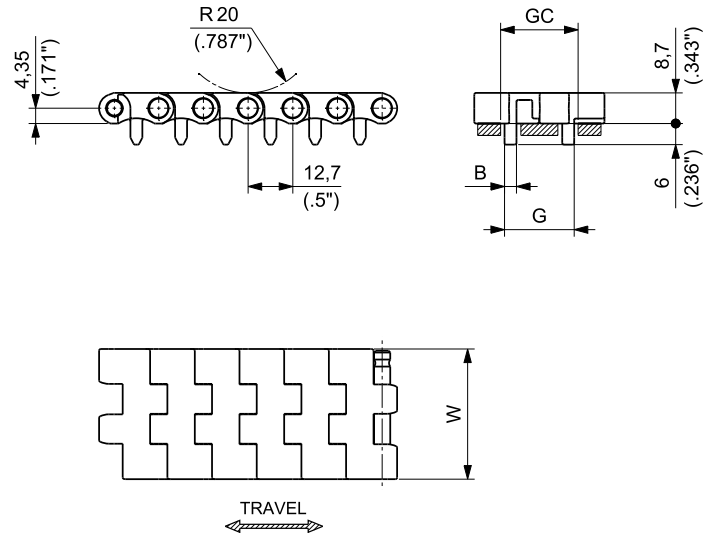
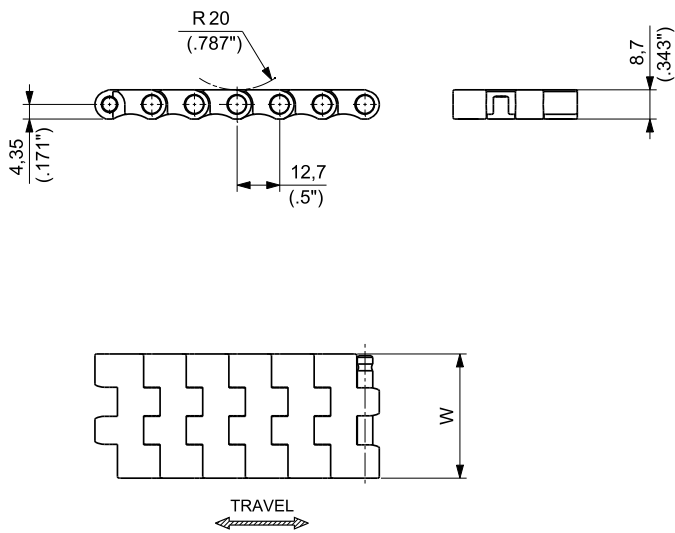

Materials  
see page 12



Sprockets  
see pages 187-193



Applications  
see page 22

MATERIALS		VERSION	ITEM DESCRIPTION	PART NUMBER	WIDTH W		GUIDE TRACK GC		INTERNAL GUIDE G		TRACKING GUIDE THICKNESS B		WORKING LOAD (25°C/77°F)		WEIGHT		
Plate	Pin				mm	inch	mm	inch	mm	inch	mm	inch	N	lbs	kg/m	lbs/ft	
ULTRA PERFORMANCE HOMOPOLYMER DELRIN® <b>UP</b>	PBT	WITHOUT TRACKING GUIDE	611A UP K 34	<b>611AUPKAA/000</b>	34	1.34	-	-	-	-	-	-	570	128	0,32	0.22	
			611A UP K 37	<b>611AUPKAD/000</b>	37	1.46	-	-	-	-	-	-	-	570	128	0,35	0.24
			611A UP K 51	<b>611AUPKB/000</b>	51	2.01	-	-	-	-	-	-	-	570	128	0,49	0.33
			611A UP K 76	<b>611AUPKDA/000</b>	76	2.99	-	-	-	-	-	-	-	1.067	240	0,75	0.50
		WITH TRACKING GUIDE	611AG UP K 29	<b>611AGUPKWB/000</b>	29	1.14	21,8	0.86	19,8	0.79	3,40	0.134	570	128	0,29	0.19	
			611AG UP K 34	<b>611AGUPKAA/000</b>	34	1.34	21,8	0.86	19,8	0.79	3,40	0.630	570	128	0,34	0.23	
			611AG UP K 37	<b>611AGUPKAD/000</b>	37	1.46	21,8	0.86	19,8	0.79	3,40	0.630	570	128	0,37	0.25	
			611AG UP K 51	<b>611AGUPKB/000</b>	51	2.01	37,8	1.49	35,8	1.41	5,00	0.926	570	128	0,52	0.35	
			611AG UP K 76	<b>611AGUPKDA/000</b>	76	2.99	45,0	1.78	43,0	1.69	5,25	0.207	1.067	240	0,77	0.52	



Standard packaging:  
Rolls of 3,048 m (10 feet)

## 8,7 mm (0.343") THICKNESS RAISED RIB

Raised rib surface with special "Z" design guarantees the best support for the most unstable products like PET bottles with petaloid base.

**NEW**



VERSION WITHOUT TRACKING GUIDE

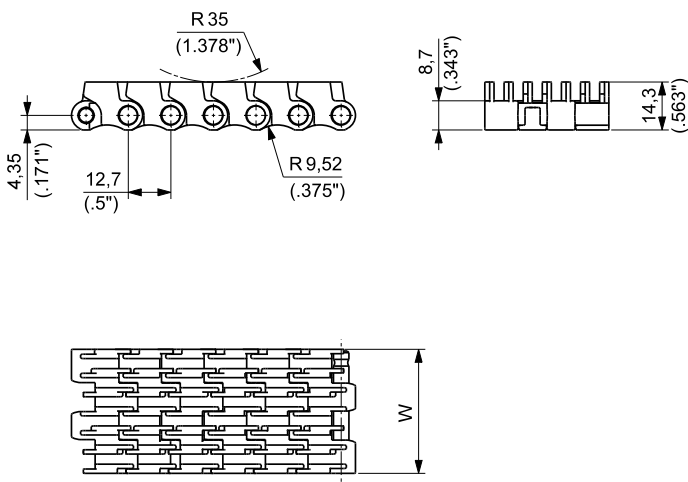

VERSION WITH TRACKING GUIDE

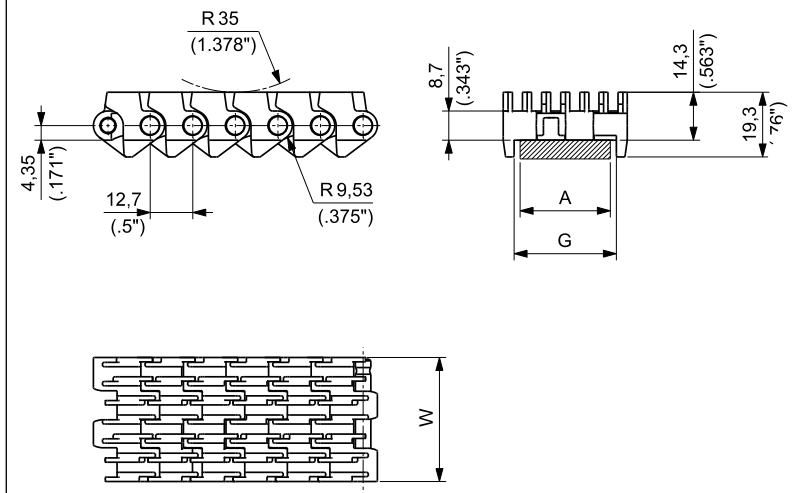

Materials  
see page 12



Combs  
see page 186



Sprockets  
see pages 189-193



Applications  
see page 22

MATERIALS		VERSION	ITEM DESCRIPTION	PART NUMBER	WIDTH W		INTERNAL GUIDE G		GUIDE TRACK A		WORKING LOAD (25°C/77°F)		WEIGHT	
Plate	Pin				mm	inch	mm	inch	mm	inch	N	lbs	kg/m	lbs/ft
ULTRA PERFORMANCE HOMOPOLYMER DELRIN® <b>UP</b>	PBT	WITHOUT TRACKING GUIDE	RR611A UP K 29	<b>RR611AUPKWB/000</b>	29	1.14	-	-	-	-	570	128	0,37	0.25
			RR611A UP K 37	<b>RR611AUPKAD/000</b>	37	1.46	-	-	-	-	570	128	0,47	0.32
			RR611A UP K 46	<b>RR611AUPKNA/000</b>	46	1.81	-	-	-	-	570	128	0,57	0.38
			RR611A UP K 55	<b>RR611AUPKCB/000</b>	55	2.17	-	-	-	-	570	128	0,69	0.46
			RR611A UP K 76	<b>RR611AUPKDA/000</b>	76	2.99	-	-	-	-	1067	240	0,75	0.50
		WITH TRACKING GUIDE	RR611AG UP K 37	<b>RR611AGUPKAD/000</b>	37	1.46	30,5	1.20	30	1.18	570	128	0,50	0.34



Standard packaging:  
Rolls of 3,048 m (10 feet)

**NEW**



## TRANSFER COMBS

Combs are supplied complete with slot covers but without fastening screws.  
One M5 hexagon socket countersunk head screw (NOT INCLUDED) is required for each comb.

### MATERIALS

COMBS: **UP** ULTRA PERFORMANCE HOMOPOLYMER DELRIN®

COMB FOR K 29 CHAIN

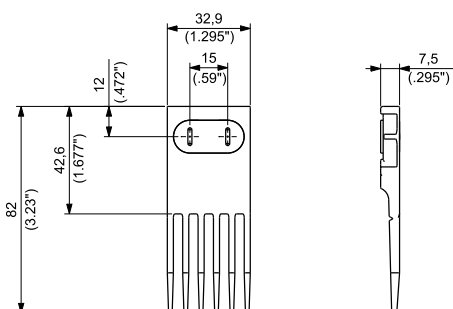

PART NUMBER **TC611-01**

COMB FOR K 37 CHAIN

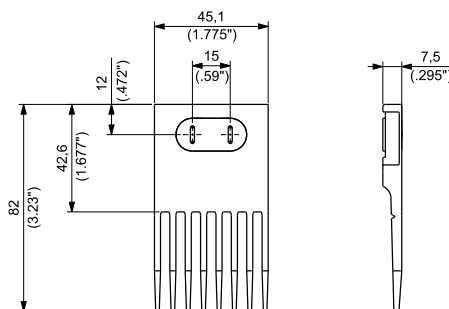

PART NUMBER **TC611-03**

COMB FOR K 46 CHAIN

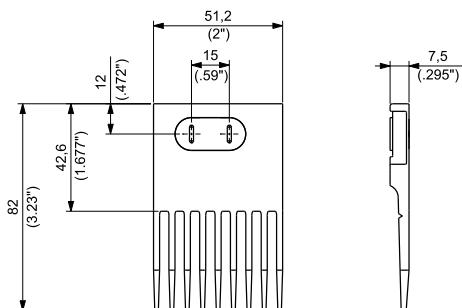

PART NUMBER **TC611-04**

COMB FOR K 55 CHAIN

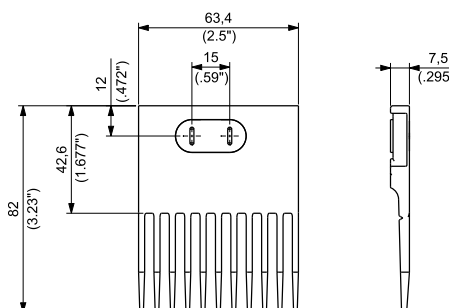

PART NUMBER **TC611-06**

COMB FOR K 76 CHAIN

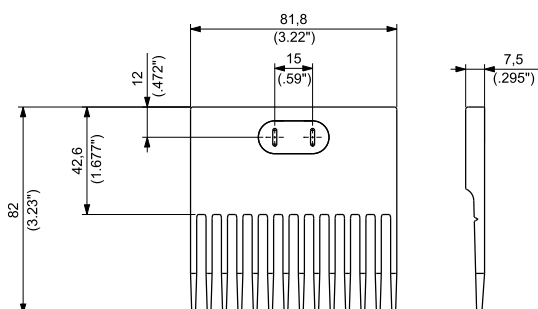

PART NUMBER **TC611-07**

## SUITABLE FOR CHAINS:

- **611 WITH TRACKING GUIDE**  
(29 mm, 34 mm, 37 mm WIDTHS ONLY)

### MATERIALS

SPROCKETS: **PGF** REINFORCED POLYAMIDE

SCREWS\*: **SS** STAINLESS STEEL

NUTS\*: **ZN** ZINC PLATED STEEL

\* For split sprockets only.



### 16T SPROCKET

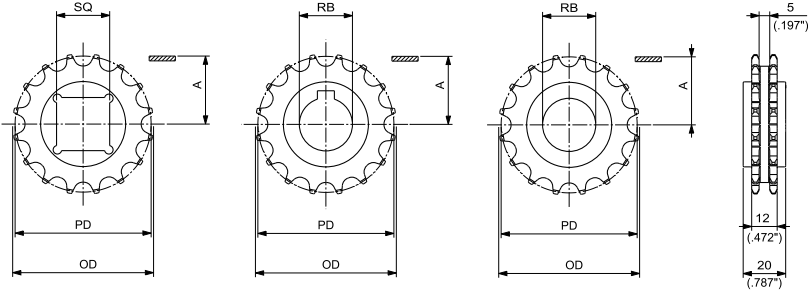

SQUARE BORE - DRIVE/IDLER

ROUND BORE - DRIVE

ROUND BORE - IDLER

### 28T SPROCKET

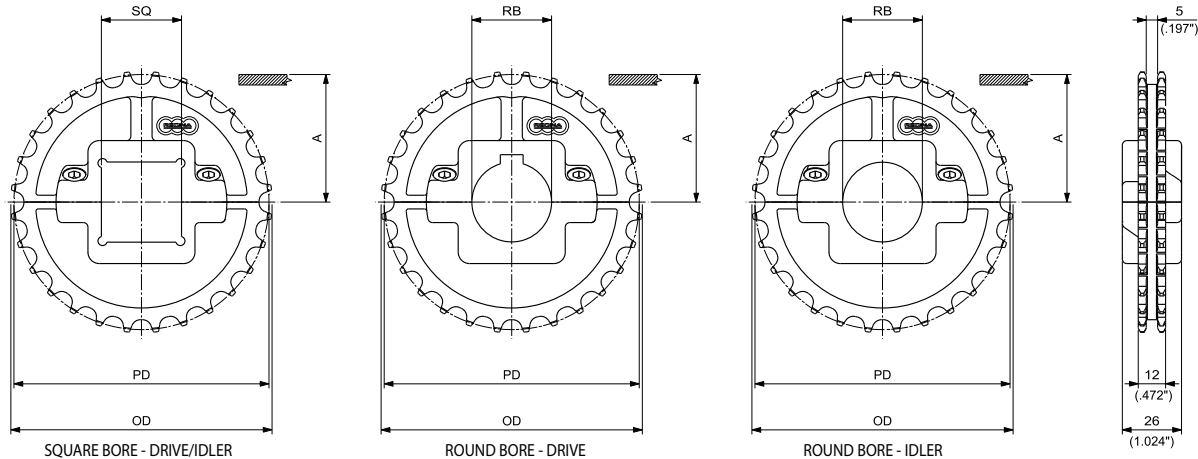

SQUARE BORE - DRIVE/IDLER

ROUND BORE - DRIVE

ROUND BORE - IDLER

### MOULDED SOLID DRIVE AND IDLER SPROCKETS

N. TEETH	PITCH DIAMETER PD		OUTSIDE DIAMETER OD		WEAR STRIP POSITIONING A		BORE SIZE*		PART NUMBER			WEIGHT	
	mm	inch	mm	inch	mm	inch	mm	inch	SQUARE BORE SQ DRIVE/IDLER	ROUND BORE RB DRIVE	ROUND BORE RB IDLER	Kg	lbs
16	65,10	2.563	66,30	2.610	28,20	1.110	20		MPBT6111620	MPBF6111620		0,05	0.11
							25	MPBQ6111625	MPBT6111625	MPBF6111625		0,04	0.09
							30		MPBT6111630	MPBF6111630		0,04	0.09
							1		MPBT61116254	MPBF61116254		0,04	0.09
							1¼		MPBT61116317	MPBF61116317		0,03	0.07

### MOULDED SPLIT DRIVE AND IDLER SPROCKETS

N. TEETH	PITCH DIAMETER PD		OUTSIDE DIAMETER OD		WEAR STRIP POSITIONING A		BORE SIZE*		PART NUMBER			WEIGHT	
	mm	inch	mm	inch	mm	inch	mm	inch**	SQUARE BORE SQ DRIVE/IDLER	ROUND BORE RB DRIVE	ROUND BORE RB IDLER	Kg	lbs
28	113,43	4.466	114,70	4.516	52,40	2.063	25		MPBST6112825	MPBSF6112825		0,15	0.33
							30		MPBST6112830	MPBSF6112830		0,15	0.33
							35		MPBST6112835	MPBSF6112835		0,14	0.31
							40	MPBSQ6112840	MPBST6112840	MPBSF6112840		0,13	0.29
							1		MPBST61128254	MPBSF61128254		0,15	0.33
							1¼		MPBST61128317	MPBSF61128317		0,14	0.31
1½	MPBSQ61128381	MPBST61128381	MPBSF61128381		0,14	0.31							

\*In case of round bore, diameter is indicated. In case of square bore, side of the square is indicated.

\*\* Imperial round bore drive sprockets are supplied with setscrew. Metric round bore drive sprockets are supplied without setscrew.



## SUITABLE FOR CHAINS:

- 611 WITH TRACKING GUIDE  
(29 mm, 34 mm, 37 mm WIDTHS ONLY)

## MATERIALS

SPROCKETS: **PA** POLYAMIDE

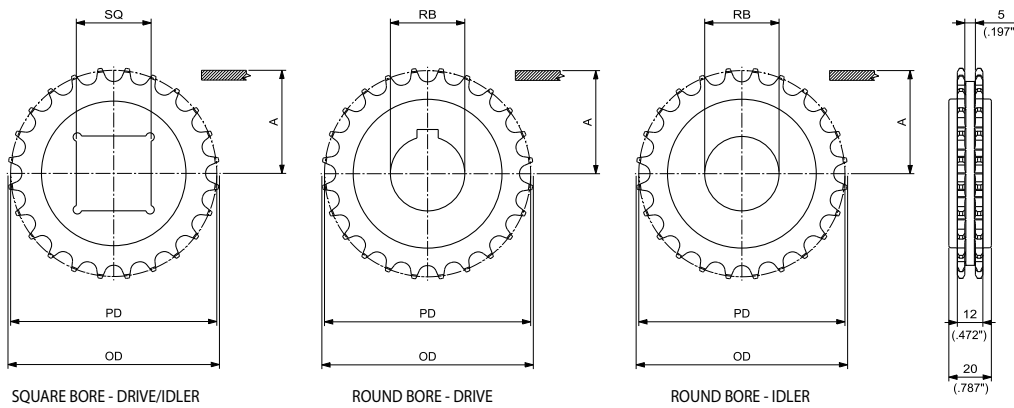

## MACHINED SOLID DRIVE AND IDLER SPROCKETS

N. TEETH	PITCH DIAMETER PD		OUTSIDE DIAMETER OD		WEAR STRIP POSITIONING A		BORE SIZE*		PART NUMBER			WEIGHT	
	mm	inch	mm	inch	mm	inch	mm	inch**	SQUARE BORE SQ DRIVE/IDLER	ROUND BORE RB DRIVE	ROUND BORE RB IDLER	Kg	lbs
24	97,30	3.831	99,50	3.917	44,30	1.744	25		<b>MPBAT6112425</b>	<b>MPBAF6112425</b>		0,10	0.22
							30		<b>MPBAT6112430</b>	<b>MPBAF6112430</b>		0,09	0.20
							35		<b>MPBAT6112435</b>	<b>MPBAF6112435</b>		0,09	0.20
							40	<b>MPBAQ6112440</b>	<b>MPBAT6112440</b>	<b>MPBAF6112440</b>		0,08	0.18
							1		<b>MPBAT61124254</b>	<b>MPBAF61124254</b>		0,10	0.22
							1¼		<b>MPBAT61124317</b>	<b>MPBAF61124317</b>		0,10	0.22
							1½	<b>MPBAQ61124381</b>	<b>MPBAT61124381</b>	<b>MPBAF61124381</b>		0,09	0.20

\*In case of round bore, diameter is indicated. In case of square bore, side of the square is indicated.

\*\* Imperial round bore drive sprockets are supplied with setscrew. Metric round bore drive sprockets are supplied without setscrew.

## SUITABLE FOR CHAINS:

- 600 / 610 / LBP 610
- 500 / HF 510
- 300
- 200 / HF 200
- 611 WITHOUT TRACKING GUIDE (ALL WIDTHS)
- 611 WITH TRACKING GUIDE (51 mm, 76 mm WIDTHS ONLY)
- RR 611 (ALL WIDTHS)

## MATERIALS

SPROCKETS: **PGF** REINFORCED POLYAMIDE



### 16T SPROCKET

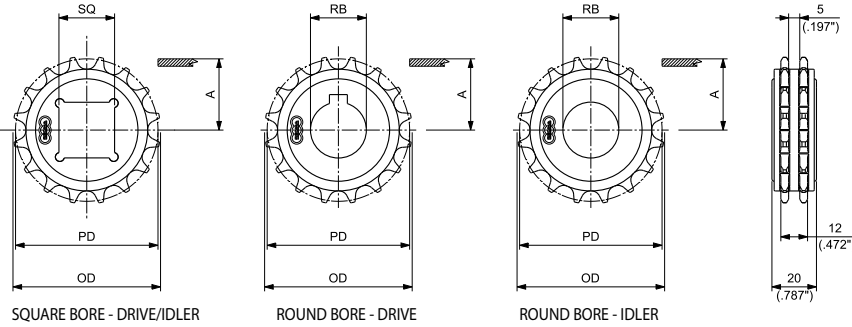

SQUARE BORE - DRIVE/IDLER

ROUND BORE - DRIVE

ROUND BORE - IDLER

### 28T SPROCKET

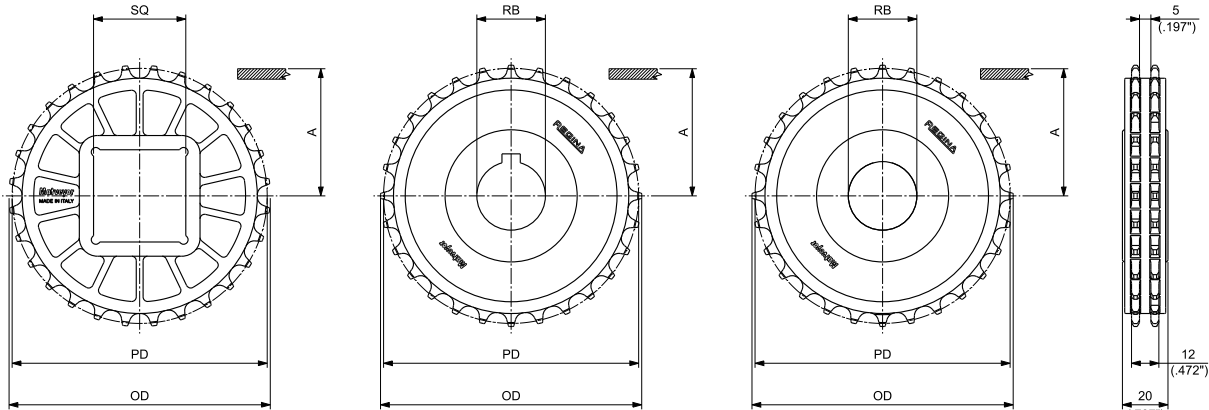

SQUARE BORE - DRIVE/IDLER

ROUND BORE - DRIVE

ROUND BORE - IDLER

## MOULDED SOLID DRIVE AND IDLER SPROCKETS

N. TEETH	PITCH DIAMETER PD		OUTSIDE DIAMETER OD		WEAR STRIP POSITIONING A		BORE SIZE*		SQUARE BORE SQ DRIVE/IDLER	PART NUMBER		WEIGHT	
	mm	inch	mm	inch	mm	inch	mm	inch		DRIVE	ROUND BORE RB IDLER	Kg	lbs
16	65,10	2.563	66,30	2.610	28,20	1.110	20			MPBT6001620	MPBF6001620	0,06	0.13
							25	MPBQ6001625	MPBF6001625	0,05	0.12		
							30	MPBT6001630	MPBF6001630	0,05	0.10		
							1	MPBT60016254	MPBF60016254	0,05	0.12		
							1¼	MPBT60016317	MPBF60016317	0,04	0.10		
							25	MPBT6002825	MPBF6002825	0,15	0.32		
28	113,43	4.466	114,70	4.516	52,40	2.063	30			MPBT6002830	MPBF6002830	0,14	0.31
							35	MPBT6002835	MPBF6002835	0,13	0.29		
							40	MPBQ6002840	MPBT6002840	MPBF6002840	0,12	0.27	
							60	MPBQ6002860			0,10	0.23	
							1	MPBT60028254	MPBF60028254	0,15	0.32		
							1¼	MPBT60028317	MPBF60028317	0,14	0.30		
							1½	MPBQ60028381	MPBT60028381	MPBF60028381	0,13	0.28	

\*In case of round bore, diameter is indicated. In case of square bore, side of the square is indicated.

## SUITABLE FOR CHAINS:

- 600 / 610 / LBP 610
- 500 / HF 510
- 300
- 200 / HF 200
- 611 WITHOUT TRACKING GUIDE (ALL WIDTHS)
- 611 WITH TRACKING GUIDE (51 mm, 76 mm WIDTHS ONLY)
- RR 611 (ALL WIDTHS)

## MATERIALS

SPROCKETS: **PA** POLYAMIDE



### 8T SPROCKET

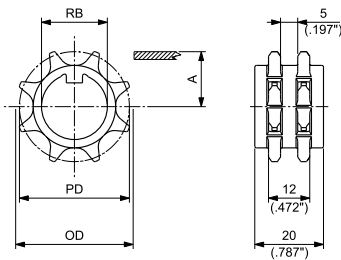

NOTE: CANNOT WORK WITH 600 AND 500 SERIES

### 14T - 19T SPROCKET

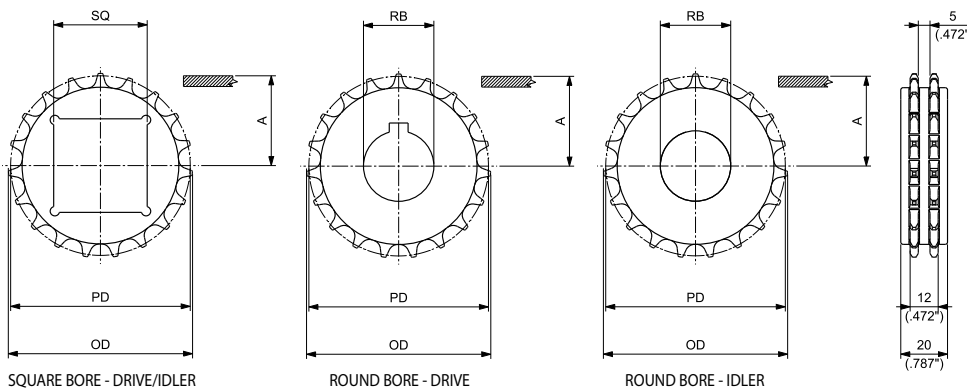

## MACHINED SOLID DRIVE AND IDLER SPROCKETS

N. TEETH	PITCH DIAMETER PD		OUTSIDE DIAMETER OD		WEAR STRIP POSITIONING A		BORE SIZE*	SQUARE BORE SQ	PART NUMBER		WEIGHT	
	mm	inch	mm	inch	mm	inch		DRIVE/IDLER	ROUND BORE RB	DRIVE	IDLER	Kg
NEW 8 <sup>(1)</sup>	33,19	1.307	34,20	1.346	12,25	0.482	20		MPBAT6000820	MPBAF6000820	0,01	0,01
									MPBAT60008190	MPBAF60008190	0,01	0,01
NEW 14	57,07	2.247	59,00	2.323	24,18	0.952	25	MPBAQ6001425	MPBAT6001425	MPBAF6001425	0,03	0,06
									MPBAT60014254	MPBAF60014254	0,03	0,06
									MPBAT6001925	MPBAF6001920	0,07	0,16
									MPBAT6001930	MPBAF6001930	0,07	0,15
									MPBAT6001935	MPBAF6001935	0,06	0,13
									MPBAQ6001940	MPBAT6001940	MPBAF6001940	0,05
19	77,15	3.037	78,80	3.102	34,20	1.346	40		MPBAT60019254	MPBAF60019254	0,07	0,16
									MPBAT60019317	MPBAF60019317	0,07	0,14
									MPBAQ60019381		0,05	0,11

\*In case of round bore, diameter is indicated. In case of square bore, side of the square is indicated.

\*\*Imperial round bore drive sprockets are supplied with setscrew (except for 8T sprocket). Metric round bore drive sprockets are supplied without setscrew.

(1) Cannot work with 600 and 500 series.

## SUITABLE FOR CHAINS:

- 600 / 610 / LBP 610
- 500 / HF 510
- 300
- 200 / HF 200
- 611 WITHOUT TRACKING GUIDE (ALL WIDTHS)
- 611 WITH TRACKING GUIDE (51 mm, 76 mm WIDTHS ONLY)
- RR 611 (ALL WIDTHS)

## MATERIALS

SPROCKETS: **PGF** REINFORCED POLYAMIDE

SCREWS: **SS** STAINLESS STEEL

NUTS: **ZN** ZINC PLATED STEEL

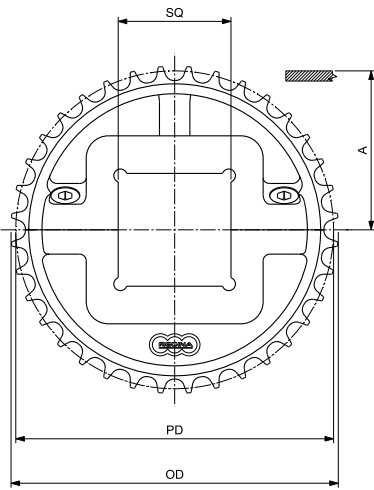

SQUARE BORE - DRIVE/IDLER

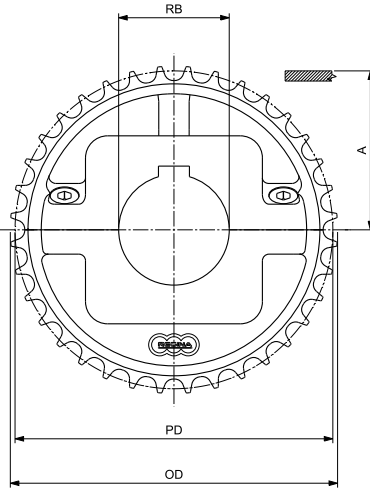

ROUND BORE - DRIVE

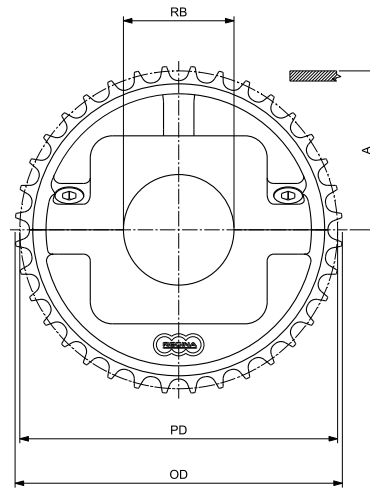

ROUND BORE - IDLER

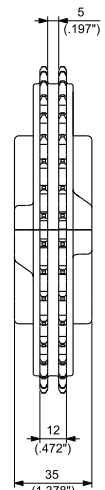

NOTE: FOR 28T SPROCKET, THE HUB WIDTH IS 26 mm (1.024")

## MOULDED SPLIT DRIVE AND IDLER SPROCKETS

N. TEETH	PITCH DIAMETER PD		OUTSIDE DIAMETER OD		WEAR STRIP POSITIONING A		BORE SIZE*		PART NUMBER			WEIGHT	
	mm	inch	mm	inch	mm	inch	mm	inch**	SQUARE BORE SQ DRIVE/IDLER	ROUND BORE RB DRIVE	ROUND BORE RB IDLER	Kg	lbs
28	113,43	4.466	114,69	4.515	52,40	2.063	25		MPBST6002825	MPBSF6002825		0,16	0,35
							30		MPBST6002830	MPBSF6002830		0,16	0,34
							35		MPBST6002835	MPBSF6002835		0,15	0,33
							40		MPBSQ6002840	MPBST6002840	MPBSF6002840	0,14	0,32
							1		MPBST60028254	MPBSF60028254		0,16	0,35
							1¼		MPBST60028317	MPBSF60028317		0,15	0,34
							1½		MPBSQ60028381	MPBST60028381	MPBSF60028381	0,15	0,32
36	145,69	5.736	148,00	5.827	68,50	2.697	30		MPBST6003630	MPBSF6003630		0,38	0,83
							35		MPBST6003635	MPBSF6003635		0,37	0,82
							40		MPBSQ6003640	MPBST6003640	MPBSF6003640	0,36	0,80
							45		MPBST6003645	MPBSF6003645		0,35	0,78
							50		MPBSQ6003650	MPBST6003650	MPBSF6003650	0,34	0,75
							1		MPBST60036254	MPBSF60036254		0,38	0,85
							1¾		MPBST60036301	MPBSF60036301		0,38	0,83
							1¼		MPBST60036317	MPBSF60036317		0,38	0,83
							1⅞		MPBST60036365	MPBSF60036365		0,37	0,81
							1½		MPBSQ60036381	MPBST60036381	MPBSF60036381	0,37	0,81
38	153,8	6.055	156,00	6.142	72,55	2.856	30		MPBST6003830	MPBSF6003830		0,39	0,86
							35		MPBST6003835	MPBSF6003835		0,38	0,84
							40		MPBSQ6003840	MPBST6003840	MPBSF6003840	0,37	0,83
							45		MPBST6003845	MPBSF6003845		0,36	0,80
							50		MPBSQ6003850	MPBST6003850	MPBSF6003850	0,35	0,78
							1		MPBST60038254	MPBSF60038254		0,40	0,87
							1¾		MPBST60038301	MPBSF60038301		0,39	0,86
							1¼		MPBST60038317	MPBSF60038317		0,39	0,86
							1⅞		MPBST60038365	MPBSF60038365		0,38	0,84
							1½		MPBSQ60038381	MPBST60038381	MPBSF60038381	0,38	0,84

\*In case of round bore, diameter is indicated. In case of square bore, side of the square is indicated.

\*\* Imperial round bore drive sprockets are supplied with setscrew. Metric round bore drive sprockets are supplied without setscrew.

## SUITABLE FOR CHAINS:

- 600 / 610 / LBP 610
- 500 / HF 510
- 300
- 200 / HF 200
- 611 WITHOUT TRACKING GUIDE (ALL WIDTHS)
- 611 WITH TRACKING GUIDE (51 mm, 76 mm WIDTHS ONLY)
- RR 611 (ALL WIDTHS)

### MATERIALS

SPROCKETS:	<b>PA</b>	POLYAMIDE
SCREWS:	<b>SS</b>	STAINLESS STEEL
NUTS:	<b>B</b>	BRASS

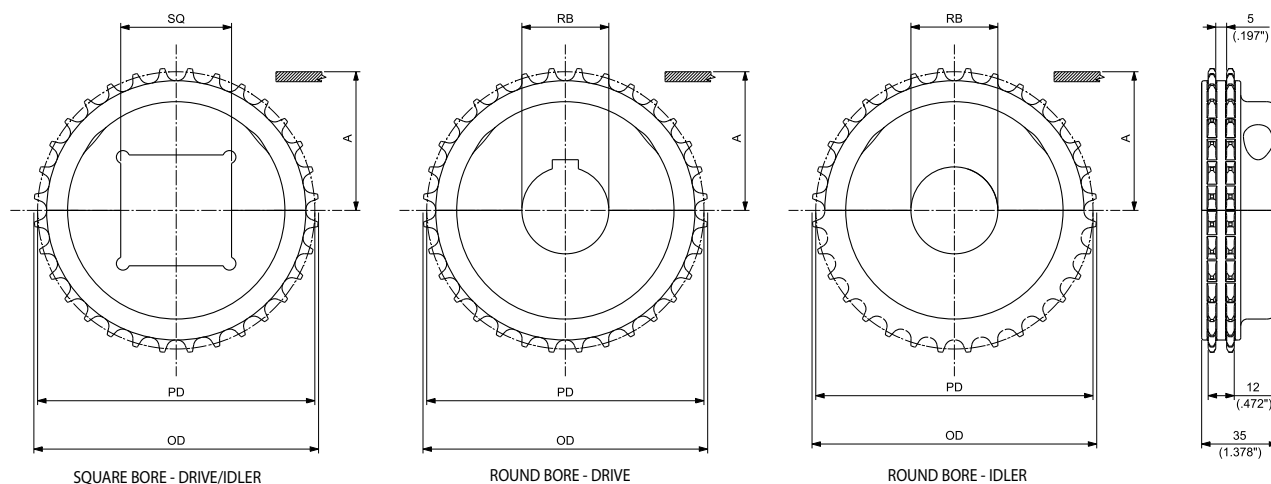

## MACHINED SPLIT DRIVE AND IDLER SPROCKETS

N. TEETH	PITCH DIAMETER PD		OUTSIDE DIAMETER OD		WEAR STRIP POSITIONING A		BORE SIZE*		PART NUMBER			WEIGHT	
	mm	inch	mm	inch	mm	inch	mm	inch**	SQUARE BORE SQ DRIVE/IDLER	ROUND BORE RB DRIVE	ROUND BORE RB IDLER	Kg	lbs
32	129,57	5.101	131,00	5.157	60,44	2.379				MPBAST6003225	MPBASF6003225	0,41	0.90
										MPBAST6003230	MPBASF6003230	0,40	0.88
										MPBAST6003235	MPBASF6003235	0,39	0.85
									MPBASQ6003240	MPBAST6003240	MPBASF6003240	0,38	0.83
										MPBAST6003245	MPBASF6003245	0,36	0.80
								MPBASQ6003250	MPBAST6003250	MPBASF6003250	0,35	0.77	
								1	MPBAST60032254	MPBASF60032254	0,41	0.90	
								1 3/16	MPBAST60032301	MPBASF60032301	0,40	0.88	
								1 1/4	MPBAST60032317	MPBASF60032317	0,39	0.87	
								1 7/16	MPBAST60032365	MPBASF60032365	0,38	0.85	
								1 1/2	MPBAST60032381	MPBASF60032381	0,38	0.84	

\*In case of round bore, diameter is indicated. In case of square bore, side of the square is indicated.

\*\* Imperial round bore drive sprockets are supplied with setscrew. Metric round bore drive sprockets are supplied without setscrew.

## SUITABLE FOR CHAINS:

- 500 / 600 / 610 / LBP 610 / HF 510  
300 / 200 / HF 200
- 1500 / 1600 / RR 1500 /  
HF 1600 / HFS 1600
- 7300 / 7200
- USPM / USP / HF USPM /  
HFS USPM / LBP USPM / LBP XSPM
- 782M / 783M / 793M

## MATERIALS

SPROCKETS: **PGF** REINFORCED POLYAMIDE

SCREWS: **SS** STAINLESS STEEL

NUTS: **ZN** ZINC PLATED STEEL

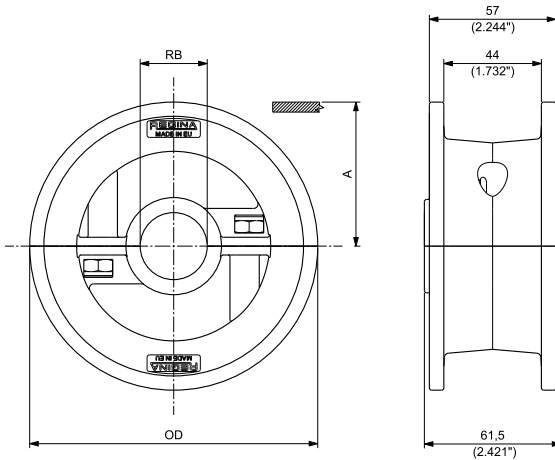

**MOULDED SOLID IDLER WHEELS**  
SEE PAGE 124



**MACHINED SPLIT IDLER WHEELS**  
SEE PAGE 126

## MOULDED SPLIT IDLER WHEELS

N. TEETH	OUTSIDE DIAMETER OD		WEAR STRIP POSITIONING A		BORE SIZE*		PART NUMBER ROUND BORE RB IDLER	WEIGHT	
	mm	inch	mm	inch	mm	inch		Kg	lbs
21	129,80	5.110	64,90	2.555	25	1	CMTS048152125	0,33	0.72
							CMTS048152130	0,33	0.73
							CMTS048152135	0,31	0.68
							CMTS048152140	0,34	0.76
							CMTS048152145	0,31	0.69
							CMTS0481521254	0,33	0.72
23	142,30	5.602	71,15	2.801	25	1 1/4	CMTS0481521317	0,33	0.71
							CMTS048152325	0,36	0.80
							CMTS048152330	0,37	0.81
							CMTS048152335	0,35	0.76
							CMTS048152340	0,38	0.84
							CMTS048152345	0,35	0.77
25	154,70	6.091	77,35	3.045	25	1	CMTS0481523254	0,36	0.80
							CMTS0481523317	0,36	0.79
							CMTS048152525	0,40	0.89
							CMTS048152530	0,41	0.90
							CMTS048152535	0,39	0.85
							CMTS048152540	0,42	0.92
25	154,70	6.091	77,35	3.045	40	1 1/4	CMTS048152545	0,39	0.86
							CMTS0481525254	0,40	0.89
							CMTS0481525317	0,40	0.88

\*Diameter is indicated.





PERFORMANCE IN MOTION

# Matveyor<sup>®</sup>

## 1" Pitch Light Duty Belts and Chains

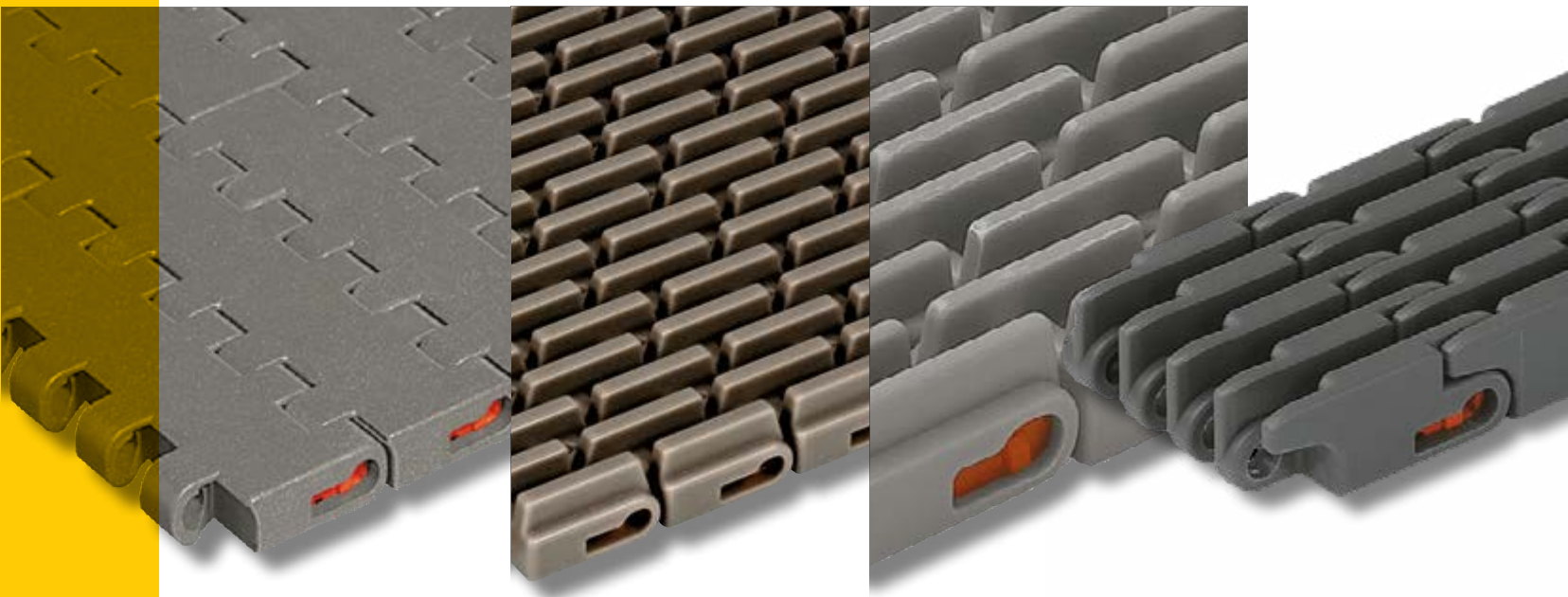

## INDUSTRIES AND APPLICATIONS

Suitable for handling both loose & packaged products, such as plastic & glass bottles and aluminium & steel cans, in light duty applications

### INDUSTRIES

Bottling and canning  
 Food filling  
 Container manufacturing  
 Pharmaceutical  
 Paper/cardboard  
 Consumer goods

### APPLICATIONS

Depalletizer  
 Pressureless Inliners and Combiners  
 Single lane & mass conveyors  
 Accumulation tables  
 Infeed packaging machines  
 Palletizers

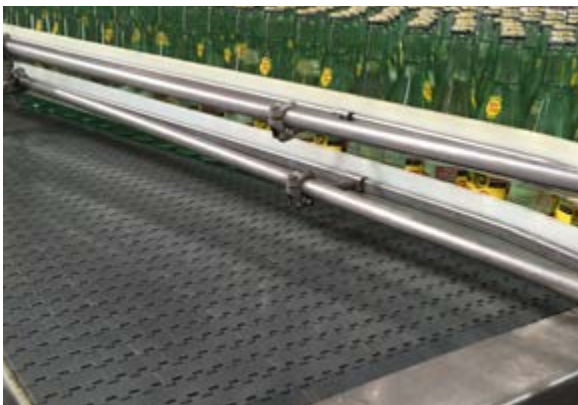

## FEATURES

- Clip integrated with the module on the belt bottom results in an easy belt assembly and disassembly and in a uniform top surface.
- Round design edge and gap minimization between hinges allow a superior product handling in linear and side transfer of the products
- Optimized bottom sliding surface to guarantee wider contact with the wear strips and higher transversal stiffness:
  - Less specific pressure between belt and wear strips
  - Less wear
  - Superior flatness
- Rubberized belts available (HF 1600 series) featuring maximum and uniform rubberized area allowing outstanding gripping capabilities on the conveyed products.
- Solid top and flush grid belts can be used on conveyors side by side with Magnetic or TAB sideflexing chains 783 or 782 series allowing a smooth products transfer between straight running and sideflexing conveyors.
- Availability of a wide range of raised rib dedicated chains RR 1600 series suitable for the product dynamic dividing area of packaging machines.

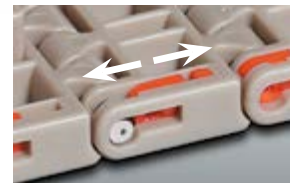

### 8,7 mm (0.343") THICKNESS SOLID TOP

Extremely good flatness, manufacturing accuracy and low coefficient of friction make the side transfer of the product very easy.  
Completely closed surface, no gap between the modules, even when engaging on the sprockets.  
Particularly suitable for glass products, small sized products and unstable conte (for example PET bottles with petaloid base).

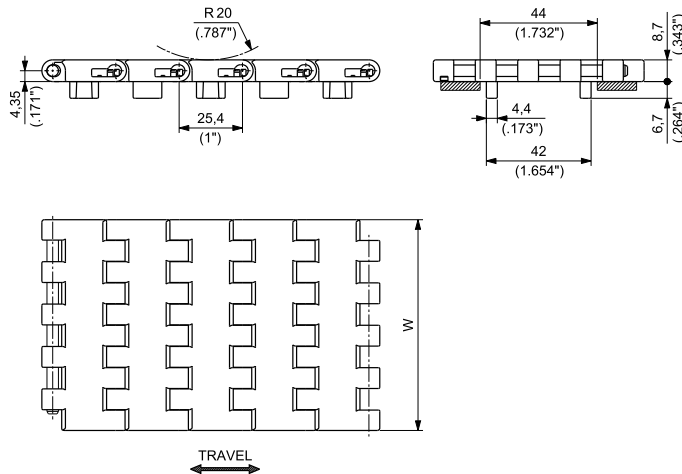

Materials  
see page 12



Sprockets  
see pages 212+218



Applications  
see page 22

MATERIALS		ITEM DESCRIPTION	PART NUMBER	WIDTH W		PLATE THICKNESS		WORKING LOAD (25°C/77°F)		WEIGHT	
Plate	Pin			mm	inch	mm	inch	N	lbs	kg/m	lbs/ft
ULTRA PERFORMANCE HOMOPOLYMER DELRIN® <b>UP</b>		1600AG UP K 83,8	1600AGUPKRA/000	83,8	3.30	8,7	0.343	1850	416	0,75	0.50
SPECIAL DELRIN® REINFORCED WITH KEVLAR® <b>DK2</b>	PBT	1600AG D2K K 83,8	1600AGD2KKRA/000	83,8	3.30	8,7	0.343	1850	416	0,75	0.50
ECOLOGICAL FRICTION ABATING THERMOPLASTIC <b>e-F.A.S.T.</b>		1600AG EF K 83,8	1600AGEFKRA/000	83,8	3.30	8,7	0.343	1850	416	0,75	0.50



Standard packaging:  
Rolls of 3,048 m (10 feet)

### 8,7 mm (0.343") THICKNESS SOLID TOP

This belt offers a smooth surface to provide excellent support and minimize product tippage. Particularly suitable for glass products, small sized products and unstable containers (for example PET bottles with petaloid base).

- **Belt widths:** 85 mm (3.346") or wider in 85 mm (3.346") increments
- **Working Load (at 25°C/77°F):** 21600 N/m (1,480 lbs/ft) for **UP**, **DK<sup>2</sup>** and **e-F.A.S.T.** materials
- **Belt weight:** 7,66 kg/m<sup>2</sup> (1.57 lbs/ft<sup>2</sup>) for **UP**, **DK<sup>2</sup>** and **e-F.A.S.T.** materials



#### VERSION WITHOUT TRACKING GUIDE

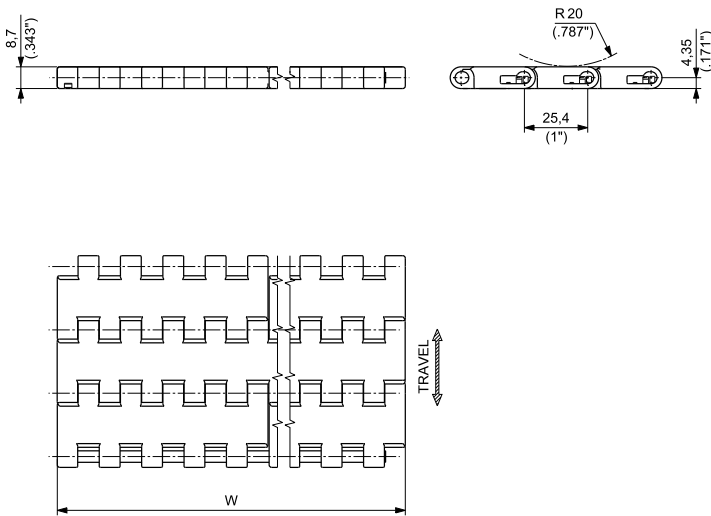

#### VERSION WITH TRACKING GUIDE

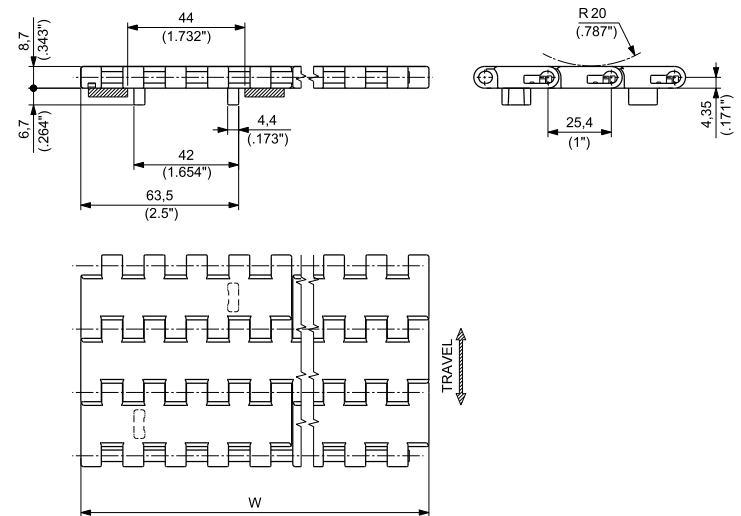

NOTE: The belt is also available with single tracking guide at both belt sides. Please contact REGINA customer service for further information.



Materials  
see page 12



Sprockets  
see pages 212÷218



Applications  
see page 22

WIDTH W		MATERIALS						Pin
		Module						
		UP ULTRA PERFORMANCE HOMOPOLYMER DELRIN®		DK <sup>2</sup> SPECIAL DELRIN® REINFORCED WITH KEVLAR®		NEW e-F.A.S.T. ECOLOGICAL FRICTION ABATING THERMOPLASTIC		
PART NUMBER		PART NUMBER		PART NUMBER		PBT		
mm	inch	WITHOUT TRACKING GUIDE	WITH TRACKING GUIDE	WITHOUT TRACKING GUIDE	WITH TRACKING GUIDE		WITHOUT TRACKING GUIDE	WITH TRACKING GUIDE
85	3.35	1600AUP0085	1600AGUP0085	1600AD2K0085	1600AGD2K0085		1600AEF0085	1600AGEF0085
170	6.69	1600BUP0170	1600BG1UP0170	1600BD2K0170	1600BG1D2K0170	1600AEF0170	1600AG1EF0170	
255	10.04	1600BUP0255	1600BG1UP0255	1600BD2K0255	1600BG1D2K0255	1600AEF0255	1600AG1EF0255	
340	13.39	1600BUP0340	1600BG1UP0340	1600BD2K0340	1600BG1D2K0340	1600AEF0340	1600AG1EF0340	
425	16.73	1600BUP0425	1600BG1UP0425	1600BD2K0425	1600BG1D2K0425	1600AEF0425	1600AG1EF0425	
510	20.08	1600BUP0510	1600BG1UP0510	1600BD2K0510	1600BG1D2K0510	1600AEF0510	1600AG1EF0510	
595	23.43	1600BUP0595	1600BG1UP0595	1600BD2K0595	1600BG1D2K0595	1600AEF0595	1600AG1EF0595	
680	26.77	1600BUP0680	1600BG1UP0680	1600BD2K0680	1600BG1D2K0680	1600AEF0680	1600AG1EF0680	
765	30.12	1600BUP0765	1600BG1UP0765	1600BD2K0765	1600BG1D2K0765	1600AEF0765	1600AG1EF0765	
850	33.46	1600BUP0850	1600BG1UP0850	1600BD2K0850	1600BG1D2K0850	1600AEF0850	1600AG1EF0850	
935	36.81	1600BUP0935	1600BG1UP0935	1600BD2K0935	1600BG1D2K0935	1600AEF0935	1600AG1EF0935	
1020	40.16	1600BUP1020	1600BG1UP1020	1600BD2K1020	1600BG1D2K1020	1600AEF1020	1600AG1EF1020	

Belts wider than 1020 mm (40.16") are available in 85 mm (3.35") increments.  
To identify the Part Numbers, please substitute the last four digits of the PN with the desired width.  
Example: for a 1105 mm wide belt (=1020+85 mm) without guide, the PN for UP material is "1600BUP1105".



Standard packaging:  
Belt widths ≤ 680 mm (26.77") are supplied in rolls of 3,048 m (10 ft) each.  
Belt widths ≥ 765 mm (30.12") are supplied in the length requested by the customer.



### 8,7 mm (0.343") THICKNESS SOLID TOP

1600G ATM can be used in combination with 1600 modular belts.  
Active transfer modules 1600G ATM allow the transfer of products between two 90° conveyor tracks without using dead plates.  
The special wing shaped module profile supports the products dynamically during transfer on the take-away belts.  
Available in left and right version.

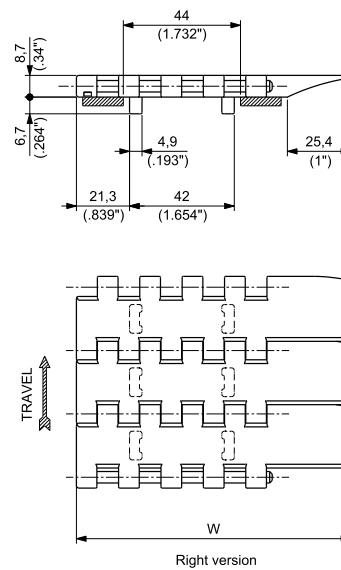
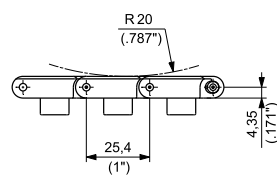
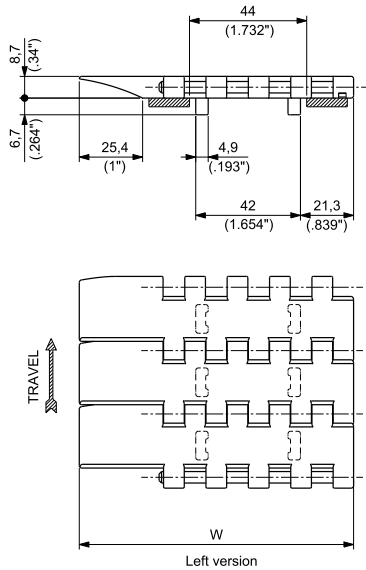

Materials see page 12



Sprockets see pages 212+218



Applications see page 22

#### 1600G ATM - Left Version

MATERIALS		ITEM DESCRIPTION	PART NUMBER	WIDTH W		PLATE THICKNESS		WORKING LOAD (25°C/77°F)		WEIGHT	
Plate	Pin			mm	inch	mm	inch	N	lbs	kg/m	lbs/ft
ULTRA PERFORMANCE HOMOPOLYMER DELRIN® <b>UP</b>		1600BGATM UP 0085 SX	1600BGATMUP085S	110	4.33	8,7	0.343	1840	414	0,85	0.57
SPECIAL DELRIN® REINFORCED WITH KEVLAR® POLYPROPYLENE <b>DK2</b>		1600AGTM D2K 0085 SX	1600AGTMD2K085S	110	4.33	8,7	0.343	1840	414	0,85	0.57
ECOLOGICAL FRICTION ABATING THERMOPLASTIC <b>e-FAST</b>		1600AGTM EF 0085 SX	1600AGATMEF085S	110	4.33	8,7	0.343	1840	414	0,85	0.57

#### 1600G ATM - Right Version

MATERIALS		ITEM DESCRIPTION	PART NUMBER	WIDTH W		PLATE THICKNESS		WORKING LOAD (25°C/77°F)		WEIGHT	
Plate	Pin			mm	inch	mm	inch	N	lbs	kg/m	lbs/ft
ULTRA PERFORMANCE HOMOPOLYMER DELRIN® <b>UP</b>		1600BGATM UP 0085 DX	1600BGATMUP085D	110	4.33	8,7	0.343	1840	414	0,85	0.57
		1600BGATM UP 0170 DX	1600BGATMUP170D	195	7.68	8,7	0.343	3670	825	1,51	1.01
SPECIAL DELRIN® REINFORCED WITH KEVLAR® POLYPROPYLENE <b>DK2</b>		1600BGATM D2K 0085 DX	1600BGATMD2K085D	110	4.33	8,7	0.343	1840	414	0,85	0.57
		1600BGATM D2K 0170 DX	1600BGATMD2K170D	195	7.68	8,7	0.343	3670	825	1,51	1.01
ECOLOGICAL FRICTION ABATING THERMOPLASTIC <b>e-FAST</b>		1600AGTM EF 0085 DX	1600AGATMEF085D	110	4.33	8,7	0.343	1840	414	0,85	0.57
		1600AGTM EF 0170 DX	1600AGATMEF170D	195	7.68	8,7	0.343	3670	825	1,51	1.01



Standard packaging:  
Rolls of 3,048 m (10 feet)

## 8,7 mm (0.343") THICKNESS FLUSH GRID

This belt has an excellent combination of open and support areas to allow drainage of liquids and good support of the conveyed product. This belt is particularly suitable for conveying of aluminium cans.

- **Belt widths:** 85 mm (3.346") or wider in 85 mm (3.346") increments
- **Working Load (at 25°C/77°F):** 21600 N/m (1,480 lbs/ft) for **UP** and **DK2™** materials  
13200 N/m (904 lbs/ft) for **PP** material
- **Belt weight:** 6,58 kg/m<sup>2</sup> (1.58 lbs/ft<sup>2</sup>) for **UP** and **DK2™** materials  
4,43 kg/m<sup>2</sup> (1.35 lbs/ft<sup>2</sup>) for **PP** material



### VERSION WITHOUT TRACKING GUIDE

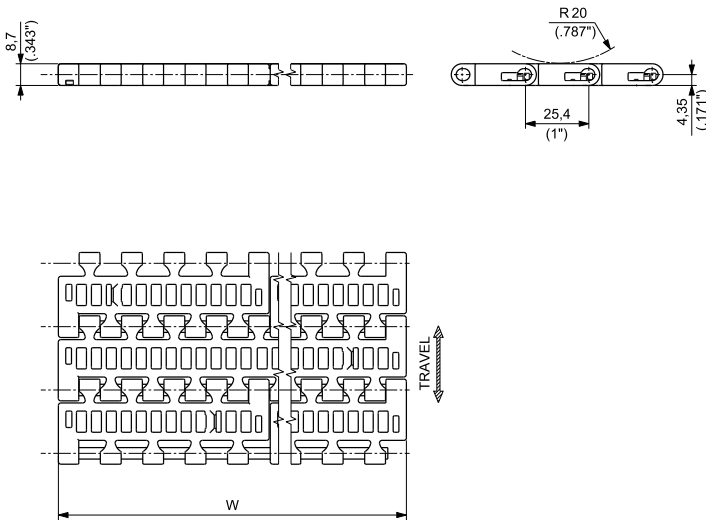

### VERSION WITH TRACKING GUIDE

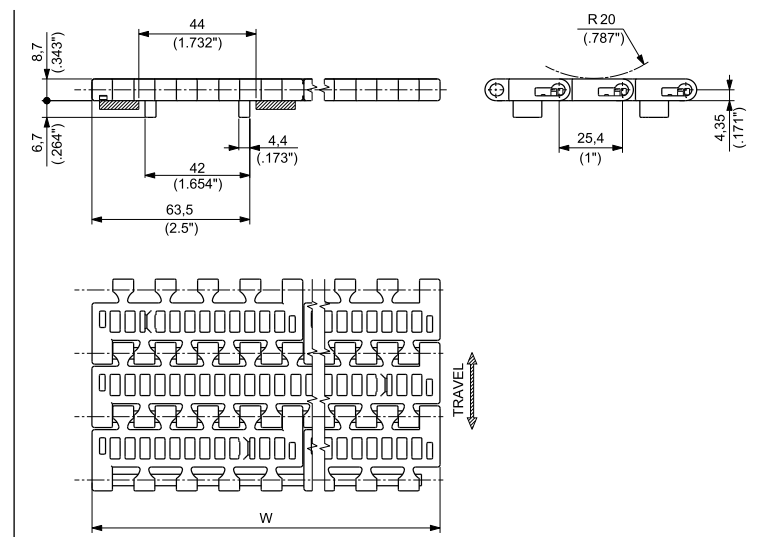

NOTE: The belt is also available with single tracking guide at both belt sides. Please contact REGINA customer service for further information.



Materials see page 12



Sprockets see pages 212÷218



Applications see page 22

WIDTH W		MATERIALS						Pin
		UP		DK2™		PP		
		ULTRA PERFORMANCE HOMOPOLYMER DELRIN®		SPECIAL DELRIN® REINFORCED WITH KEVLAR®		SPECIAL POLYPROPYLENE*		
PART NUMBER		PART NUMBER		PART NUMBER				
mm	inch	WITHOUT TRACKING GUIDE	WITH TRACKING GUIDE	WITHOUT TRACKING GUIDE	WITH TRACKING GUIDE	WITHOUT TRACKING GUIDE	WITH TRACKING GUIDE	
85	3.35	1500AUP0085	1500AGUP0085	1500AD2K0085	1500AGD2K0085	1500APP0085	1500AGPP0085	PBT
170	6.69	1500BUP0170	1500BG1UP0170	1500BD2K0170	1500BG1D2K0170	1500BPP0170	1500BG1PP0170	POLYPROPYLENE (PBT on request)
255	10.04	1500BUP0255	1500BG1UP0255	1500BD2K0255	1500BG1D2K0255	1500BPP0255	1500BG1PP0255	
340	13.39	1500BUP0340	1500BG1UP0340	1500BD2K0340	1500BG1D2K0340	1500BPP0340	1500BG1PP0340	
425	16.73	1500BUP0425	1500BG1UP0425	1500BD2K0425	1500BG1D2K0425	1500BPP0425	1500BG1PP0425	
510	20.08	1500BUP0510	1500BG1UP0510	1500BD2K0510	1500BG1D2K0510	1500BPP0510	1500BG1PP0510	
595	23.43	1500BUP0595	1500BG1UP0595	1500BD2K0595	1500BG1D2K0595	1500BPP0595	1500BG1PP0595	
680	26.77	1500BUP0680	1500BG1UP0680	1500BD2K0680	1500BG1D2K0680	1500BPP0680	1500BG1PP0680	
765	30.12	1500BUP0765	1500BG1UP0765	1500BD2K0765	1500BG1D2K0765	1500BPP0765	1500BG1PP0765	
850	33.46	1500BUP0850	1500BG1UP0850	1500BD2K0850	1500BG1D2K0850	1500BPP0850	1500BG1PP0850	
935	36.81	1500BUP0935	1500BG1UP0935	1500BD2K0935	1500BG1D2K0935	1500BPP0935	1500BG1PP0935	
1020	40.16	1500BUP1020	1500BG1UP1020	1500BD2K1020	1500BG1D2K1020	1500BPP1020	1500BG1PP1020	

Belts wider than 1020 mm (40.16") are available in 85 mm (3.35") increments.  
To identify the Part Numbers, please substitute the last four digits of the PN with the desired width.  
Example: for a 1105 mm wide belt (=1020+85 mm) without guide, the PN for UP material is "1500BUP1105".  
\* Actual width is larger than the nominal width.



Standard packaging:  
Belt widths ≤ 680 mm (26.77") are supplied in rolls of 3,048 m (10 ft) each.  
Belt widths ≥ 765 mm (30.12") are supplied in the length requested by the customer.



### 8,7 mm (0.343") THICKNESS FLUSH GRID

This belt has an excellent combination of open and support areas to allow drainage of liquids and good support of the conveyed product. This belt is particularly suitable for conveying of aluminium cans.

- **Belt widths:** 85 mm (3.346") or wider in 85 mm (3.346") increments
- **Working Load (at 25°C/77°F):** 21600 N/m (1,480 lbs/ft) for **e-FAST** materials
- **Belt weight:** 6,58 kg/m<sup>2</sup> (1.58 lbs/ft<sup>2</sup>) for **e-FAST** materials



VERSION WITHOUT TRACKING GUIDE

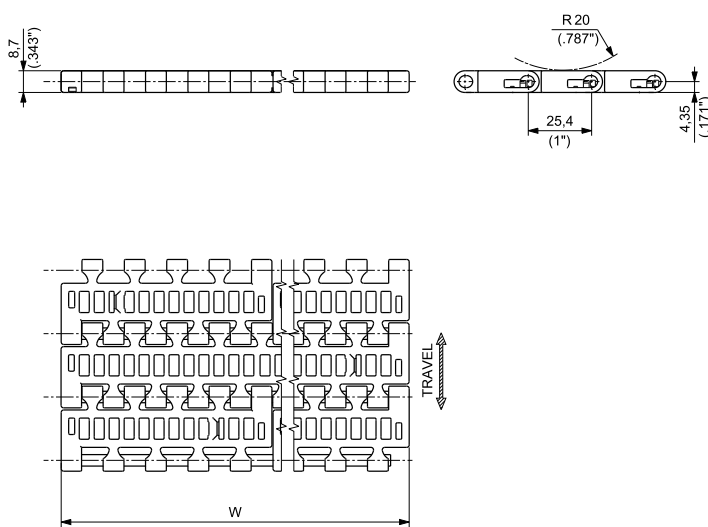

VERSION WITH TRACKING GUIDE

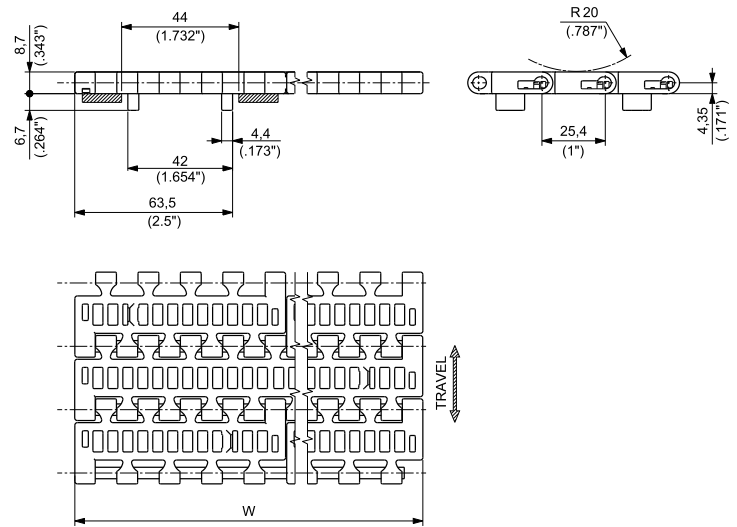

NOTE: The belt is also available with single tracking guide at both belt sides. Please contact REGINA customer service for further information.



Materials  
see page 12



Sprockets  
see pages 212÷218



Applications  
see page 22

WIDTH W		MATERIALS		
		Module	Pin	
		<b>NEW</b> <b>e-FAST</b> ECOLOGICAL FRICTION ABATING THERMOPLASTIC	PBT	
		PART NUMBER		
mm	inch	WITHOUT TRACKING GUIDE		WITH TRACKING GUIDE
85	3.35	<b>1500AEF0085</b>		<b>1500AG1EF0085</b>
170	6.69	<b>1500AEF0170</b>	<b>1500AG1EF0170</b>	
255	10.04	<b>1500AEF0255</b>	<b>1500AG1EF0255</b>	
340	13.39	<b>1500AEF0340</b>	<b>1500AG1EF0340</b>	
425	16.73	<b>1500AEF0425</b>	<b>1500AG1EF0425</b>	
510	20.08	<b>1500AEF0510</b>	<b>1500AG1EF0510</b>	
595	23.43	<b>1500AEF0595</b>	<b>1500AG1EF0595</b>	
680	26.77	<b>1500AEF0680</b>	<b>1500AG1EF0680</b>	
765	30.12	<b>1500AEF0765</b>	<b>1500AG1EF0765</b>	
850	33.46	<b>1500AEF0850</b>	<b>1500AG1EF0850</b>	
935	36.81	<b>1500AEF0935</b>	<b>1500AG1EF0935</b>	
1020	40.16	<b>1500AEF1020</b>	<b>1500AG1EF1020</b>	

Belts wider than 1020 mm (40.16") are available in 85 mm (3.35") increments.  
To identify the Part Numbers, please substitute the last four digits of the PN with the desired width.  
Example: for a 1105 mm wide belt (=1020+85 mm) without guide, the PN for EF material is "1500AEF1105".  
\* Actual width is larger than the nominal width.



**Standard packaging:**  
Belt widths ≤ 680 mm (26.77") are supplied in rolls of 3,048 m (10 ft) each.  
Belt widths ≥ 765 mm (30.12") are supplied in the length requested by the customer.

### ACTIVE TRANSFER MODULES 8,7 mm (0.343") THICKNESS FLUSH GRID

1500G ATM can be used in combination with 1500 Modular belts series.  
Active transfer modules 1500G ATM allow the transfer of products between two 90° conveyor tracks without using dead plates.  
The special wing shaped module profile supports the products dynamically during transfer on the take-away belt.  
This system is particularly suitable for aluminium cans.

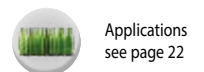
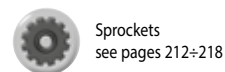
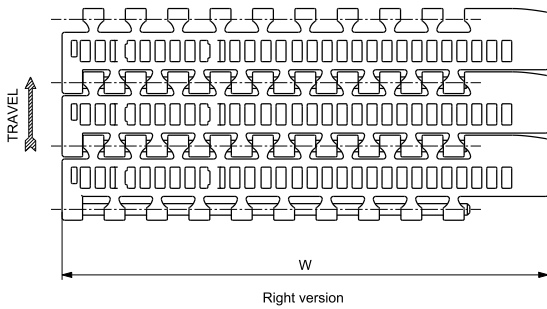
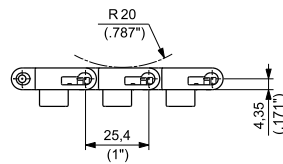
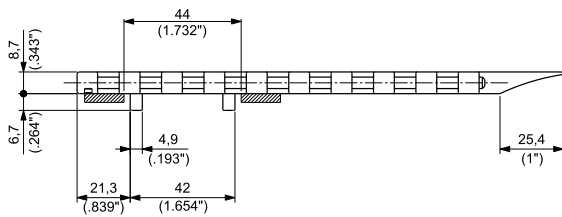

### 1500G ATM - Right Version

MATERIALS		ITEM DESCRIPTION	PART NUMBER	WIDTH W		PLATE THICKNESS		WORKING LOAD (25°C/77°F)		WEIGHT	
Plate	Pin			mm	inch	mm	inch	N	lbs	kg/m	lbs/ft
ULTRA PERFORMANCE HOMOPOLYMER DELRIN® <b>UP</b>		1500BGATM UP 0170 DX	1500BGATMUP170D	195	7.68	8,7	0.343	3670	825	0,85	0.57
SPECIAL DELRIN® REINFORCED WITH KEVLAR® POLYPROPYLENE <b>DK2</b>		1500BGATM D2K 0170 DX	1500BGATMD2K170D	195	7.68	8,7	0.343	3670	825	0,85	0.57
ECOLOGICAL FRICTION ABATING THERMOPLASTIC <b>e-FAST</b>	<b>NEW</b>	1500AGATM EF 0170 DX	1500AGATMEF170D	195	7.68	8,7	0.343	3670	825	0,85	0.57

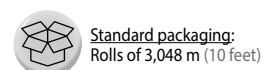

## 1600 AND 1500 SERIES FOR INCLINE/DECLINE APPLICATIONS

**NEW**

The 1600 and 1500 series are also available in a version with flights.  
 Flights can now be integrated into 1600 or 1500 series conveyors, to convey products in incline or decline applications.  
 Flight modules are single-piece elements made by injection-molding that, once assembled, become an integral part of the belt.

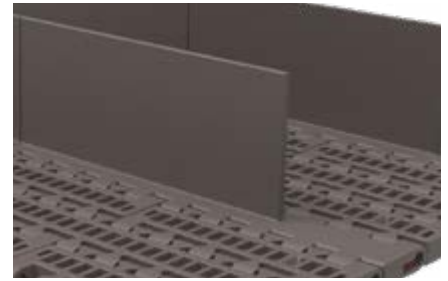
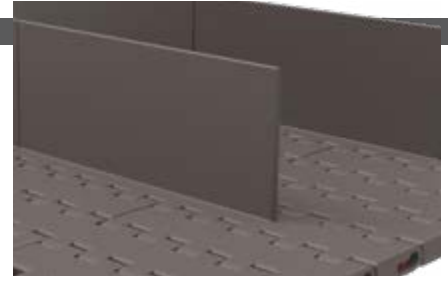

Flights are available in 1" (25,4 mm), 2" (50,8 mm) or 3" (76,2 mm) standard heights (F dimension).  
 Flights can be as wide as the module (see exhibit 1), or have a 45 mm (1.772") side indent (see exhibit 2).

EXHIBIT 1

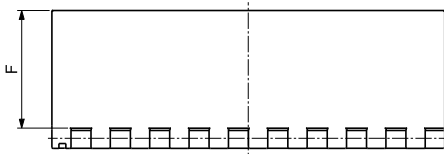
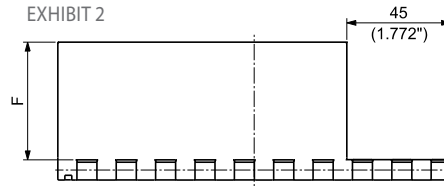

EXHIBIT 2



The position of flights into a 1600 or 1500 modular belt can be customized to fit different applications or conveyor designs, by specifying the following parameters:

- 1) Flights pitch (K): distance between 2 rows of flights (see exhibit 3).

EXHIBIT 3

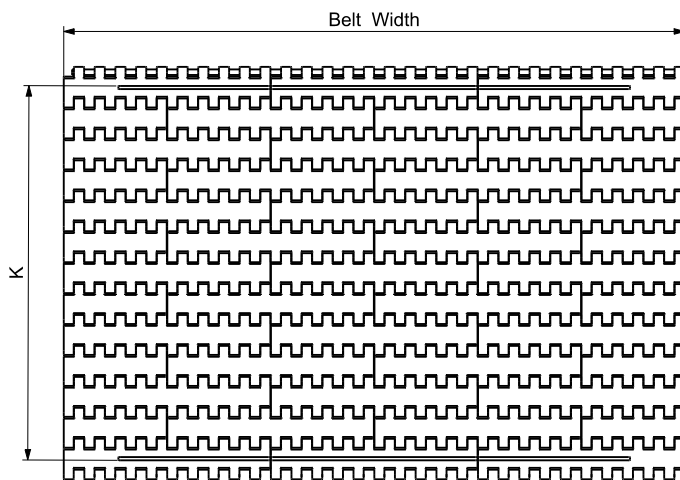

2) Indent (see configuration examples below): the flight indent (N) is the distance between the edge of the belt and the edge of the flight.

It is required to support the belt on its return ways and to hold it down during back flexing.

Standard indent (N) values:

- No side indent
- 45 mm (1.772")

3) N. of Notches and dimension (see configuration examples below): the notch (G) is a gap in each row of flights, longitudinally aligned, to allow supporting the belts on their return ways or in backflexing applications.

The distance (D) is the notch distance from the belt edge.

4) N. of Notches available:

- N. 1 notch in the centre
- N. 2 symmetrical notches
- N. 3 symmetrical notches

The belt can be also supplied without notches.

Standard gap (G) values:

- 45 mm (1.772")

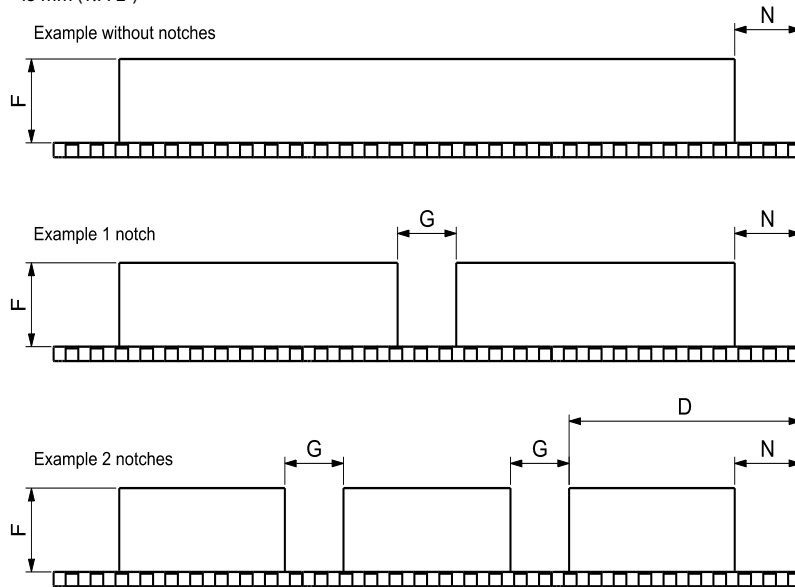

## CATALOGUE REFERENCE

Use the checklist below to select the correct belt version according to the application needs. Check boxes and fill-in the required values, then contact REGINA Sales Department.

**SERIES:** 1500 (Flush grid surfaces)

**MATERIAL:** Polypropylene PP (grey)

Belt Width (W)	<input type="text"/>	(multiples of 85 mm increments)
Flight height (F)	<input type="checkbox"/>	1" (25,4 mm)
	<input type="checkbox"/>	2" (50,8 mm)
	<input type="checkbox"/>	3" (76,2 mm)
	<input type="text"/>	(special value less than 3" on request)
Flights pitch (K)	<input type="text"/>	(flights row every.. <sup>th</sup> belt row)
Side indent (N)	<input type="checkbox"/>	No side indent
	<input type="checkbox"/>	45 mm (1.771") indent
	<input type="text"/>	(special value on request)
N. of notches	<input type="checkbox"/>	No notch
	<input type="checkbox"/>	1 notch in the centre
	<input type="checkbox"/>	2 symmetrical notches
	<input type="checkbox"/>	3 symmetrical notches
Notch width (G)	<input type="checkbox"/>	45 mm (1.771")
	<input type="text"/>	(special value on request)
Notch distance (D)	<input type="text"/>	

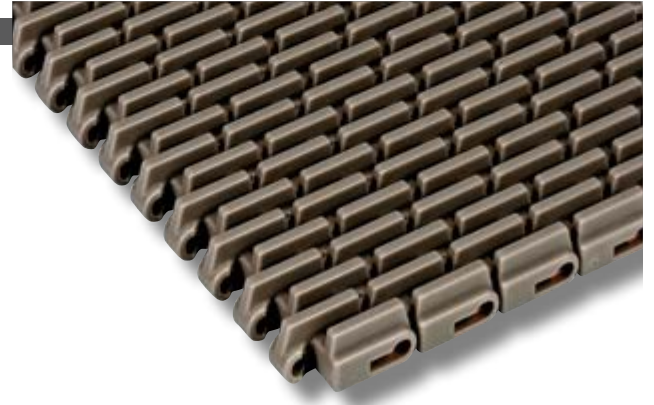

### 8,7 mm (0.343") THICKNESS RAISED RIB

This belt allows smooth head transfer of the products, thanks to the optimized ratio rib thickness / spacing and the special click-combs.  
Particularly suitable for products infeed of packaging machines.

- **Belt widths:** 170 mm (6.69") or wider in 85 mm (3.34") increments
- **Working Load (at 25°C/77°F):** 21600 N/m (1,480 lbs/ft)
- **Belt weight:** 9,62 kg/m<sup>2</sup> (1.97 lbs/ft<sup>2</sup>)

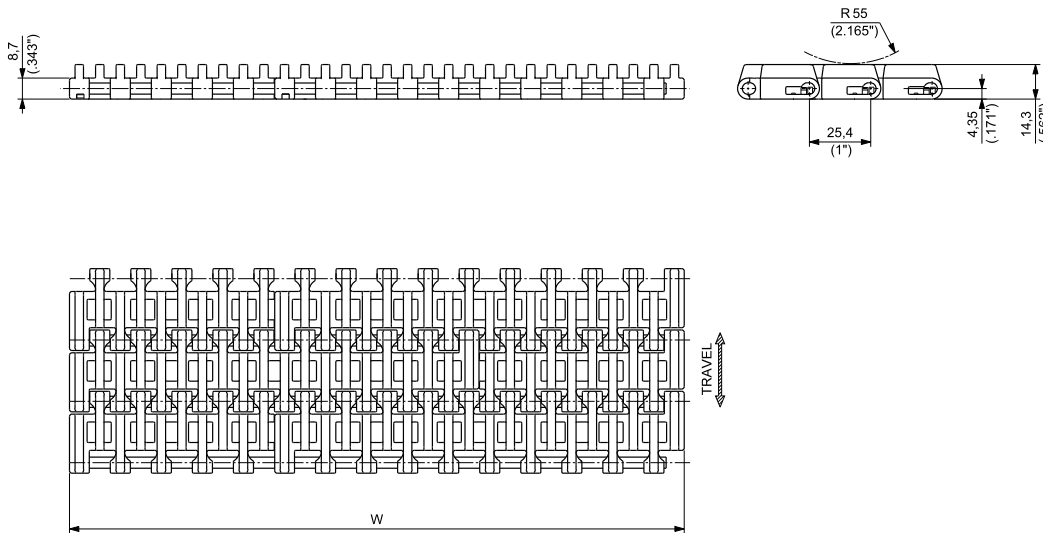

Materials  
see page 12



Combs  
see page 205



Sprockets  
see pages 212-218



Applications  
see page 22

WIDTH W		MATERIALS	
		Module	Pin
		<b>UP</b> ULTRA PERFORMANCE HOMOPOLYMER DELRIN®	POLYPROPYLENE
		PART NUMBER	
mm	inch		
170	6.69	<b>RR1500BUP0170</b>	
255	10.04	<b>RR1500BUP0255</b>	
340	13.39	<b>RR1500BUP0340</b>	
425	16.73	<b>RR1500BUP0425</b>	
510	20.08	<b>RR1500BUP0510</b>	
595	23.43	<b>RR1500BUP0595</b>	
680	26.77	<b>RR1500BUP0680</b>	
765	30.12	<b>RR1500BUP0765</b>	
850	33.46	<b>RR1500BUP0850</b>	
935	36.81	<b>RR1500BUP0935</b>	
1020	40.16	<b>RR1500BUP1020</b>	

Belts wider than 1020 mm (40.16") are available in 85 mm (3.35") increments.  
To identify the Part Numbers, please substitute the last four digits of the PN with the desired width.  
Example: for a 1105 mm wide belt (=1020+85 mm), the PN for UP material is "RR1500BUP1105".



**Standard packaging:**  
Belt widths ≤ 680 mm (26.77") are supplied in rolls of 3,048 m (10 ft) each.  
Belt widths ≥ 765 mm (30.12") are supplied in the length requested by the customer.

## TRANSFER COMBS

The comb is click-fitted on the omega style profile without using any fastening screws.



### MATERIALS

COMBS: **DG** ACETAL RESIN

PROFILE: **SS** STAINLESS STEEL

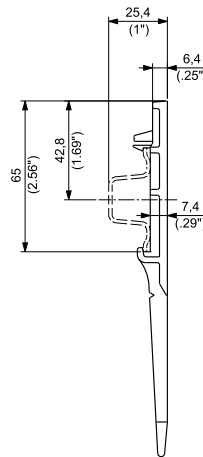
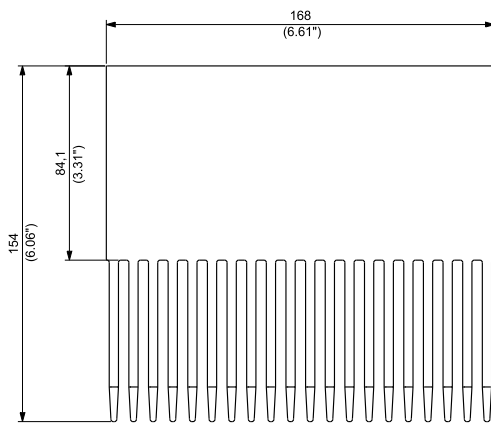

PART NUMBER **TC1500-01**

### OMEGA STYLE PROFILE

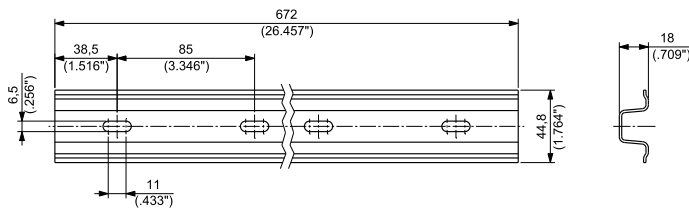

PART NUMBER **PRT-RR1500-0672**





### 8,7 mm (0.343") THICKNESS RUBBERIZED SURFACE - FULL COVER

This belt is specifically designed for handling shrink wrapped packs, boxes, plastic trays and other type of containers in incline, decline or timing applications.  
The rubberized area is maximized to provide outstanding gripping capabilities on the conveyed products.

- **Belt widths:** 85 mm (3.346") or wider in 85 mm (3.346") increments
- **Working Load (at 25°C/77°F):** 21600 N/m (1,480 lbs/ft) for **ULF** material  
13200 N/m (904 lbs/ft) for **PP** material
- **Belt weight:** 9,05 kg/m<sup>2</sup> (1.85 lbs/ft<sup>2</sup>) for **ULF** material  
6,84 kg/m<sup>2</sup> (1.40 lbs/ft<sup>2</sup>) for **PP** material

#### VERSION WITHOUT TRACKING GUIDE

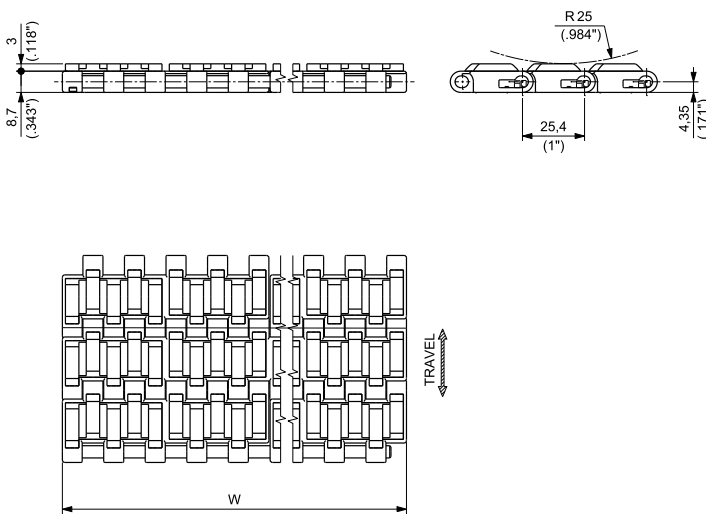

#### VERSION WITH TRACKING GUIDE

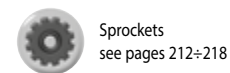
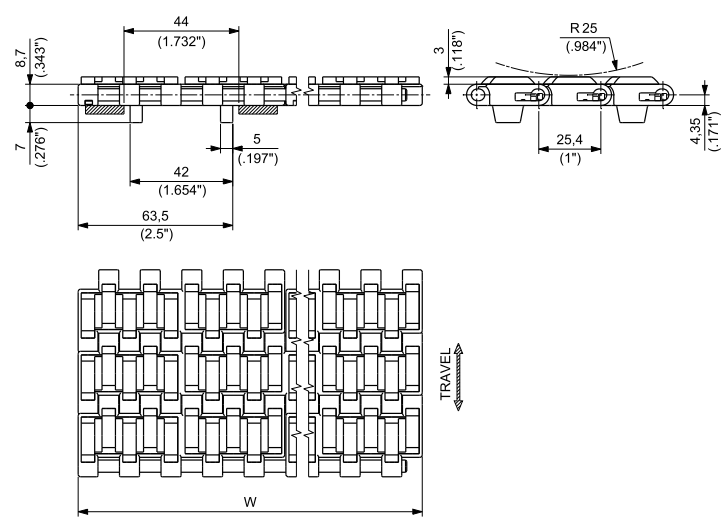

WIDTH W		MATERIALS				Rubber	Pin
		Module		Module			
		<b>ULF</b> ULTRA LOW FRICTION POLYESTER RESIN	<b>PP</b> SPECIAL POLYPROPYLENE*				
		PART NUMBER		PART NUMBER			
mm	inch	WITHOUT TRACKING GUIDE	WITH TRACKING GUIDE	WITHOUT TRACKING GUIDE	WITH TRACKING GUIDE		
85	3.35	<b>HF1600ULF0085</b>	<b>HF1600GULF0085</b>	<b>HF1600APP0085</b>	<b>HF1600AGPP0085</b>	THERMOPLASTIC <b>TPE</b> Hardness: 55 Sha for ULF material 50 Sha for PP material	POM for ULF material PBT for PP material
170	6.69	<b>HF1600ULF0170</b>	<b>HF1600G1ULF0170</b>	<b>HF1600APP0170</b>	<b>HF1600AG1PP0170</b>		
255	10.04	<b>HF1600ULF0255</b>	<b>HF1600G1ULF0255</b>	<b>HF1600APP0255</b>	<b>HF1600AG1PP0255</b>		
340	13.39	<b>HF1600ULF0340</b>	<b>HF1600G1ULF0340</b>	<b>HF1600APP0340</b>	<b>HF1600AG1PP0340</b>		
425	16.73	<b>HF1600ULF0425</b>	<b>HF1600G1ULF0425</b>	<b>HF1600APP0425</b>	<b>HF1600AG1PP0425</b>		
510	20.08	<b>HF1600ULF0510</b>	<b>HF1600G1ULF0510</b>	<b>HF1600APP0510</b>	<b>HF1600AG1PP0510</b>		
595	23.43	<b>HF1600ULF0595</b>	<b>HF1600G1ULF0595</b>	<b>HF1600APP0595</b>	<b>HF1600AG1PP0595</b>		
680	26.77	<b>HF1600ULF0680</b>	<b>HF1600G1ULF0680</b>	<b>HF1600APP0680</b>	<b>HF1600AG1PP0680</b>		
756	30.12	<b>HF1600ULF0765</b>	<b>HF1600G1ULF0765</b>	<b>HF1600APP0765</b>	<b>HF1600AG1PP0765</b>		
850	33.46	<b>HF1600ULF0850</b>	<b>HF1600G1ULF0850</b>	<b>HF1600APP0850</b>	<b>HF1600AG1PP0850</b>		
935	36.81	<b>HF1600ULF0935</b>	<b>HF1600G1ULF0935</b>	<b>HF1600APP0935</b>	<b>HF1600AG1PP0935</b>		
1020	40.16	<b>HF1600ULF1020</b>	<b>HF1600G1ULF1020</b>	<b>HF1600APP1020</b>	<b>HF1600AG1PP1020</b>		

Belts wider than 1020 mm (40.16") are available in 85 mm (3.35") increments.  
To identify the Part Numbers, please substitute the last four digits of the PN with the desired width.  
Example: for a 1105 mm wide belt (=1020+85 mm) without guide, the PN for ULF material is "HF1600ULF1105".  
\*Actual width is larger than the nominal width.



**Standard packaging:**  
Belt widths ≤ 425 mm (16.73") are supplied in rolls of 1,524 m (5 ft) each.  
Belt widths ≥ 510 mm (20.08") are supplied in the length requested by the customer.

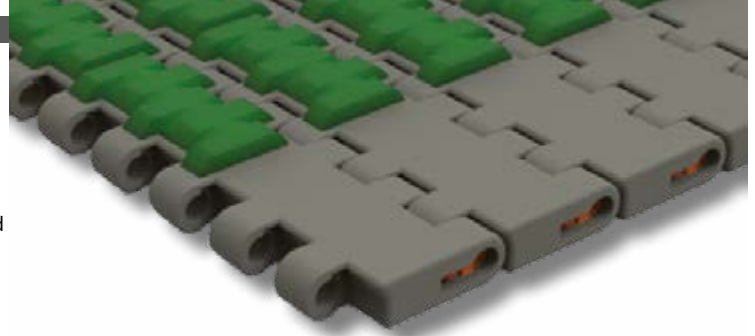

### 8,7 mm (0.343") THICKNESS RUBBERIZED SURFACE - SIDE INDENT

The belt is specifically designed for handling shrink wrapped packs, boxes, plastic trays and other types of containers in incline, decline or timing applications.

- **Belt widths:** 255 mm (10.04") or wider in 85 mm (3.346") increments
- **Working Load (at 25°C/77°F):** 21600 N/m (1,480 lbs/ft) for **ULF** material  
13200 N/m (904 lbs/ft) for **PP** material
- **Belt weight:** 8,91 kg/m<sup>2</sup> (1.82 lbs/ft<sup>2</sup>) for **ULF** material  
6,71 kg/m<sup>2</sup> (1.37 lbs/ft<sup>2</sup>) for **PP** material

VERSION WITHOUT TRACKING GUIDE

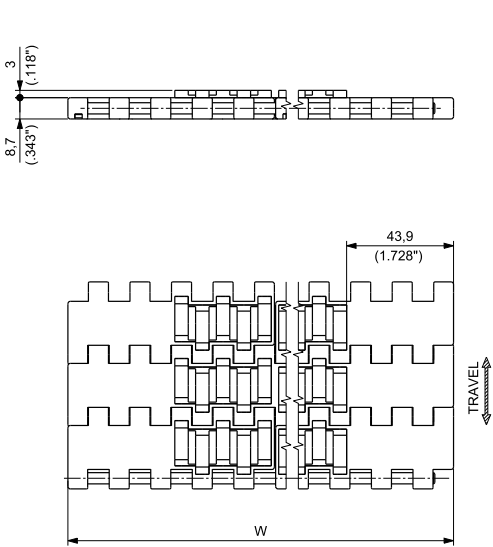

VERSION WITH TRACKING GUIDE

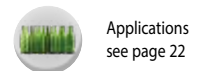
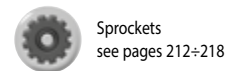
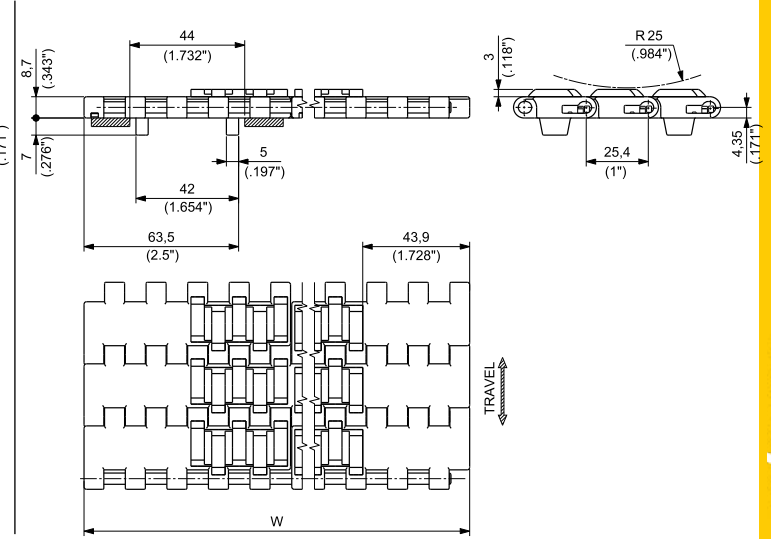

WIDTH W		MATERIALS				Rubber	Pin
		Module					
		<b>ULF</b> ULTRA LOW FRICTION POLYESTER RESIN	<b>PP</b> SPECIAL POLYPROPYLENE*			THERMOPLASTIC <b>TPE</b> Hardness: 55 ShA for ULF material 50 ShA for PP material	POM for ULF material PBT for PP material
		PART NUMBER		PART NUMBER			
mm	inch	WITHOUT TRACKING GUIDE	WITH TRACKING GUIDE	WITHOUT TRACKING GUIDE	WITH TRACKING GUIDE		
255	10.04	<b>HFS1600ULF0255</b>	<b>HFS1600G1ULF0255</b>	<b>HFS1600APP0255</b>	<b>HFS1600AG1PP0255</b>		
340	13.39	<b>HFS1600ULF0340</b>	<b>HFS1600G1ULF0340</b>	<b>HFS1600APP0340</b>	<b>HFS1600AG1PP0340</b>		
425	16.73	<b>HFS1600ULF0425</b>	<b>HFS1600G1ULF0425</b>	<b>HFS1600APP0425</b>	<b>HFS1600AG1PP0425</b>		
510	20.08	<b>HFS1600ULF0510</b>	<b>HFS1600G1ULF0510</b>	<b>HFS1600APP0510</b>	<b>HFS1600AG1PP0510</b>		
595	23.43	<b>HFS1600ULF0595</b>	<b>HFS1600G1ULF0595</b>	<b>HFS1600APP0595</b>	<b>HFS1600AG1PP0595</b>		
680	26.77	<b>HFS1600ULF0680</b>	<b>HFS1600G1ULF0680</b>	<b>HFS1600APP0680</b>	<b>HFS1600AG1PP0680</b>		
765	30.12	<b>HFS1600ULF0765</b>	<b>HFS1600G1ULF0765</b>	<b>HFS1600APP0765</b>	<b>HFS1600AG1PP0765</b>		
850	33.46	<b>HFS1600ULF0850</b>	<b>HFS1600G1ULF0850</b>	<b>HFS1600APP0850</b>	<b>HFS1600AG1PP0850</b>		
935	36.81	<b>HFS1600ULF0935</b>	<b>HFS1600G1ULF0935</b>	<b>HFS1600APP0935</b>	<b>HFS1600AG1PP0935</b>		
1020	40.16	<b>HFS1600ULF1020</b>	<b>HFS1600G1ULF1020</b>	<b>HFS1600APP1020</b>	<b>HFS1600AG1PP1020</b>		

Belts wider than 1020 mm (40.16") are available in 85 mm (3.35") increments.  
To identify the Part Numbers, please substitute the last four digits of the PN with the desired width.  
Example: for a 1105 mm wide belt (=1020+85 mm) without guide, the PN for ULF material is "HFS1600ULF1105".  
\*Actual width is larger than the nominal width.

**Standard packaging:**  
Belt widths ≤ 425 mm (16.73") are supplied in rolls of 1,524 m (5 ft) each.  
Belt widths ≥ 510 mm (20.08") are supplied in the length requested by the customer.

## 8,7 mm (0.343") THICKNESS RAISED RIB

The ideal ratio rib thickness/spacing offers high support even for the most unstable products, such as PET bottles with petaloid bottom, cans, 3-piece cans. Optimum liquid drainage and good mechanical strength.

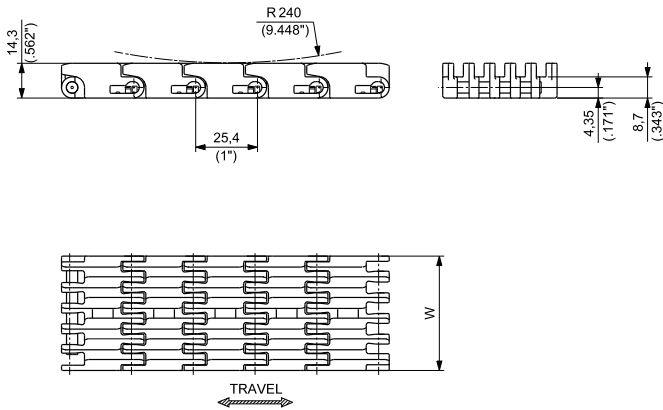
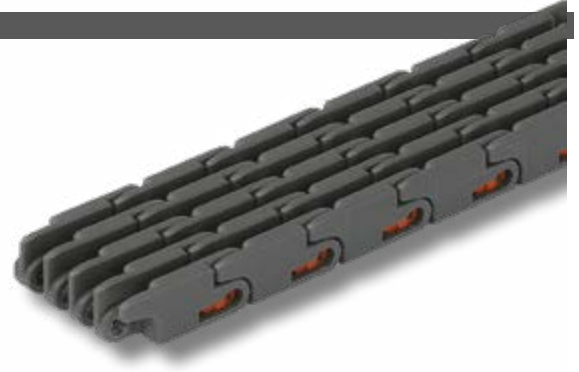

Materials  
see page 12



Combs  
see page 209



Sprockets  
see pages 212÷218



Applications  
see page 22

MATERIALS		ITEM DESCRIPTION	PART NUMBER	WIDTH W		PLATE THICKNESS		WORKING LOAD (25°C/77°F)		WEIGHT	
Plate	Pin			mm	inch	mm	inch	N	lbs	kg/m	lbs/ft
ULTRA PERFORMANCE HOMOPOLYMER DELRIN® <b>UP</b>	PBT	RR1600A UP K 30	R1600AUPKMA/000	30,0	1.18	8,7	0.343	700	157	0,39	0.26
		RR1600A UP K 38,5	R1600AUPKMB/000	38,5	1.52	8,7	0.343	950	214	0,49	0.33
		RR1600A UP K 47	R1600AUPKMB/000	47,0	1.85	8,7	0.343	1150	259	0,60	0.40
		RR1600A UP K 58	R1600AUPKPB/000	58,0	2.28	8,7	0.343	1400	315	0,75	0.50
SPECIAL POLYPROPYLENE* <b>PP</b>	PBT	RR1600A PP K 30	R1600APPKMA/000	30,0	1.18	8,7	0.343	700	157	0,26	0.17
		RR1600A PP K 38,5	R1600APPKMB/000	38,5	1.52	8,7	0.343	950	214	0,33	0.22
		RR1600A PP K 47	R1600APPKMB/000	47,0	1.85	8,7	0.343	1150	259	0,40	0.27
		RR1600A PP K 58	R1600APPKPB/000	58,0	2.28	8,7	0.343	1400	315	0,49	0.33

\*Actual width is larger than the nominal width.



Standard packaging:  
Rolls of 3,048 m (10 feet)

## TRANSFER COMBS

Combs are supplied with slot covers but without fastening screws.  
One fastening screw is required for each comb.  
It can be ordered using P/N 16300020.



### MATERIALS

COMBS: **DG** ACETAL RESIN

SCREWS\*: **SS** STAINLESS STEEL

\*Screws are not included in the combs.

COMB FOR K 58 CHAIN

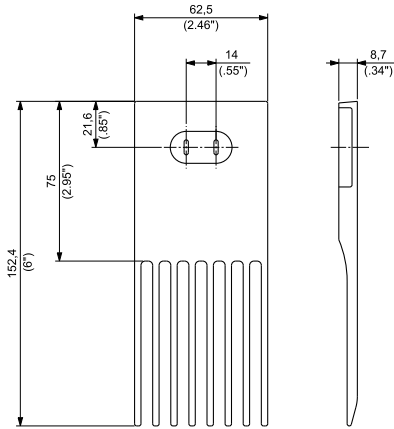

PART NUMBER **TC1600-01**

COMB FOR K 47 CHAIN

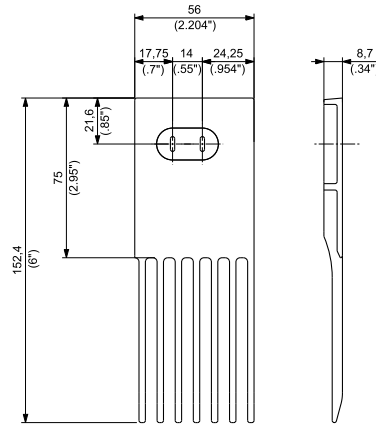

PART NUMBER **TC1600-02**

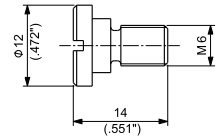

COMB FOR K 38,5 CHAIN

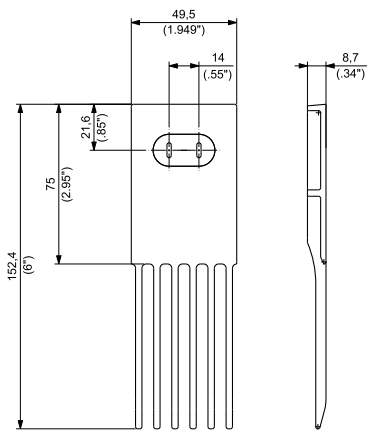

PART NUMBER **TC1600-03**

COMB FOR K 30 CHAIN

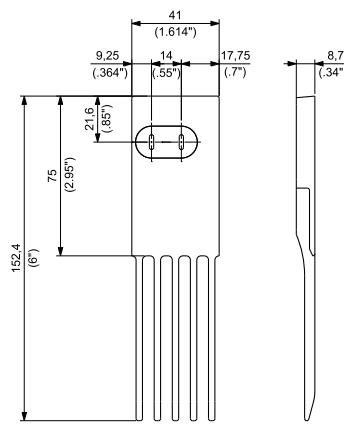

PART NUMBER **TC1600-04**

PART NUMBER **16300020**

### 9,6 mm (0.378") THICKNESS RAISED RIB

This belt allows the head transfer of the products by using transfer combs and has a open area to allow liquid drainage and belt cleaning. Particularly suitable for product infeed of packaging machines.

- **Belt widths:** 152,4 mm (6") or wider in 76,2 mm (3") increments
- **Working Load (at 25°C/77°F):** 21580 N/m (1,480 lbs/ft) for **UP** material  
10920 N/m (748 lbs/ft) for **PP** material
- **Belt weight:** 9,27 kg/m<sup>2</sup> (1.90 lbs/ft<sup>2</sup>) for **UP** material  
6,16 kg/m<sup>2</sup> (1.26 lbs/ft<sup>2</sup>) for **PP** material

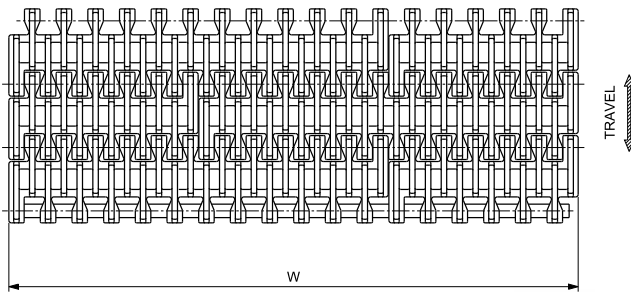
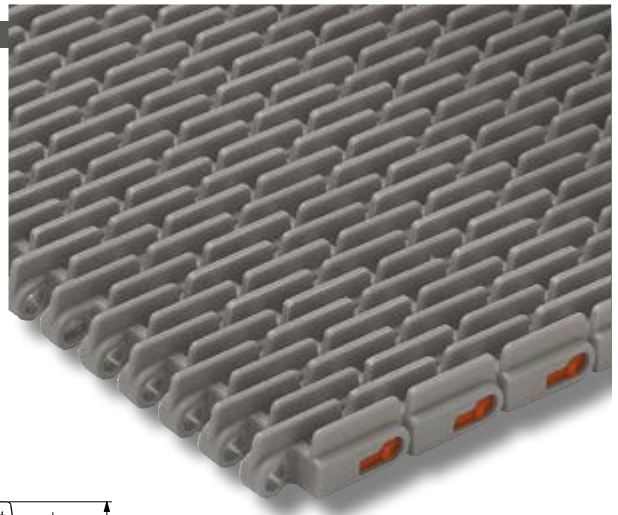
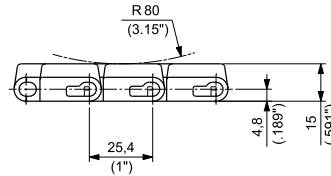
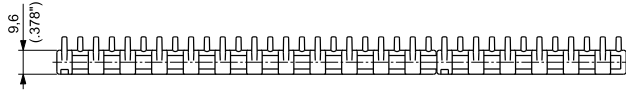

Materials see page 12



Combs see page 211



Sprockets see pages 212÷218



Applications see page 22

WIDTH W		MATERIALS		
		Module		Pin
		UP ULTRA PERFORMANCE HOMOPOLYMER DELRIN®	PP SPECIAL POLYPROPYLENE*	
mm	inch	PART NUMBER	PART NUMBER	
152,4	6	<b>1110UP006</b>	<b>1110PP006</b>	POLYPROPYLENE
228,6	9	<b>1110UP009</b>	<b>1110PP009</b>	
304,8	12	<b>1110UP012</b>	<b>1110PP012</b>	
381,0	15	<b>1110UP015</b>	<b>1110PP015</b>	
457,2	18	<b>1110UP018</b>	<b>1110PP018</b>	
533,4	21	<b>1110UP021</b>	<b>1110PP021</b>	
609,6	24	<b>1110UP024</b>	<b>1110PP024</b>	
685,8	27	<b>1110UP027</b>	<b>1110PP027</b>	
762,0	30	<b>1110UP030</b>	<b>1110PP030</b>	
838,2	33	<b>1110UP033</b>	<b>1110PP033</b>	
914,4	36	<b>1110UP036</b>	<b>1110PP036</b>	
990,6	39	<b>1110UP039</b>	<b>1110PP039</b>	
1066,8	42	<b>1110UP042</b>	<b>1110PP042</b>	
1143,0	45	<b>1110UP045</b>	<b>1110PP045</b>	
1219,2	48	<b>1110UP048</b>	<b>1110PP048</b>	
1295,4	51	<b>1110UP051</b>	<b>1110PP051</b>	
1371,6	54	<b>1110UP054</b>	<b>1110PP054</b>	
1447,8	57	<b>1110UP057</b>	<b>1110PP057</b>	
1524,0	60	<b>1110UP060</b>	<b>1110PP060</b>	

Belts wider than 1524 mm (60") are available in 76,2 mm (3") increments.  
To identify the Part Numbers, please substitute the last three digits of the PN with the desired width.  
Example: for a 63" wide belt (=60+3 inches), the PN for PP material is "1110PP063".  
\*Actual width is larger than the nominal width.



Standard packaging:  
Belts are supplied in the length requested by the customer.

## TRANSFER COMBS

Combs are supplied with slot covers but without fastening screws.  
Two fastening screws are required for each comb.  
They can be ordered using P/N 16300020.

Special note: the comb fastening screws for 1110 belts are not interchangeable with fastening screws for 3125 belts.

### MATERIALS

COMBS: **DG** ACETAL RESIN

SCREWS\*: **SS** STAINLESS STEEL

\*Screws are not included in the combs.

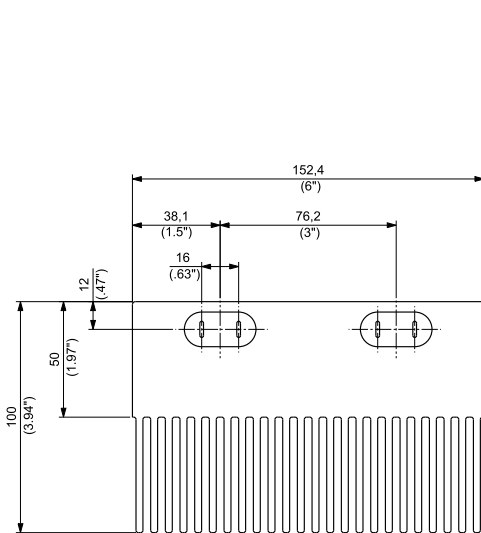

PART NUMBER **TC1110-01**

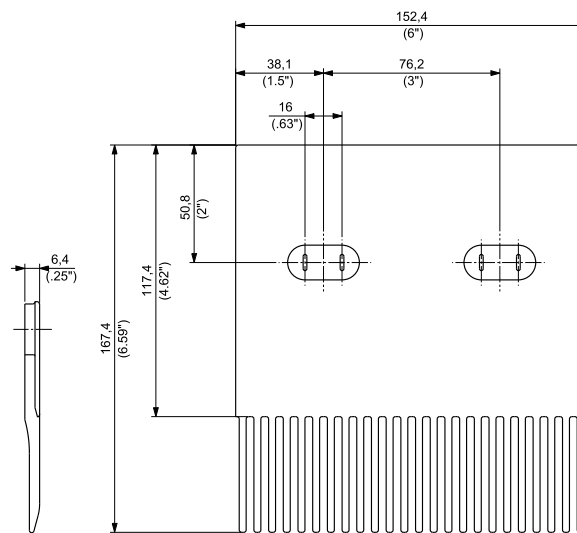

PART NUMBER **TC1110-02**

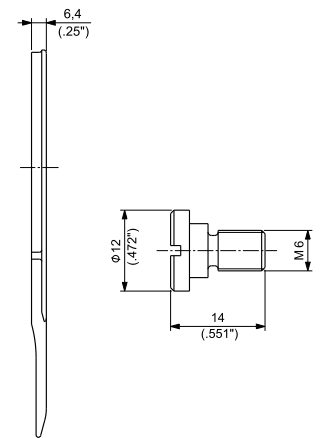

PART NUMBER **16300020**



## SUITABLE FOR CHAINS:

- 1500
- 1600
- HF 1600
- HFS 1600
- RR 1500
- RR 1600
- 1110

## MATERIALS

SPROCKETS: **PGF** REINFORCED POLYAMIDE



## 8T & 12T SPROCKETS

(for 13T, 18T, 19T & 21T see next pages)

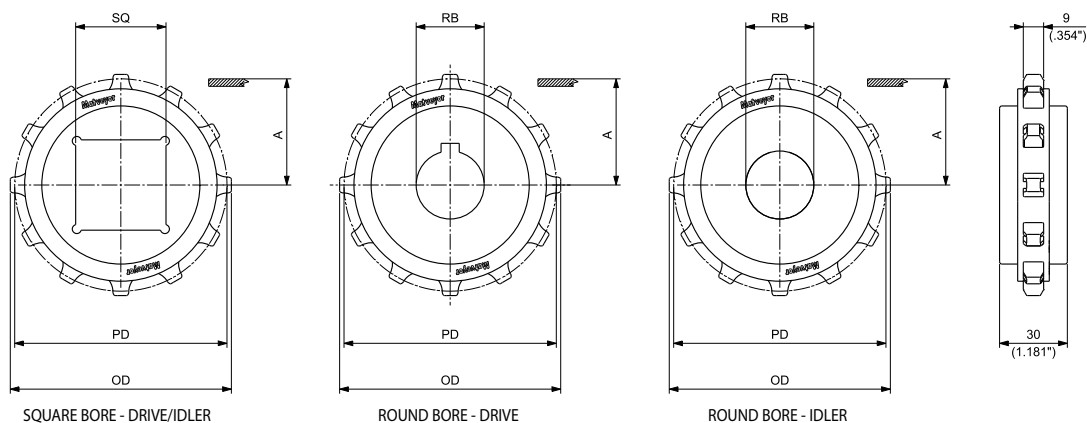

NOTE: FOR 8T SPROCKET, THE HUB WIDTH IS 25 mm (0.984")

## MOULDED SOLID DRIVE AND IDLER SPROCKETS

N. TEETH	PITCH DIAMETER PD		OUTSIDE DIAMETER OD		WEAR STRIP POSITIONING A		BORE SIZE*		PART NUMBER			WEIGHT	
	mm	inch	mm	inch	mm	inch	SQUARE BORE SQ		ROUND BORE RB		Kg	lbs	
							DRIVE/IDLER	DRIVE	IDLER				
8	66,37	2.613	64,50	2.539	28,80	1.134	20		<b>MPBT10100820</b>	<b>MPBF10100820</b>	0,05	0.11	
							25		<b>MPBT10100825</b>	<b>MPBF10100825</b>	0,04	0.10	
							30		<b>MPBT10100830</b>	<b>MPBF10100830</b>	0,04	0.08	
							1¼		<b>MPBT101008254</b>	<b>MPBF101008254</b>	0,04	0.10	
							1½		<b>MPBT101008317</b>	<b>MPBF101008317</b>	0,03	0.07	
12	98,14	3.864	97,90	3.854	44,70	1.760	30		<b>MPBT10101230</b>	<b>MPBF10101230</b>	0,14	0.30	
							35		<b>MPBT10101235</b>	<b>MPBF10101235</b>	0,13	0.28	
							40	<b>MPBQ10101240</b>	<b>MPBT10101240</b>	<b>MPBF10101240</b>	0,12	0.27	
							1¾		<b>MPBT101012301</b>	<b>MPBF101012301</b>	0,14	0.30	
							17/16		<b>MPBT101012365</b>	<b>MPBF101012365</b>	0,12	0.27	
					1½		<b>MPBT101012381</b>	<b>MPBF101012381</b>	0,12	0.26			

\*In case of round bore, diameter is indicated. In case of square bore, side of the square is indicated.

## SUITABLE FOR CHAINS:

- 1500
- 1600
- HF 1600
- HFS 1600
- RR 1500
- RR 1600
- 1110

## MATERIALS

SPROCKETS: **PGF** REINFORCED POLYAMIDE



## 13T & 18T SPROCKETS

(for 19T & 21T see next page, for 8T & 12T see previous page)

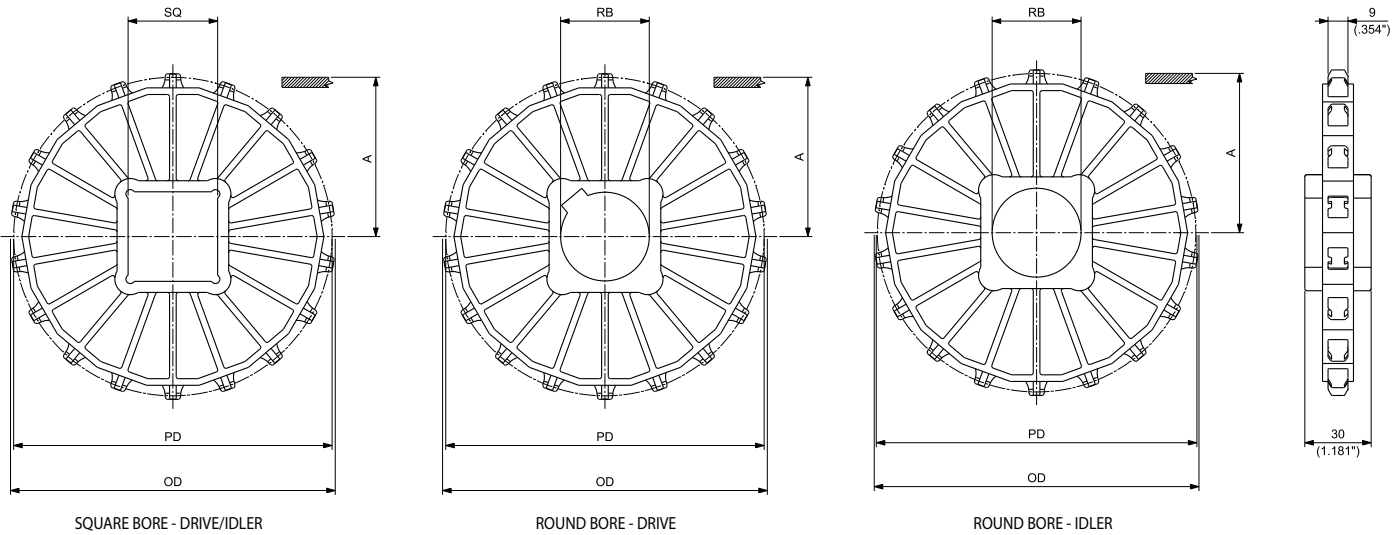

## MOULDED SOLID DRIVE AND IDLER SPROCKETS

N. TEETH	PITCH DIAMETER PD		OUTSIDE DIAMETER OD		WEAR STRIP POSITIONING A		BORE SIZE*		PART NUMBER			WEIGHT	
	mm	inch	mm	inch	mm	inch	mm	inch	SQUARE BORE SQ DRIVE/IDLER	ROUND BORE RB DRIVE	ROUND BORE RB IDLER	Kg	lbs
13	106,14	4.179	106,20	4.181	48,70	1.917	30			MPBT10101330	MPBF10101330	0,17	0.38
							35			MPBT10101335	MPBF10101335	0,15	0.33
							40	MPBQ10101340	MPBT10101340	MPBF10101340	0,16	0.36	
							1 <sup>3</sup> / <sub>16</sub>			MPBT101013301	MPBF101013301	0,17	0.38
							1 <sup>7</sup> / <sub>16</sub>			MPBT101013365	MPBF101013365	0,16	0.35
							1 <sup>1</sup> / <sub>2</sub>	MPBQ10101381	MPBT101013381	MPBF101013381	0,15	0.34	
18	146,27	5.759	147,20	5.795	68,80	2.709	30			MPBT10101830	MPBF10101830	0,19	0.41
							35			MPBT10101835	MPBF10101835	0,21	0.47
							40	MPBQ10101840	MPBT10101840	MPBF10101840	0,20	0.44	
							60	MPBQ10101860			0,16	0.36	
							1 <sup>3</sup> / <sub>16</sub>			MPBT101018301		0,21	0.46
							1 <sup>7</sup> / <sub>16</sub>			MPBT101018365	MPBF101018365	0,20	0.43
1 <sup>1</sup> / <sub>2</sub>			MPBT101018381	MPBF101018381	0,19	0.42							

\*In case of round bore, diameter is indicated. In case of square bore, side of the square is indicated.

## SUITABLE FOR CHAINS:

- 1500
- 1600
- HF 1600
- HFS 1600
- RR 1500
- RR 1600
- 1110

## MATERIALS

SPROCKETS: **PGF** REINFORCED POLYAMIDE



## 19T & 21T SPROCKETS

(for 8T, 12T, 13T & 18T see previous pages)

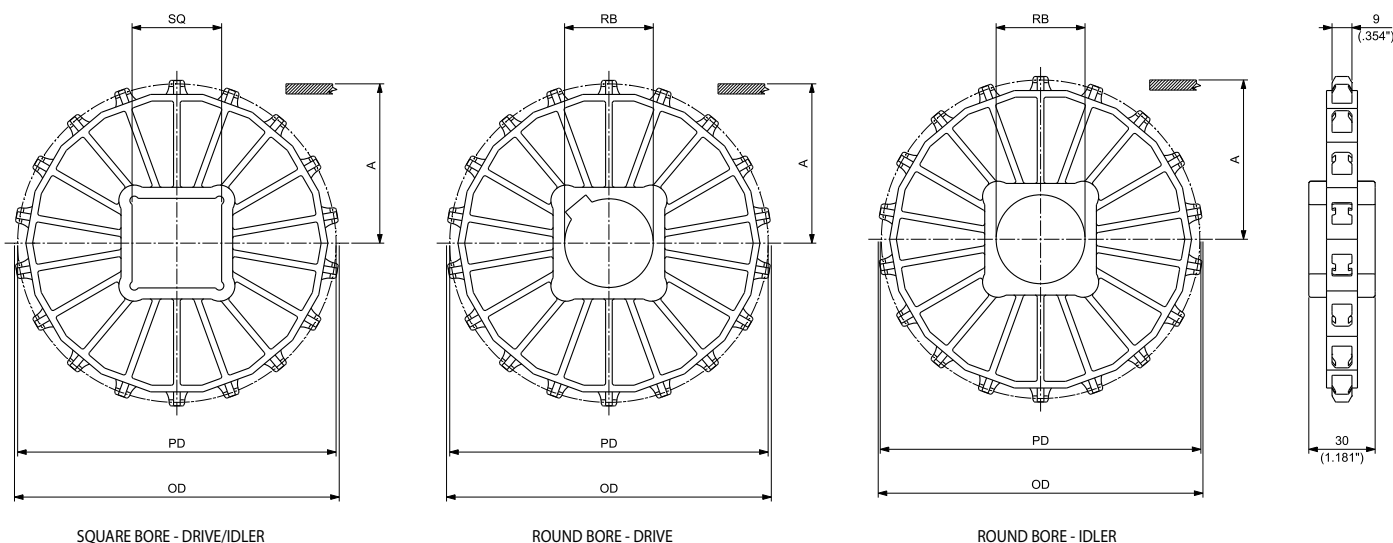

## MOULDED SOLID DRIVE AND IDLER SPROCKETS

N. TEETH	PITCH DIAMETER PD		OUTSIDE DIAMETER OD		WEAR STRIP POSITIONING A		BORE SIZE*		PART NUMBER			WEIGHT	
	mm	inch	mm	inch	mm	inch	mm	inch	SQUARE BORE SQ DRIVE/IDLER	ROUND BORE RB DRIVE	ROUND BORE RB IDLER	Kg	lbs
19	154,32	6.076	155,30	6.114	72,80	2.866	30			MPBT10101930	MPBF10101930	0,18	0.41
							35			MPBT10101935	MPBF10101935	0,17	0.38
							40	MPBQ10101940	MPBT10101940	MPBF10101940	0,16	0.35	
							50			MPBT10101950	MPBF10101950	0,19	0.42
							60	MPBQ10101960	MPBT10101960	MPBF10101960	0,15	0.34	
							65	MPBQ10101965			0,17	0.37	
							1			MPBT101019254	MPBF101019254	0,19	0.43
							1 3/16			MPBT101019301	MPBF101019301	0,18	0.41
							1 7/16			MPBT101019365	MPBF101019365	0,17	0.37
							1 1/2	MPBQ101019381	MPBT101019381	MPBF101019381	0,17	0.36	
2 1/2	MPBQ101019635			0,17	0.37								
21	170,42	6.709	171,60	6.756	80,90	3.185	30			MPBT10102130	MPBF10102130	0,27	0.59
							35			MPBT10102135	MPBF10102135	0,26	0.57
							40	MPBQ10102140	MPBT10102140	MPBF10102140	0,25	0.54	
							50			MPBT10102150	MPBF10102150	0,29	0.64
							60	MPBQ10102160			0,22	0.49	
							1 3/16			MPBT101021301	MPBF101021301	0,27	0.59
							1 7/16			MPBT101021365	MPBF101021365	0,25	0.56
							1 1/2	MPBQ101021381	MPBT101021381	MPBF101021381	0,25	0.55	

\*In case of round bore, diameter is indicated. In case of square bore, side of the square is indicated.

## SUITABLE FOR CHAINS:

- 1500
- 1600
- HF 1600
- HFS 1600
- RR 1500
- RR 1600
- 1110

## MATERIALS

SPROCKETS: **PA** POLYAMIDE

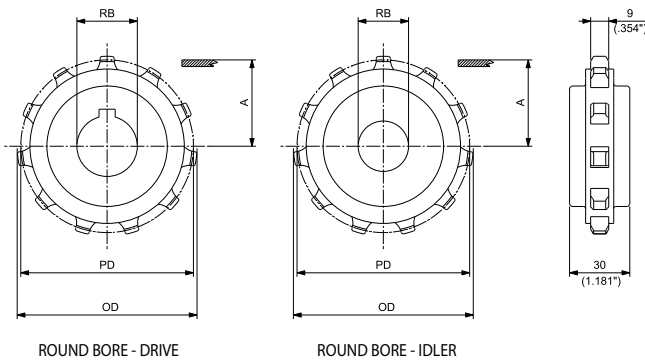

## MACHINED SOLID DRIVE AND IDLER SPROCKETS

N. TEETH	PITCH DIAMETER PD		OUTSIDE DIAMETER OD		WEAR STRIP POSITIONING A		BORE SIZE*		PART NUMBER ROUND BORE RB		WEIGHT	
	mm	inch	mm	inch	mm	inch	mm	inch**	DRIVE	IDLER	Kg	lbs
10	82,20	3.236	81,30	3.201	36,70	1.445	25		<b>MPBAT10101025</b>	<b>MPBAF10101025</b>	0,09	0.19
							30		<b>MPBAT10101030</b>	<b>MPBAF10101030</b>	0,08	0.18
								1	<b>MPBAT101010254</b>	<b>MPBAF101010254</b>	0,09	0.19
								1¼	<b>MPBAT101010317</b>	<b>MPBAF101010317</b>	0,08	0.17
								1½	<b>MPBAT101010381</b>	<b>MPBAF101010381</b>	0,07	0.14
11	90,16	3.550	89,60	3.528	40,70	1.602	25		<b>MPBAT10101125</b>	<b>MPBAF10101125</b>	0,11	0.25
							30		<b>MPBAT10101130</b>	<b>MPBAF10101130</b>	0,11	0.23
								1	<b>MPBAT101011254</b>	<b>MPBAF101011254</b>	0,11	0.25
								1¼	<b>MPBAT101011317</b>	<b>MPBAF101011317</b>	0,10	0.23
								1½	<b>MPBAT101011381</b>	<b>MPBAF101011381</b>	0,09	0.20

\*Diameter is indicated.

\*\* Imperial round bore drive sprockets are supplied with setscrew. Metric round bore drive sprockets are supplied without setscrew.

## SUITABLE FOR CHAINS:

- 1500
- 1600
- HF 1600
- HFS 1600
- RR 1500
- RR 1600
- 1110

MATERIALS	
SPROCKETS:	<b>PGF</b> REINFORCED POLYAMIDE
SCREW:	<b>SS</b> STAINLESS STEEL
NUTS:	<b>S+NC</b> ZINC PLATED STEEL



## 16T & 18T SPROCKETS

(for 19T & 20T see next page)

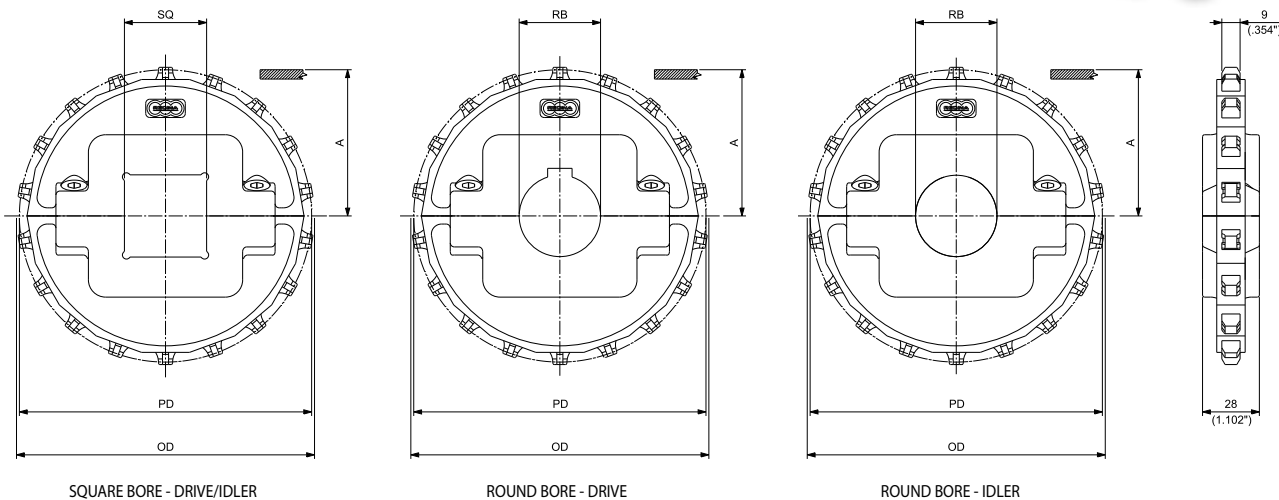

SQUARE BORE - DRIVE/IDLER

ROUND BORE - DRIVE

ROUND BORE - IDLER

## MOULDED SPLIT DRIVE AND IDLER SPROCKETS

N. TEETH	PITCH DIAMETER PD		OUTSIDE DIAMETER OD		WEAR STRIP POSITIONING A		BORE SIZE* mm inch**	PART NUMBER			WEIGHT	
	mm	inch	mm	inch	mm	inch		SQUARE BORE SQ DRIVE/IDLER	ROUND BORE RB DRIVE	ROUND BORE RB IDLER	Kg	lbs
16	130,20	5.126	130,10	5.122	60,70	2.390	30		MPBST10101630	MPBSF10101630	0,27	0.59
							35		MPBST10101635	MPBSF10101635	0,26	0.58
							40	MPBSQ10101640	MPBST10101640	MPBSF10101640	0,25	0.56
							45		MPBST10101645	MPBSF10101645	0,25	0.54
							50	MPBSQ10101650	MPBST10101650	MPBSF10101650	0,24	0.52
							60	MPBSQ10101660			0,19	0.42
							1		MPBST101016254	MPBSF101016254	0,27	0.61
							1 3/16		MPBST101016301	MPBSF101016301	0,27	0.59
							1 1/4		MPBST101016317	MPBSF101016317	0,27	0.59
							1 7/16		MPBST101016365	MPBSF101016365	0,26	0.57
1 1/2	MPBSQ101016381	MPBST101016381	MPBSF101016381	0,26	0.57							
18	146,27	5.759	146,50	5.768	68,80	2.709	30		MPBST10101830	MPBSF10101830	0,32	0.71
							35		MPBST10101835	MPBSF10101835	0,32	0.70
							40	MPBSQ10101840	MPBST10101840	MPBSF10101840	0,31	0.68
							45		MPBST10101845	MPBSF10101845	0,30	0.66
							50	MPBSQ10101850	MPBST10101850	MPBSF10101850	0,29	0.64
							60	MPBSQ10101860	MPBST10101860	MPBSF10101860	0,27	0.59
							1		MPBST101018254	MPBSF101018254	0,33	0.72
							1 3/16		MPBST101018301	MPBSF101018301	0,32	0.71
							1 1/4		MPBST101018317	MPBSF101018317	0,32	0.71
							1 7/16		MPBST101018365	MPBSF101018365	0,31	0.69
							1 1/2	MPBSQ101018381	MPBST101018381	MPBSF101018381	0,31	0.69
							2		MPBST101018508	MPBSF101018508	0,29	0.63

\*In case of round bore, diameter is indicated. In case of square bore, side of the square is indicated.

\*\* Imperial round bore drive sprockets are supplied with setscrew. Metric round bore drive sprockets are supplied without setscrew.

## SUITABLE FOR CHAINS:

- 1500
- 1600
- HF 1600
- HFS 1600
- RR 1500
- RR 1600
- 1110

MATERIALS	
SPROCKETS:	<b>PGF</b> REINFORCED POLYAMIDE
SCREW:	<b>SS</b> STAINLESS STEEL
NUTS:	<b>S+NC</b> ZINC PLATED STEEL



## 19T & 20T SPROCKETS

(for 16T & 18T see previous page)

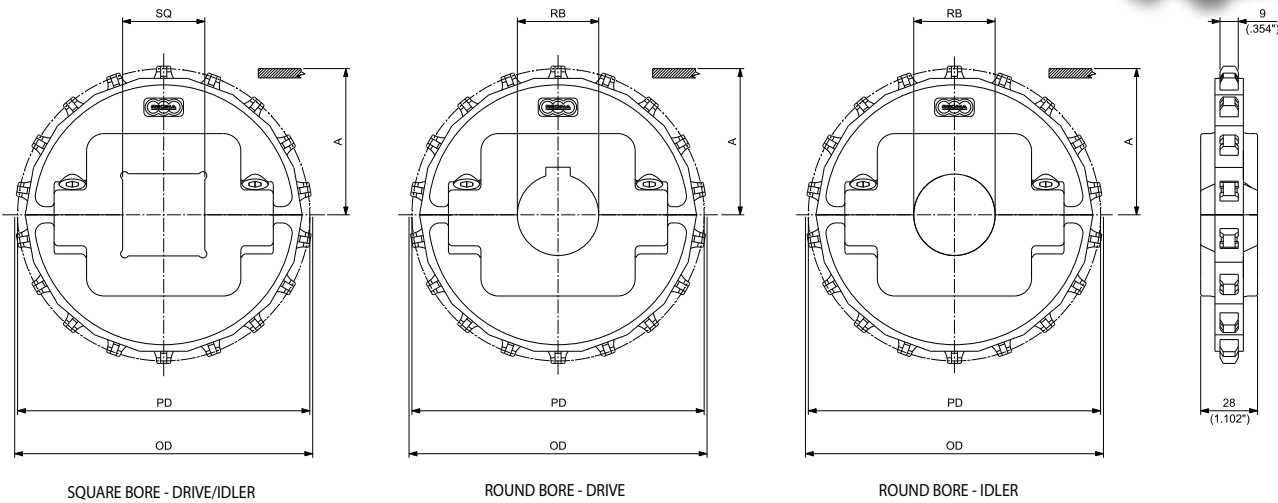

## MOULDED SPLIT DRIVE AND IDLER SPROCKETS

N. TEETH	PITCH DIAMETER PD		OUTSIDE DIAMETER OD		WEAR STRIP POSITIONING A		BORE SIZE*		PART NUMBER			WEIGHT	
	mm	inch	mm	inch	mm	inch	mm	inch**	SQUARE BORE SQ DRIVE/IDLER	ROUND BORE RB DRIVE	ROUND BORE RB IDLER	Kg	lbs
19	154,32	6.076	154,60	6.087	72,80	2.866	30		MPBST10101930	MPBSF10101930		0,33	0.72
							35		MPBST10101935	MPBSF10101935		0,32	0.71
							40	MPBSQ10101940	MPBST10101940	MPBSF10101940		0,31	0.69
							45		MPBST10101945	MPBSF10101945		0,30	0.67
							50	MPBSQ10101950	MPBST10101950	MPBSF10101950		0,30	0.65
							60	MPBSQ10101960	MPBST10101960	MPBSF10101960		0,27	0.61
							1		MPBST101019254	MPBSF101019254		0,35	0.77
							1 3/16		MPBST101019301	MPBSF101019301		0,33	0.72
							1 1/4		MPBST101019317	MPBSF101019317		0,32	0.71
							1 7/16		MPBST101019365	MPBSF101019365		0,32	0.70
							1 1/2	MPBSQ101019381	MPBST101019381	MPBSF101019381		0,32	0.70
							2		MPBST101019508	MPBSF101019508		0,28	0.62
							2 1/2	MPBSQ101019635				0,25	0.54
							20	162,37	6.393	162,80	6.409	76,80	3.024
35		MPBST10102035	MPBSF10102035		0,35	0.77							
40	MPBSQ10102040	MPBST10102040	MPBSF10102040		0,34	0.75							
50		MPBST10102050	MPBSF10102050		0,32	0.71							
60	MPBSQ10102060	MPBST10102060	MPBSF10102060		0,30	0.66							
65	MPBSQ10102065				0,26	0.58							
1		MPBST101020254	MPBSF101020254		0,36	0.79							
1 3/16		MPBST101020301	MPBSF101020301		0,35	0.78							
1 1/4		MPBST101020317	MPBSF101020317		0,35	0.78							
1 7/16		MPBST101020365	MPBSF101020365		0,35	0.76							
1 1/2	MPBSQ101020381	MPBST101020381	MPBSF101020381		0,34	0.76							
2		MPBST101020508	MPBSF101020508		0,32	0.71							
2 1/2	MPBSQ101020635				0,27	0.59							

\*In case of round bore, diameter is indicated. In case of square bore, side of the square is indicated.

\*\* Imperial round bore drive sprockets are supplied with setscrew. Metric round bore drive sprockets are supplied without setscrew.



## SUITABLE FOR CHAINS:

- 1500
- 1600
- HF 1600
- HFS 1600
- RR 1500
- RR 1600
- 1110

### MATERIALS

SPROCKETS:	<b>PA</b>	POLYAMIDE
SCREWS:	<b>SS</b>	STAINLESS STEEL
NUTS:	<b>B</b>	BRASS

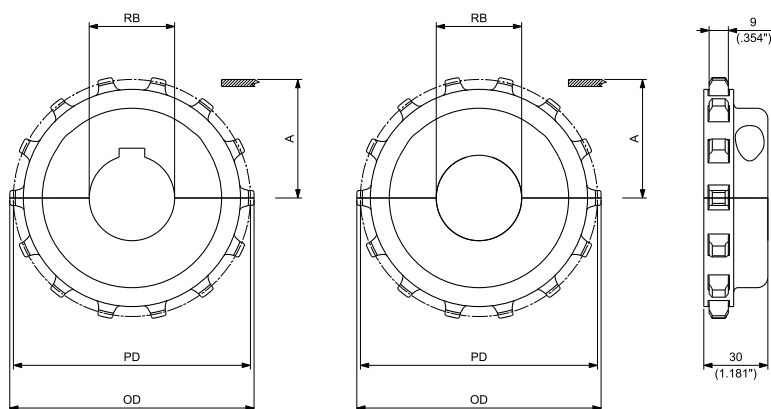

ROUND BORE - DRIVE

ROUND BORE - IDLER



**MOULDED SOLID IDLER WHEELS**  
SEE PAGE 124



**MOULDED SPLIT IDLER WHEELS**  
SEE PAGE 193



**MACHINED SPLIT IDLER WHEELS**  
SEE PAGE 125

## MACHINED SPLIT DRIVE AND IDLER SPROCKETS

N. TEETH	PITCH DIAMETER PD		OUTSIDE DIAMETER OD		WEAR STRIP POSITIONING A		BORE SIZE*		PART NUMBER ROUND BORE RB		WEIGHT		
	mm	inch	mm	inch	mm	inch	mm	inch**	DRIVE	IDLER	Kg	lbs	
14	114,15	4.494	114,40	4.504	52,70	2.075	1		25	MPBAST10101425	MPBASF10101425	0,26	0.57
									30	MPBAST10101430	MPBASF10101430	0,25	0.55
									35	MPBAST10101435	MPBASF10101435	0,24	0.53
									40	MPBAST10101440	MPBASF10101440	0,23	0.51
									1 3/16	MPBAST101014254	MPBASF101014254	0,26	0.56
									1 1/4	MPBAST101014301	MPBASF101014301	0,25	0.55
									1 1/4	MPBAST101014317	MPBASF101014317	0,25	0.54
									1 7/16	MPBAST101014365	MPBASF101014365	0,24	0.52
									1 1/2	MPBAST101014381	MPBASF101014381	0,23	0.52

\*Diameter is indicated.

\*\* Imperial round bore drive sprockets are supplied with setscrew. Metric round bore drive sprockets are supplied without setscrew.



PERFORMANCE IN MOTION

# Matveyor<sup>®</sup>

## 3/4" Pitch Medium Duty Belts and Chains



## INDUSTRIES AND APPLICATIONS

Suitable for handling loose & packaged products, such as plastic & glass bottles and aluminium & steel cans, in medium duty applications.

### INDUSTRIES

Bottling and canning  
 Food filling  
 Container manufacturing  
 Pharmaceutical  
 Paper/cardboard  
 Consumer goods

### APPLICATIONS

Depalletizer  
 Pressureless Inliners and Combiners  
 Single lane & mass conveyors  
 Accumulation tables  
 Infeed packaging machines  
 Case conveyors  
 Palletizers

## FEATURES

- Smooth and uniform top surface, thanks to location of retention clip underneath modules and reduced gaps between hinges.



- Maximized bottom sliding surface to guarantee limited wear.

- The optimized design and location of retention clip, which can be easily rotated from both the bottom and the side of the belt, results in an easy belt assembly and disassembly.



- The belts can be used on conveyors side by side with Magnetic or TAB sideflexing chains 782 or 783 series allowing a smooth products transfer between straight running and sideflexing conveyors.

### 8,7 mm (0.343") THICKNESS SOLID TOP

Extremely good flatness, manufacturing accuracy, and low coefficient of friction, make the side transfer of the products very easy. Completely closed surface, no gap between the modules, even when engaging on the sprockets.

Particularly suitable for glass products, small sized products and unstable containers (for example PET bottles with petaloid base).

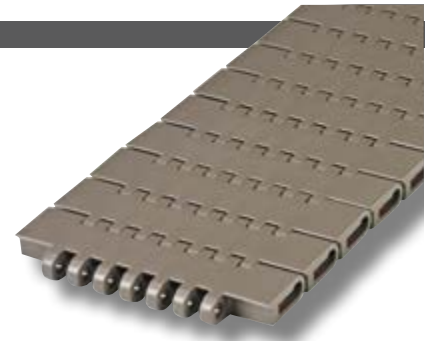

VERSION WITHOUT TRACKING GUIDE

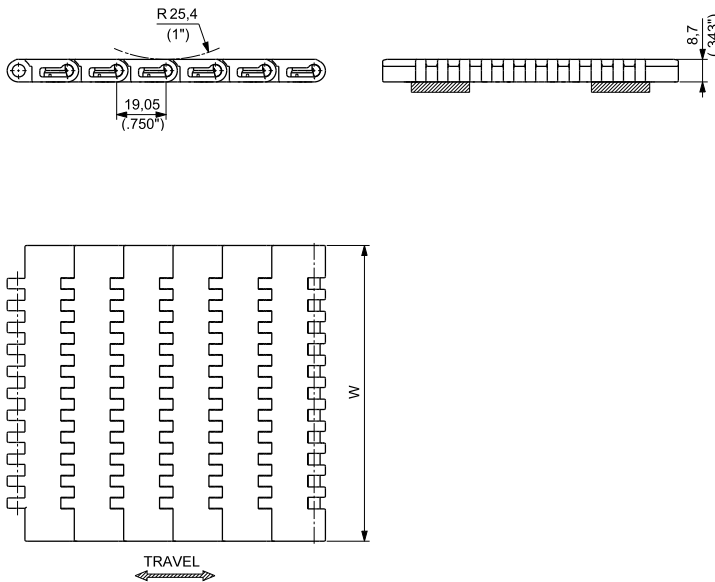

VERSION WITH TRACKING GUIDE

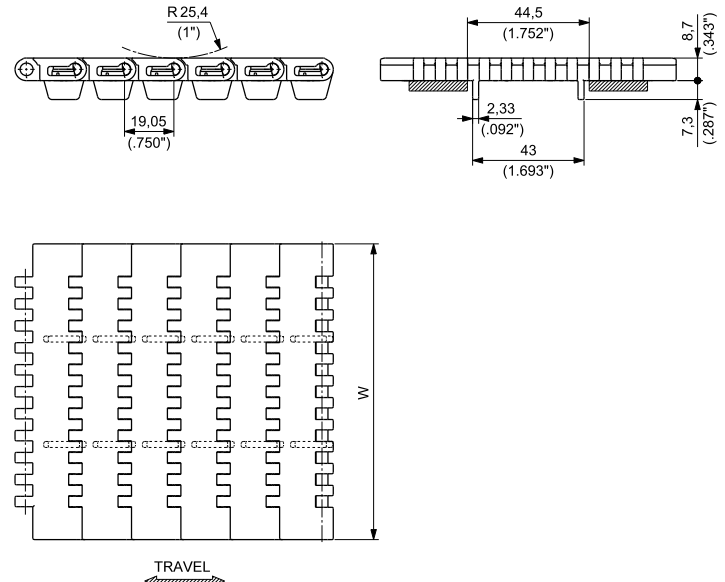

Materials see page 12



Sprockets see pages 226+228



Applications see page 22

MATERIALS		VERSION	ITEM DESCRIPTION	PART NUMBER	WIDTH W		PLATE THICKNESS		WORKING LOAD (25°C/77°F)		WEIGHT	
Plate	Pin				mm	inch	mm	inch	N	lbs	kg/m	lbs/ft
ULTRA PERFORMANCE HOMOPOLYMER DELRIN® <b>UP</b>		WITHOUT TRACKING GUIDE	7300 UP 325	7300UPKD/000	82,6	3.25	8,7	0.343	2300	517	0,84	0.57
			7300 UP 450	7300UPKG/000	114,3	4.50	8,7	0.343	3290	740	1,15	0.77
			7300 UP 600	7300UPKH/000	152,4	6.00	8,7	0.343	4370	982	1,51	1.01
			7300 UP 750	7300UPKL/000	190,5	7.50	8,7	0.343	5450	1225	1,87	1.26
SPECIAL DELRIN® REINFORCED WITH KEVLAR® <b>DK2</b>	PBT		7300 D2K 325	7300D2KKD/000	82,6	3.25	8,7	0.343	2300	517	0,84	0.57
			7300 D2K 450	7300D2KKG/000	114,3	4.50	8,7	0.343	3290	740	1,15	0.77
			7300 D2K 600	7300D2KKH/000	152,4	6.00	8,7	0.343	4370	982	1,51	1.01
			7300 D2K 750	7300D2KKL/000	190,5	7.50	8,7	0.343	5450	1225	1,87	1.26
ECOLOGICAL FRICTION ABATING THERMOPLASTIC <b>e-F.A.S.T.</b>		7300 EF 325	7300EFKD/000	82,6	3.25	8,7	0.343	2300	517	0,84	0.57	
		7300 EF 450	7300EFGK/000	114,3	4.50	8,7	0.343	3290	740	1,15	0.77	
		7300 EF 600	7300EFKH/000	152,4	6.00	8,7	0.343	4370	982	1,51	1.01	
		7300 EF 750	7300EFKL/000	190,5	7.50	8,7	0.343	5450	1225	1,87	1.26	
ULTRA PERFORMANCE HOMOPOLYMER DELRIN® <b>UP</b>		WITH TRACKING GUIDE	7300G UP 325	7300GUPKD/000	82,6	3.25	8,7	0.343	2300	517	0,84	0.57
			7300G UP 450	7300GUPKG/000	114,3	4.50	8,7	0.343	3290	740	1,15	0.77
			7300G UP 600	7300GUPKH/000	152,4	6.00	8,7	0.343	4370	982	1,51	1.01
			7300G UP 750	7300GUPKL/000	190,5	7.50	8,7	0.343	5450	1225	1,87	1.26
SPECIAL DELRIN® REINFORCED WITH KEVLAR® <b>DK2</b>	PBT		7300G D2K 325	7300GD2KKD/000	82,6	3.25	8,7	0.343	2300	517	0,84	0.57
			7300G D2K 450	7300GD2KKG/000	114,3	4.50	8,7	0.343	3290	740	1,15	0.77
			7300G D2K 600	7300GD2KKH/000	152,4	6.00	8,7	0.343	4370	982	1,51	1.01
			7300G D2K 750	7300GD2KKL/000	190,5	7.50	8,7	0.343	5450	1225	1,87	1.26
ECOLOGICAL FRICTION ABATING THERMOPLASTIC <b>e-F.A.S.T.</b>		7300G EF 325	7300GEFKD/000	82,6	3.25	8,7	0.343	2300	517	0,84	0.57	
		7300G EF 450	7300GEFGK/000	114,3	4.50	8,7	0.343	3290	740	1,15	0.77	
		7300G EF 600	7300GEFKH/000	152,4	6.00	8,7	0.343	4370	982	1,51	1.01	
		7300G EF 750	7300GEFKL/000	190,5	7.50	8,7	0.343	5450	1225	1,87	1.26	



Standard packaging:  
Rolls of 3,048 m (10 feet)

## 8,7 mm (0.343") THICKNESS SOLID TOP

This belt offers a smooth surface to provide excellent support and minimize product tippage. Particularly suitable for glass products, small sized products and unstable containers (for example PET bottles with petaloid base).



- **Belt widths:** 228,6 mm (9") or wider in 76,2 mm (3") increments
- **Working Load (at 25°C/77°F):** 30000 N/m (2,056 lbs/ft) for **UP**, **DL2** and **e-FAST** materials
- **Belt weight:** 9,36 kg/m<sup>2</sup> (1.92 lbs/ft<sup>2</sup>) for **UP**, **DL2** and **e-FAST** materials

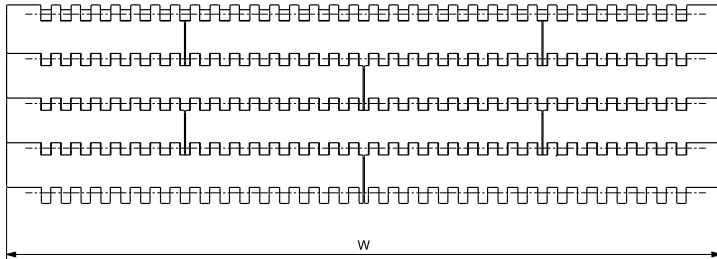
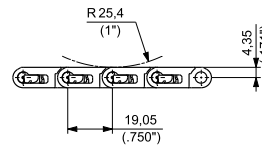

Materials see page 12



Sprockets see pages 226÷228



Applications see page 22

WIDTH W		MATERIALS			Pin
		Module			
mm	inch	<b>UP</b> ULTRA PERFORMANCE HOMOPOLYMER DELRIN®	<b>DL2</b> SPECIAL DELRIN® REINFORCED WITH KEVLAR®	<b>e-FAST</b> ECOLOGICAL FRICTION ABATING THERMOPLASTIC <span style="color:red">NEW</span>	PBT
		PART NUMBER	PART NUMBER		
228,6	9	<b>7300UP009</b>	<b>7300D2K009</b>	<b>7300EF009</b>	
304,8	12	<b>7300UP012</b>	<b>7300D2K012</b>	<b>7300EF012</b>	
381,0	15	<b>7300UP015</b>	<b>7300D2K015</b>	<b>7300EF015</b>	
457,2	18	<b>7300UP018</b>	<b>7300D2K018</b>	<b>7300EF018</b>	
533,4	21	<b>7300UP021</b>	<b>7300D2K021</b>	<b>7300EF021</b>	
609,6	24	<b>7300UP024</b>	<b>7300D2K024</b>	<b>7300EF024</b>	
685,8	27	<b>7300UP027</b>	<b>7300D2K027</b>	<b>7300EF027</b>	
762,0	30	<b>7300UP030</b>	<b>7300D2K030</b>	<b>7300EF030</b>	
838,2	33	<b>7300UP033</b>	<b>7300D2K033</b>	<b>7300EF033</b>	
914,4	36	<b>7300UP036</b>	<b>7300D2K036</b>	<b>7300EF036</b>	
990,6	39	<b>7300UP039</b>	<b>7300D2K039</b>	<b>7300EF039</b>	
1066,8	42	<b>7300UP042</b>	<b>7300D2K042</b>	<b>7300EF042</b>	
1143,0	45	<b>7300UP045</b>	<b>7300D2K045</b>	<b>7300EF045</b>	
1219,2	48	<b>7300UP048</b>	<b>7300D2K048</b>	<b>7300EF048</b>	
1295,4	51	<b>7300UP051</b>	<b>7300D2K051</b>	<b>7300EF051</b>	
1371,6	54	<b>7300UP054</b>	<b>7300D2K054</b>	<b>7300EF054</b>	
1447,8	57	<b>7300UP057</b>	<b>7300D2K057</b>	<b>7300EF057</b>	
1524,0	60	<b>7300UP060</b>	<b>7300D2K060</b>	<b>7300EF060</b>	

Belts wider than 1524 mm (60") are available in 76,2 mm (3") increments.  
To identify the Part Numbers, please substitute the last three digits of the PN with the desired width.  
Example: for a 63" wide belt (=60+3 inches) the PN for UP material is "7300UP063".  
On request belts available in 1/8" (8,5 mm) increments, starting from 9" (228,6 mm).



**Standard packaging:**  
Belts are supplied in the length requested by the customer.

### ACTIVE TRANSFER MODULES 8,7 mm (0.343") THICKNESS SOLID TOP

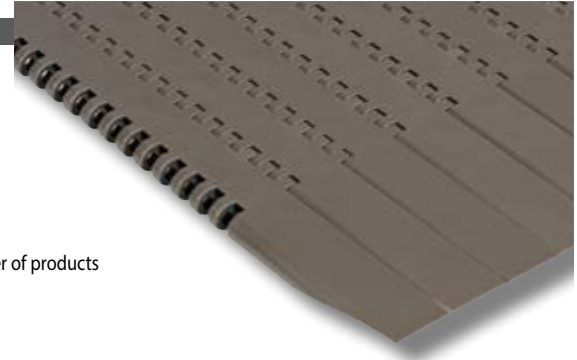

7300G ATM can be used in combination with 7300 modular belts. Active transfer modules 7300G ATM allow the transfer of products between two 90° conveyor tracks without using dead plates. The special wing shaped module profile supports the products dynamically during transfer on the take-away belts. Available left and right version.

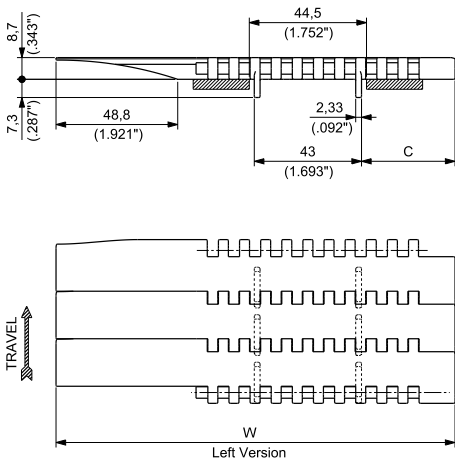

**K 4½": C = 37,5 mm (1.477")**  
**K 7½": C = 71,5 mm (2.815")**

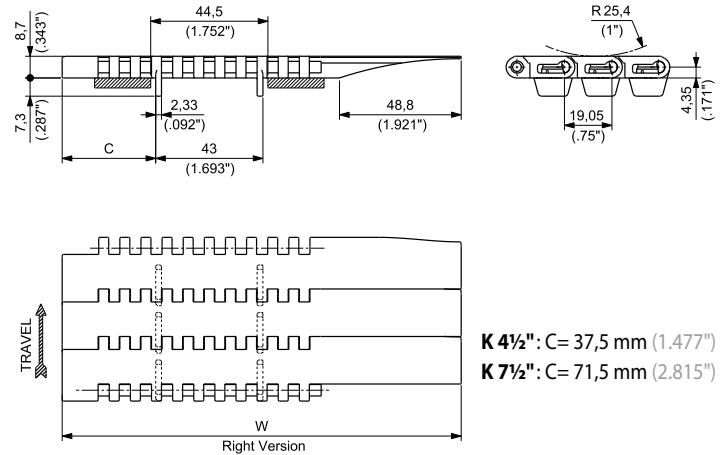

**K 4½": C = 37,5 mm (1.477")**  
**K 7½": C = 71,5 mm (2.815")**

#### 7300G ATM - Left Version

MATERIALS		ITEM DESCRIPTION	PART NUMBER	WIDTH W		PLATE THICKNESS		WORKING LOAD (25°C/77°F)		WEIGHT	
Plate	Pin			mm	inch	mm	inch	N	lbs	kg/m	lbs/ft
ULTRA PERFORMANCE HOMOPOLYMER DELRIN® <b>UP</b>		7300GATM UP 450 SX	7300GATMUP450LH	160,0	6.30	8,7	0.343	3290	740	1,28	0.86
		7300GATM UP 750 SX	7300GATMUP750LH	236,2	9.30	8,7	0.343	4370	982	1,99	1.34
SPECIAL DELRIN® REINFORCED WITH KEVLAR® <b>DK2</b>	PBT	7300GATM D2K 450 SX	7300GATMD2K450LH	160,0	6.30	8,7	0.343	3290	740	1,28	0.86
		7300GATM D2K 750 SX	7300GATMD2K750LH	236,2	9.30	8,7	0.343	4370	982	1,99	1.34
ECOLOGICAL FRICTION ABATING THERMOPLASTIC <b>e-FAST</b>	<b>NEW</b>	7300GATM EF 450 SX	7300GATMEF450LH	160,0	6.30	8,7	0.343	3290	740	1,28	0.86
		7300GATM EF 750 SX	7300GATMEF750LH	236,2	9.30	8,7	0.343	4370	982	1,99	1.34

#### 7300G ATM - Right Version

MATERIALS		ITEM DESCRIPTION	PART NUMBER	WIDTH W		PLATE THICKNESS		WORKING LOAD (25°C/77°F)		WEIGHT	
Plate	Pin			mm	inch	mm	inch	N	lbs	kg/m	lbs/ft
ULTRA PERFORMANCE HOMOPOLYMER DELRIN® <b>UP</b>		7300GATM UP 450 DX	7300GATMUP450RH	160,0	6.30	8,7	0.343	3290	740	1,28	0.86
		7300GATM UP 750 DX	7300GATMUP750RH	236,2	9.30	8,7	0.343	4370	982	1,99	1.34
SPECIAL DELRIN® REINFORCED WITH KEVLAR® <b>DK2</b>	PBT	7300GATM D2K 450 DX	7300GATMD2K450RH	160,0	6.30	8,7	0.343	3290	740	1,28	0.86
		7300GATM D2K 750 DX	7300GATMD2K750RH	236,2	9.30	8,7	0.343	4370	982	1,99	1.34
ECOLOGICAL FRICTION ABATING THERMOPLASTIC <b>e-FAST</b>	<b>NEW</b>	7300GATM EF 450 DX	7300GATMEF450RH	160,0	6.30	8,7	0.343	3290	740	1,28	0.86
		7300GATM EF 750 DX	7300GATMEF750RH	236,2	9.30	8,7	0.343	4370	982	1,99	1.34



Materials see page 12



Sprockets see pages 226+228



Applications see page 22



Standard packaging:  
Rolls of 3,048 m (10 feet)



### 8,7 mm (0.343") THICKNESS FLUSH GRID

This belt has an excellent combination of open and support areas to allow drainage of liquids and good support of the conveyed product. This belt is particularly suitable for conveying of aluminium cans.

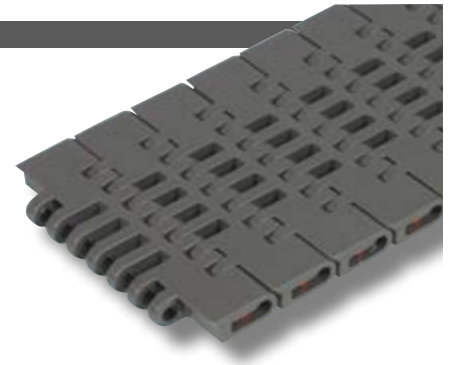

VERSION WITHOUT TRACKING GUIDE

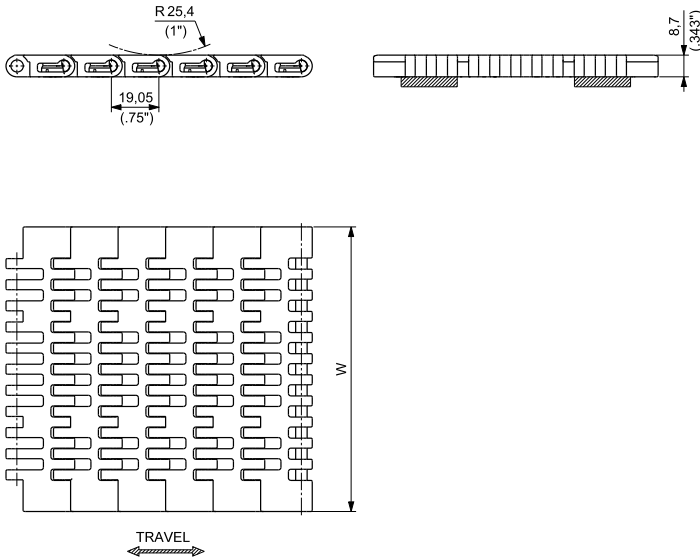

VERSION WITH TRACKING GUIDE

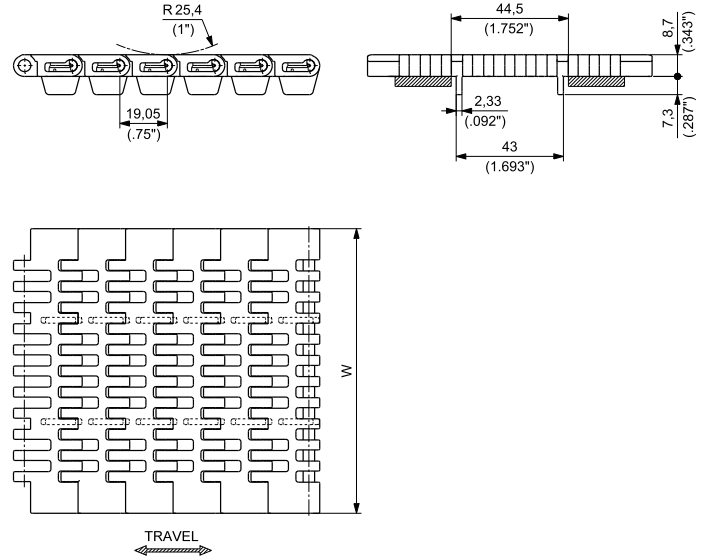

Materials see page 12



Sprockets see pages 226÷228



Applications see page 22

MATERIALS		VERSION	ITEM DESCRIPTION	PART NUMBER	WIDTH W		PLATE THICKNESS		WORKING LOAD (25°C/77°F)		WEIGHT	
Plate	Pin				mm	inch	mm	inch	N	lbs	kg/m	lbs/ft
ULTRA PERFORMANCE HOMOPOLYMER DELRIN® <b>UP</b>			7200 UP 325	7200UPKD/000	82,6	3.25	8,7	0.343	2300	517	0,80	0.54
			7200 UP 450	7200UPKG/000	114,3	4.50	8,7	0.343	3290	740	1,08	0.72
			7200 UP 600	7200UPKH/000	152,4	6.00	8,7	0.343	4370	982	1,41	0.95
			7200 UP 750	7200UPKL/000	190,5	7.50	8,7	0.343	5450	1225	1,74	1.17
SPECIAL DELRIN® REINFORCED WITH KEVLAR® <b>DK2</b>	PBT	WITHOUT TRACKING GUIDE	7200 D2K 325	7200D2KKD/000	82,6	3.25	8,7	0.343	2300	517	0,80	0.54
			7200 D2K 450	7200D2KKG/000	114,3	4.50	8,7	0.343	3290	740	1,08	0.72
			7200 D2K 600	7200D2KKH/000	152,4	6.00	8,7	0.343	4370	982	1,41	0.95
			7200 D2K 750	7200D2KKL/000	190,5	7.50	8,7	0.343	5450	1225	1,74	1.17
<b>NEW</b> ECOLOGICAL FRICTION ABATING THERMOPLASTIC <b>e-FAST</b>			7200 EF 325	7200EFKD/000	82,6	3.25	8,7	0.343	2300	517	0,80	0.54
			7200 EF 450	7200EFKG/000	114,3	4.50	8,7	0.343	3290	740	1,08	0.72
			7200 EF 600	7200EFKH/000	152,4	6.00	8,7	0.343	4370	982	1,41	0.95
			7200 EF 750	7200EFKL/000	190,5	7.50	8,7	0.343	5450	1225	1,74	1.17
ULTRA PERFORMANCE HOMOPOLYMER DELRIN® <b>UP</b>			7200G UP 325	7200GUPKD/000	82,6	3.25	8,7	0.343	2300	517	0,80	0.54
			7200G UP 450	7200GUPKG/000	114,3	4.50	8,7	0.343	3290	740	1,08	0.72
			7200G UP 600	7200GUPKH/000	152,4	6.00	8,7	0.343	4370	982	1,41	0.95
			7200G UP 750	7200GUPKL/000	190,5	7.50	8,7	0.343	5450	1225	1,74	1.17
SPECIAL DELRIN® REINFORCED WITH KEVLAR® <b>DK2</b>	PBT	WITH TRACKING GUIDE	7200G D2K 325	7200GD2KKD/000	82,6	3.25	8,7	0.343	2300	517	0,80	0.54
			7200G D2K 450	7200GD2KKG/000	114,3	4.50	8,7	0.343	3290	740	1,08	0.72
			7200G D2K 600	7200GD2KKH/000	152,4	6.00	8,7	0.343	4370	982	1,41	0.95
			7200G D2K 750	7200GD2KKL/000	190,5	7.50	8,7	0.343	5450	1225	1,74	1.17
<b>NEW</b> ECOLOGICAL FRICTION ABATING THERMOPLASTIC <b>e-FAST</b>			7200G EF 325	7200GEFKD/000	82,6	3.25	8,7	0.343	2300	517	0,80	0.54
			7200G EF 450	7200GEFKG/000	114,3	4.50	8,7	0.343	3290	740	1,08	0.72
			7200G EF 600	7200GEFKH/000	152,4	6.00	8,7	0.343	4370	982	1,41	0.95
			7200G EF 750	7200GEFKL/000	190,5	7.50	8,7	0.343	5450	1225	1,74	1.17



Standard packaging:  
Rolls of 3,048 m (10 feet)

## 8,7 mm (0.343") THICKNESS FLUSH GRID

This belt has an excellent combination of open and support areas to allow drainage of liquids and good support of the conveyed product. This belt is particularly suitable for conveying of aluminium cans.

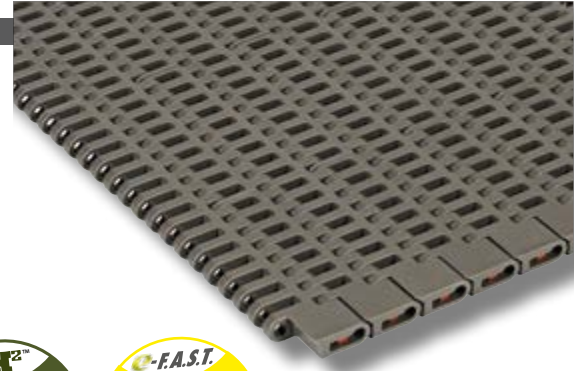

- **Belt widths:** 228,6 mm (9") or wider in 76,2 mm (3") increments
- **Working Load (at 25°C/77°F):** 30000 N/m (2,056 lbs/ft) for **UP**, **DK<sup>2</sup>** and **e-F.A.S.T.** materials
- **Belt weight:** 8,46 kg/m<sup>2</sup> (1.73 lbs/ft<sup>2</sup>) for **UP**, **DK<sup>2</sup>** and **e-F.A.S.T.** materials

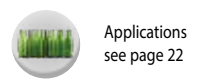
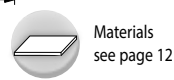
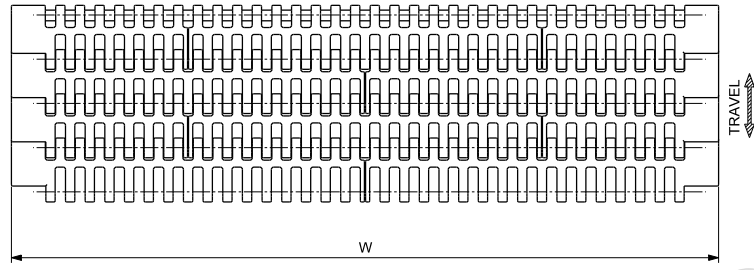
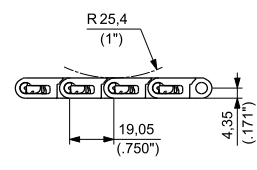
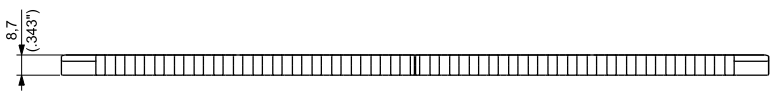

WIDTH W		MATERIALS			Pin
		Module			
		<b>UP</b> ULTRA PERFORMANCE HOMOPOLYMER DELRIN®	<b>DK<sup>2</sup></b> SPECIAL DELRIN® REINFORCED WITH KEVLAR®	<b>e-F.A.S.T.</b> ECOLOGICAL FRICTION ABATING THERMOPLASTIC	
mm	inch	PART NUMBER	PART NUMBER		
228,6	9	<b>7200UP009</b>	<b>7200D2K009</b>	<b>7200EF009</b>	PBT
304,8	12	<b>7200UP012</b>	<b>7200D2K012</b>	<b>7200EF012</b>	
381,0	15	<b>7200UP015</b>	<b>7200D2K015</b>	<b>7200EF015</b>	
457,2	18	<b>7200UP018</b>	<b>7200D2K018</b>	<b>7200EF018</b>	
533,4	21	<b>7200UP021</b>	<b>7200D2K021</b>	<b>7200EF021</b>	
609,6	24	<b>7200UP024</b>	<b>7200D2K024</b>	<b>7200EF024</b>	
685,8	27	<b>7200UP027</b>	<b>7200D2K027</b>	<b>7200EF027</b>	
762,0	30	<b>7200UP030</b>	<b>7200D2K030</b>	<b>7200EF030</b>	
838,2	33	<b>7200UP033</b>	<b>7200D2K033</b>	<b>7200EF033</b>	
914,4	36	<b>7200UP036</b>	<b>7200D2K036</b>	<b>7200EF036</b>	
990,6	39	<b>7200UP039</b>	<b>7200D2K039</b>	<b>7200EF039</b>	
1066,8	42	<b>7200UP042</b>	<b>7200D2K042</b>	<b>7200EF042</b>	
1143,0	45	<b>7200UP045</b>	<b>7200D2K045</b>	<b>7200EF045</b>	
1219,2	48	<b>7200UP048</b>	<b>7200D2K048</b>	<b>7200EF048</b>	
1295,4	51	<b>7200UP051</b>	<b>7200D2K051</b>	<b>7200EF051</b>	
1371,6	54	<b>7200UP054</b>	<b>7200D2K054</b>	<b>7200EF054</b>	
1447,8	57	<b>7200UP057</b>	<b>7200D2K057</b>	<b>7200EF057</b>	
1524,0	60	<b>7200UP060</b>	<b>7200D2K060</b>	<b>7200EF060</b>	

Belts wider than 1524 mm (60") are available in 76,2 mm (3") increments.  
To identify the Part Numbers, please substitute the last three digits of the PN with the desired width.  
Example: for a 63" wide belt (=60+3 inches) the PN for UP material is "7200UP063".  
On request belts available in 1/8" (8,5 mm) increments, starting from 9" (228,6 mm).



**Standard packaging:**  
Belts are supplied in the length requested by the customer.

## SUITABLE FOR CHAINS:

- 7200
- 7300

MATERIALS	
SPROCKETS:	<b>PGF</b> REINFORCED POLYAMIDE
SCREW:	<b>SS</b> STAINLESS STEEL
NUTS:	<b>S+ZN</b> ZINC PLATED STEEL



## 24T & 25T SPROCKETS

(for 27T see next page)

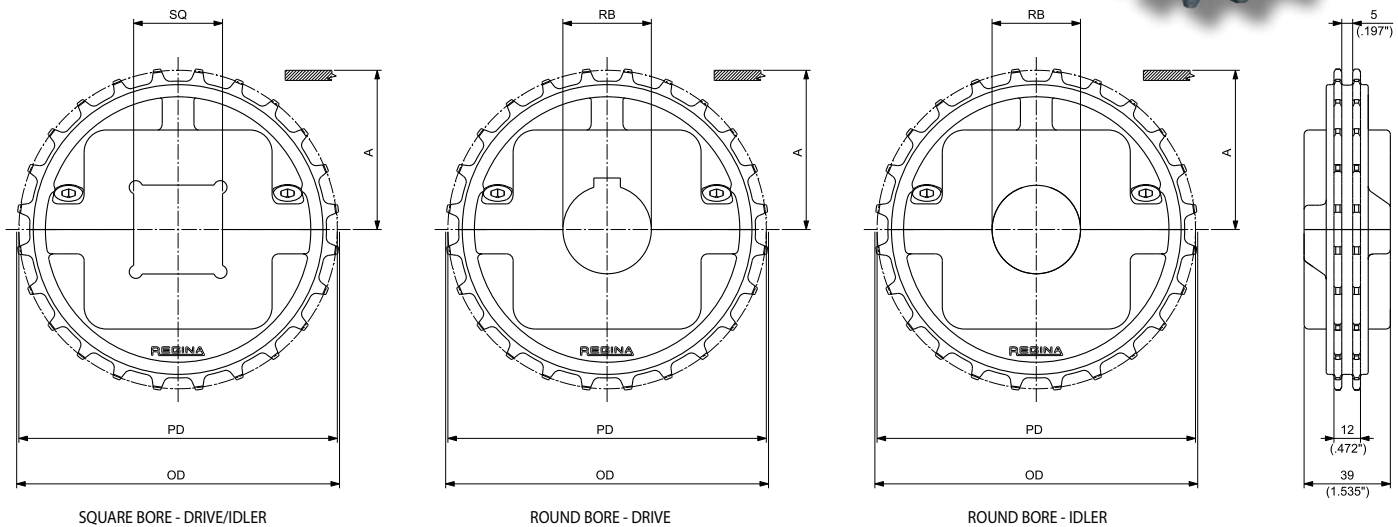

## MOULDED SPLIT DRIVE AND IDLER SPROCKETS

N. TEETH	PITCH DIAMETER PD		OUTSIDE DIAMETER OD		WEAR STRIP POSITIONING A		BORE SIZE*		PART NUMBER			WEIGHT		
	mm	inch	mm	inch	mm	inch	mm	inch**	SQUARE BORE SQ DRIVE/IDLER	ROUND BORE RB DRIVE	ROUND BORE RB IDLER	Kg	lbs	
24	145,95	5.746	146,00	5.748	68,60	2.701				MPBST73002430	MPBSF73002430	0,41	0.91	
										MPBST73002435	MPBSF73002435	0,41	0.90	
									MPBSQ73002440	MPBST73002440	MPBSF73002440	0,40	0.88	
										MPBST73002445	MPBSF73002445	0,39	0.86	
									MPBSQ73002450	MPBST73002450	MPBSF73002450	0,38	0.83	
										MPBST73002460	MPBSF73002460	0,35	0.78	
									MPBSQ730024254	MPBST730024254	MPBSF730024254	0,42	0.93	
									1 3/16	MPBST730024301	MPBSF730024301	0,41	0.91	
									1 1/4	MPBST730024317	MPBSF730024317	0,41	0.91	
									1 7/16	MPBST730024365	MPBSF730024365	0,40	0.89	
									1 1/2	MPBSQ730024381	MPBST730024381	MPBSF730024381	0,40	0.88
									2	MPBSQ730024508	MPBST730024508	MPBSF730024508	0,38	0.83
									2 1/2	MPBSQ730024635	MPBST730024635	MPBSF730024635	0,34	0.76
									25	152,99	6.023	152,00	5.984	71,70
	MPBST73002535	MPBSF73002535	0,42	0.93										
MPBSQ73002540	MPBST73002540	MPBSF73002540	0,41	0.91										
	MPBST73002545	MPBSF73002545	0,40	0.89										
MPBSQ73002550	MPBST73002550	MPBSF73002550	0,39	0.86										
	MPBST73002560	MPBSF73002560	0,37	0.81										
MPBSQ730025254	MPBST730025254	MPBSF730025254	0,43	0.96										
1 3/16	MPBST730025301	MPBSF730025301	0,43	0.94										
1 1/4	MPBST730025317	MPBSF730025317	0,43	0.94										
1 7/16	MPBST730025365	MPBSF730025365	0,42	0.92										
1 1/2	MPBSQ730025381	MPBST730025381	MPBSF730025381	0,42	0.92									
2	MPBSQ730025508	MPBST730025508	MPBSF730025508	0,39	0.86									
2 1/2	MPBSQ730025635	MPBST730025635	MPBSF730025635	0,36	0.79									

\*In case of round bore, diameter is indicated. In case of square bore, side of the square is indicated.

\*\* Imperial round bore drive sprockets are supplied with setscrew. Metric round bore drive sprockets are supplied without setscrew.

## SUITABLE FOR CHAINS:

- 7200
- 7300

MATERIALS	
SPROCKETS:	<b>PGF</b> REINFORCED POLYAMIDE
SCREW:	<b>SS</b> STAINLESS STEEL
NUTS:	<b>S+ZN</b> ZINC PLATED STEEL



## 27T SPROCKET

(for 24T & 25T see previous page)

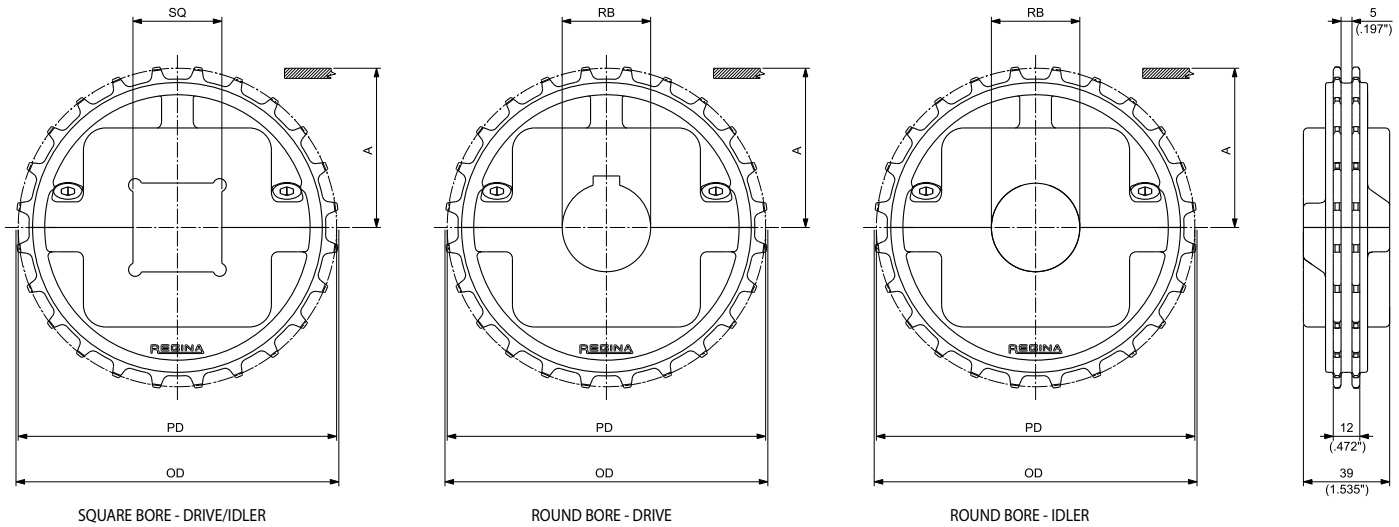

SQUARE BORE - DRIVE/IDLER

ROUND BORE - DRIVE

ROUND BORE - IDLER



**MOULDED SOLID IDLER WHEELS**  
SEE PAGE 124



**MOULDED SPLIT IDLER WHEELS**  
SEE PAGE 193



**MACHINED SPLIT IDLER WHEELS**  
SEE PAGE 126

## MOULDED SPLIT DRIVE AND IDLER SPROCKETS

N. TEETH	PITCH DIAMETER PD		OUTSIDE DIAMETER OD		WEAR STRIP POSITIONING A		BORE SIZE*		PART NUMBER			WEIGHT	
	mm	inch	mm	inch	mm	inch	mm	inch**	SQUARE BORE SQ DRIVE/IDLER	ROUND BORE RB DRIVE	ROUND BORE RB IDLER	Kg	lbs
										MPBST73002730	MPBSF73002730	0,46	1.01
										MPBST73002735	MPBSF73002735	0,45	0.99
									MPBSQ73002740	MPBST73002740	MPBSF73002740	0,44	0.97
										MPBST73002745	MPBSF73002745	0,43	0.95
									MPBSQ73002750	MPBST73002750	MPBSF73002750	0,42	0.93
27	164,09	6.460	164,20	6.465	77,70	3.059				MPBST73002760	MPBSF73002760	0,40	0.87
										MPBSQ730027254	MPBSF730027254	0,46	1.02
										MPBST730027301	MPBSF730027301	0,46	1.01
										MPBST730027317	MPBSF730027317	0,46	1.01
										MPBST730027365	MPBSF730027365	0,45	0.99
									MPBSQ730027381	MPBST730027381	MPBSF730027381	0,45	0.98
										MPBSQ730027508	MPBST730027508	0,42	0.93
										MPBSQ730027635	MPBST730027635	0,39	0.85

\*In case of round bore, diameter is indicated. In case of square bore, side of the square is indicated.

\*\* Imperial round bore drive sprockets are supplied with setscrew. Metric round bore drive sprockets are supplied without setscrew.

## SUITABLE FOR CHAINS:

- 7200
- 7300

### MATERIALS

SPROCKETS:	<b>PA</b>	POLYAMIDE
SCREWS:	<b>SS</b>	STAINLESS STEEL
NUTS:	<b>B</b>	BRASS

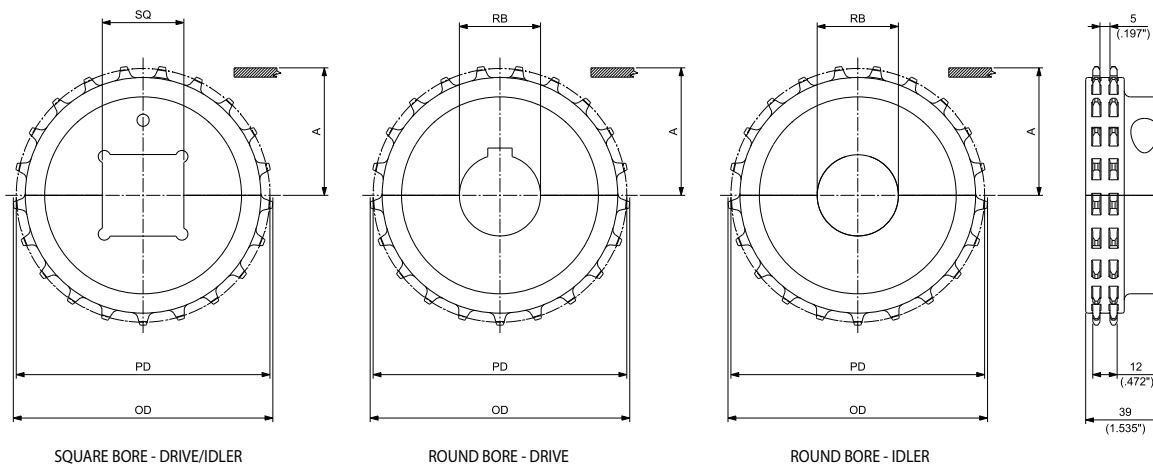

## MACHINED SPLIT DRIVE AND IDLER SPROCKETS

N. TEETH	PITCH DIAMETER PD		OUTSIDE DIAMETER OD		WEAR STRIP POSITIONING A		BORE SIZE*		PART NUMBER			WEIGHT	
	mm	inch	mm	inch	mm	inch	mm	inch**	SQUARE BORE SQ	ROUND BORE RB		Kg	lbs
									DRIVE/IDLER	DRIVE	IDLER		
17	103,67	4.081	103,60	4.079	47,50	1.870	25			<b>MPBAST73001725</b>	<b>MPBASQ73001725</b>	0,25	0.54
							30			<b>MPBAST73001730</b>	<b>MPBASQ73001730</b>	0,24	0.52
							35			<b>MPBAST73001735</b>	<b>MPBASQ73001735</b>	0,23	0.50
							40			<b>MPBAST73001740</b>	<b>MPBASQ73001740</b>	0,21	0.47
							1	<b>MPBASQ730017254</b>	<b>MPBAST730017254</b>	<b>MPBASQ730017254</b>	0,25	0.54	
							1 3/16			<b>MPBAST730017301</b>	<b>MPBASQ730017301</b>	0,24	0.52
							1 1/4			<b>MPBAST730017317</b>	<b>MPBASQ730017317</b>	0,23	0.52
							1 3/8			<b>MPBAST730017349</b>	<b>MPBASQ730017349</b>	0,23	0.50
							1 7/16			<b>MPBAST730017365</b>	<b>MPBASQ730017365</b>	0,22	0.49
							1 1/2	<b>MPBASQ101017381</b>	<b>MPBAST730017381</b>	<b>MPBASQ101017381</b>	0,22	0.48	
21	127,82	5.032	127,90	5.035	59,60	2.346	25			<b>MPBAST73002125</b>	<b>MPBASQ73002125</b>	0,42	0.92
							30			<b>MPBAST73002130</b>	<b>MPBASQ73002130</b>	0,41	0.90
							35			<b>MPBAST73002135</b>	<b>MPBASQ73002135</b>	0,40	0.88
							40			<b>MPBAST73002140</b>	<b>MPBASQ73002140</b>	0,39	0.85
							45			<b>MPBAST73002145</b>	<b>MPBASQ73002145</b>	0,37	0.82
							50			<b>MPBAST73002150</b>	<b>MPBASQ73002150</b>	0,35	0.78
							60			<b>MPBAST73002160</b>	<b>MPBASQ73002160</b>	0,32	0.69
							1	<b>MPBASQ730021254</b>	<b>MPBAST730021254</b>	<b>MPBASQ730021254</b>	0,42	0.92	
							1 3/16			<b>MPBAST730021301</b>	<b>MPBASQ730021301</b>	0,41	0.90
							1 1/4			<b>MPBAST730021317</b>	<b>MPBASQ730021317</b>	0,41	0.90
							1 3/8			<b>MPBAST730021349</b>	<b>MPBASQ730021349</b>	0,40	0.88
							1 7/16			<b>MPBAST730021365</b>	<b>MPBASQ730021365</b>	0,39	0.87
							1 1/2	<b>MPBASQ730021381</b>	<b>MPBAST730021381</b>	<b>MPBASQ730021381</b>	0,39	0.86	
2	<b>MPBASQ730021508</b>	<b>MPBAST730021508</b>	<b>MPBASQ730021508</b>	0,35	0.77								

\*In case of round bore, diameter is indicated. In case of square bore, side of the square is indicated.

\*\*Imperial round bore drive sprockets are supplied with setscrew. Metric round bore drive sprockets are supplied without setscrew.





PERFORMANCE IN MOTION

# Matveyor<sup>®</sup>

## 1" Pitch Heavy Duty Belts and Chains





## INDUSTRIES AND APPLICATIONS

Suitable for handling loose and packaged products, such as glass bottles, aluminium & steel cans, in heavy duty applications

### INDUSTRIES

Bottling and canning  
 Container manufacturing  
 (in particular glass bottles)  
 Paper/cardboard

### APPLICATIONS

Depalletizer  
 Pressureless Inliners and Combiners  
 Single lane & mass conveyors  
 Accumulation tables  
 Case conveyors  
 Palletizers



## FEATURES

- Strong hinge design ensure high mechanical strength for the most demanding applications.
- Round design edge and no gap between hinges allow a superior product handling in linear and side transfer of the products.
- Large and close bottom sliding surface with strong edges allow:
  - Higher belt wear resistance thanks to the less specific pressure between belt and wear strips
  - Maximum resistance against broken debris present on the line
- The belts can be used on conveyors side by side with Magnetic or TAB sideflexing chains 793 series allowing a smooth products transfer between straight running and sideflexing conveyors.
- Availability of LBP version (LBP USPM and LBP XSPM series), equipped with superior rotation capability rollers, to safely handle packaged products in long center to center accumulation conveyors.
- Rubberized belts available (HF USPM series) displaying maximum and inform rubberized area allowing outstanding gripping capacity on the conveyed products.



### 12,7 mm (0.5") THICKNESS SOLID TOP

The extremely good flatness, manufacturing accuracy and low coefficient of friction make the side transfer of the products very easy. Completely closed surface, no gap between the modules, even when engaging on the sprockets. Particularly suitable for glass products, small sized products and unstable containers (for example PET bottles with petaloid base)

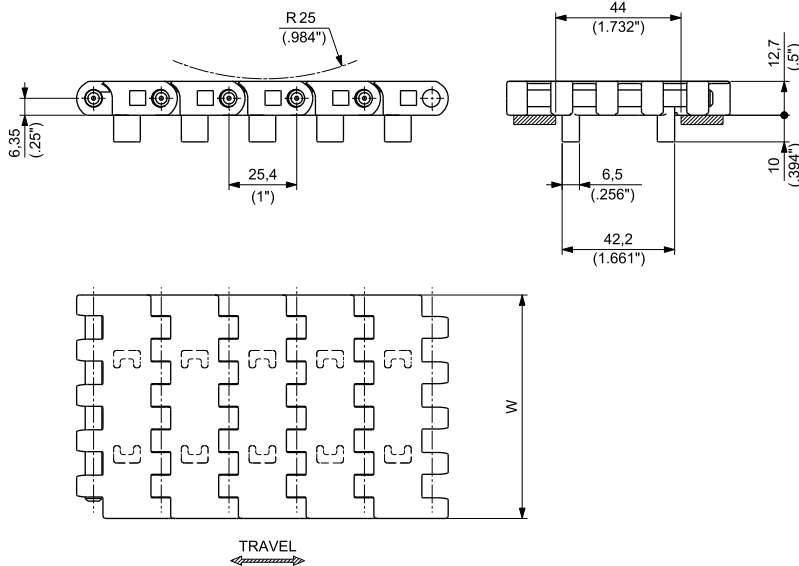

Materials  
see page 12



Sprockets  
see pages 241+243



Applications  
see page 22

MATERIALS		ITEM DESCRIPTION	PART NUMBER	WIDTH W		PLATE THICKNESS		WORKING LOAD (25°C/77°F)		WEIGHT	
Plate	Pin			mm	inch	mm	inch	N	lbs	kg/m	lbs/ft
ULTRA PERFORMANCE HOMOPOLYMER DELRIN® <b>UP</b>		USPMG UP K 83,8	USPMGUPKRA/000	83,8	3.30	12,7	0.50	2975	670	1,24	0.83
SPECIAL DELRIN® REINFORCED WITH KEVLAR® <b>DK2</b>	PBT	USPMG D2K K 83,8	USPMGD2KRA/000	83,8	3.30	12,7	0.50	2975	670	1,24	0.68
ABRASION RESISTANT POLYAMIDE* <b>AR</b>		USPMG AR K 83,8	USPMGARKRA/000	83,8	3.30	12,7	0.50	2975	670	1,19	0.80

\*Actual width is larger than the nominal width.



Standard packaging:  
Rolls of 3,048 m (10 feet)

### 12,7 mm (0.5") THICKNESS SOLID TOP

Extremely good flatness, manufacturing accuracy and low coefficient of friction make the side transfer of the products very easy.  
Completely closed surface, no gap between the modules, even when engaging on the sprockets. Particular suitable for glass products, small sized products and unstable containers (for example PET bottles with petaloid base)

- **Belt widths:** 85 mm (3.34") or wider in 85 mm (3.34") increments
- **Working Load (at 25°C/77°F):** 35000 N/m (2400 lbs/ft) for **UP**, **DK2** and **AR** materials
- **Belt weight:** 14,11 kg/m<sup>2</sup> (2.89 lbs/ft<sup>2</sup>) for **UP** and **DK2** materials  
13,59 kg/m<sup>2</sup> (2.78 lbs/ft<sup>2</sup>) for **AR** material



VERSION WITHOUT TRACKING GUIDE

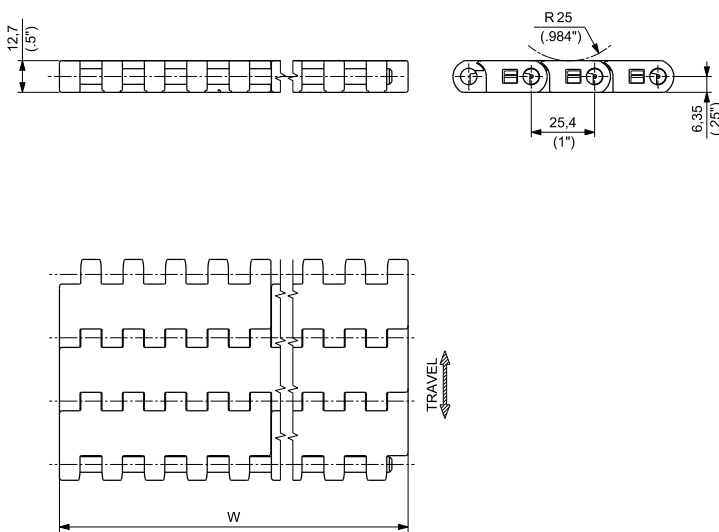

VERSION WITH TRACKING GUIDE

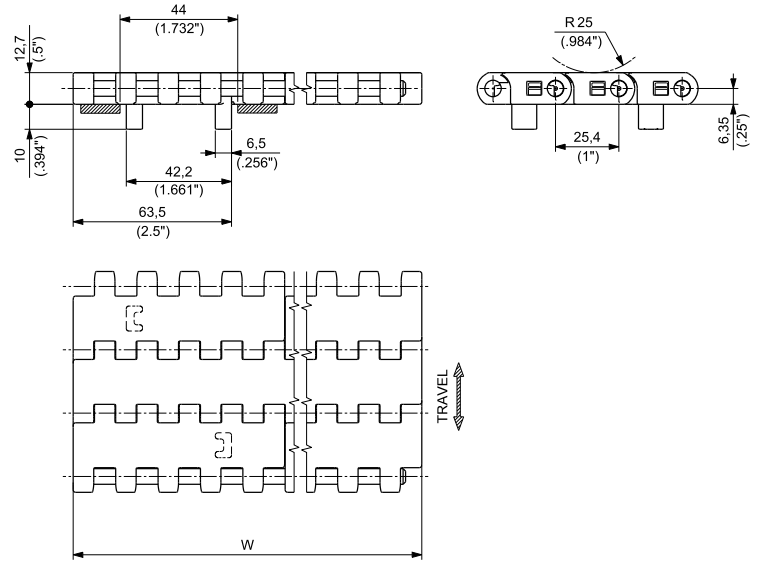

NOTE: The belt is also available with single tracking guide at both belt sides. Please contact REGINA customer service for further information.



Materials see page 12



Sprockets see pages 241-243



Applications see page 22

WIDTH W	MATERIALS							Pin
	Module						PBT	
	UP ULTRA PERFORMANCE HOMOPOLYMER DELRIN®		DK2 SPECIAL DELRIN® REINFORCED WITH KEVLAR®		AR ABRASION RESISTANT POLYAMIDE*			
	PART NUMBER		PART NUMBER		PART NUMBER			
mm	inch	WITHOUT TRACKING GUIDE	WITH TRACKING GUIDE	WITHOUT TRACKING GUIDE	WITH TRACKING GUIDE	WITHOUT TRACKING GUIDE	WITH TRACKING GUIDE	
85	3.34	USPMUP0085	USPMGUP0085	USPMD2K0085	USPMGD2K0085	USPMAR0085	USPMGAR0085	
170	6.69	USPMUP0170	USPMG1UP0170	USPMD2K0170	USPMG1D2K0170	USPMAR0170	USPMG1AR0170	
255	10.04	USPMUP0255	USPMG1UP0255	USPMD2K0255	USPMG1D2K0255	USPMAR0255	USPMG1AR0255	
340	13.39	USPMUP0340	USPMG1UP0340	USPMD2K0340	USPMG1D2K0340	USPMAR0340	USPMG1AR0340	
425	16.73	USPMUP0425	USPMG1UP0425	USPMD2K0425	USPMG1D2K0425	USPMAR0425	USPMG1AR0425	
510	20.08	USPMUP0510	USPMG1UP0510	USPMD2K0510	USPMG1D2K0510	USPMAR0510	USPMG1AR0510	
595	23.43	USPMUP0595	USPMG1UP0595	USPMD2K0595	USPMG1D2K0595	USPMAR0595	USPMG1AR0595	
680	26.77	USPMUP0680	USPMG1UP0680	USPMD2K0680	USPMG1D2K0680	USPMAR0680	USPMG1AR0680	
765	30.12	USPMUP0765	USPMG1UP0765	USPMD2K0765	USPMG1D2K0765	USPMAR0765	USPMG1AR0765	
850	33.46	USPMUP0850	USPMG1UP0850	USPMD2K0850	USPMG1D2K0850	USPMAR0850	USPMG1AR0850	
935	36.81	USPMUP0935	USPMG1UP0935	USPMD2K0935	USPMG1D2K0935	USPMAR0935	USPMG1AR0935	
1020	40.16	USPMUP1020	USPMG1UP1020	USPMD2K1020	USPMG1D2K1020	USPMAR1020	USPMG1AR1020	

Belts wider than 1020 mm (40.16") are available in 85 mm (3.35") increments.  
To identify the Part Numbers, please substitute the last four digits of the PN with the desired width.  
Example: for a 1105 mm wide belt (=1020+85 mm) without guide, the PN for UP material is "USPMUP1105".  
\*Actual width is larger than the nominal width.



Standard packaging:  
Belt widths ≤ 680 mm (26.77") are supplied in rolls of 3,048 m (10 ft) each.  
Belt widths ≥ 765 mm (30.12") are supplied in the length requested by the customer.

### ACTIVE TRANSFER MODULES 12,7 mm (0.5") THICKNESS SOLID TOP

Extremely good flatness, manufacturing accuracy and low coefficient of friction make the side transfer of the products very easy. Completely closed surface, no gap between the modules, even when engaging on the sprockets. Particular suitable for glass products, small sized products and unstable containers (for example PET bottles with petaloid base)

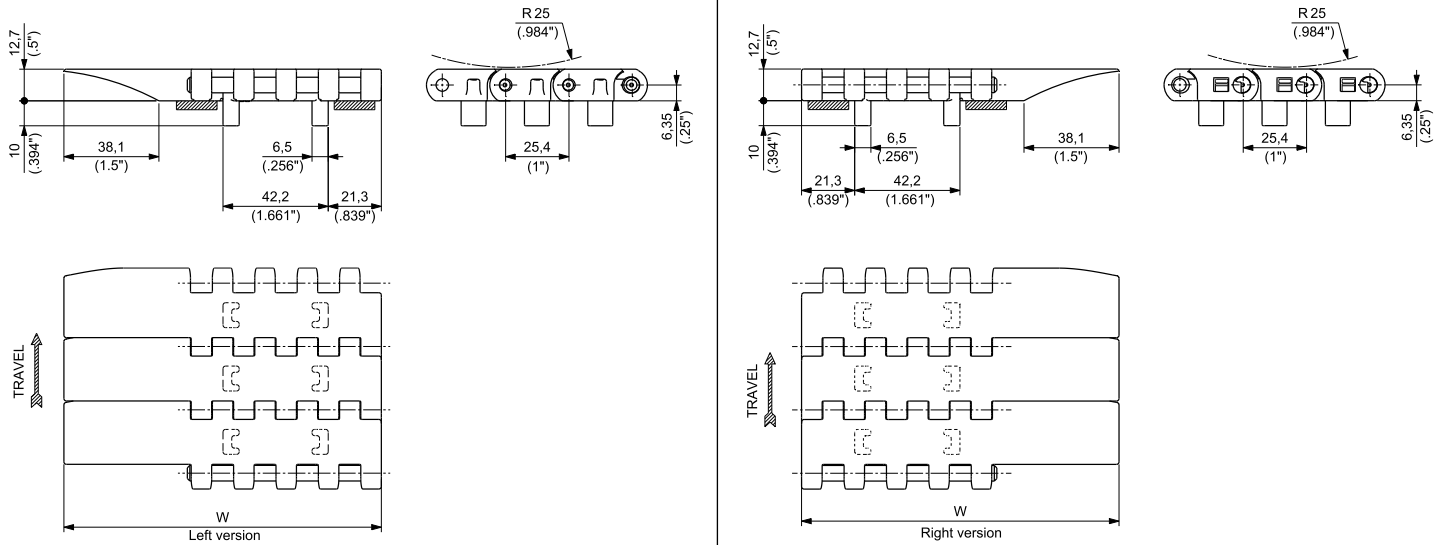
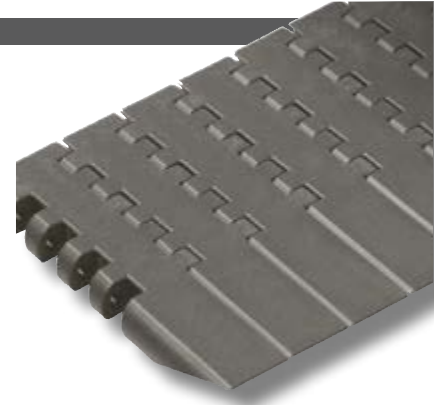

#### USPMG ATM - Left Version

MATERIALS		ITEM DESCRIPTION	PART NUMBER	WIDTH W		PLATE THICKNESS		WORKING LOAD (25°C/77°F)		WEIGHT	
Plate	Pin			mm	inch	mm	inch	N	lbs	kg/m	lbs/ft
ULTRA PERFORMANCE HOMOPOLYMER DELRIN® <b>UP</b>		USPMGATM UP 0085 SX	USPMGATMUP085S	127,5	5.02	12,7	0.5	2975	669	1,55	1.04
SPECIAL DELRIN® REINFORCED WITH KEVLAR® <b>D2K</b>	PBT	USPMGATM D2K 0085 SX	USPMGATMD2K085S	127,5	5.02	12,7	0.5	2975	669	1,55	1.04
ABRASION RESISTANT POLYAMIDE* <b>AR</b>		USPMGATM AR 0085 SX	USPMGATMAR085S	127,5	5.02	12,7	0.5	2975	669	1,50	1.01



Materials see page 12



Sprockets see pages 241+243



Applications see page 22

#### USPMG ATM - Right Version

MATERIALS		ITEM DESCRIPTION	PART NUMBER	WIDTH W		PLATE THICKNESS		WORKING LOAD (25°C/77°F)		WEIGHT	
Plate	Pin			mm	inch	mm	inch	N	lbs	kg/m	lbs/ft
ULTRA PERFORMANCE HOMOPOLYMER DELRIN® <b>UP</b>		USPMGATM UP 0085 DX	USPMGATMUP085D	127,5	5.02	12,7	0.5	2975	669	1,55	1.04
SPECIAL DELRIN® REINFORCED WITH KEVLAR® <b>D2K</b>	PBT	USPMGATM D2K 0085 DX	USPMGATMD2K085D	127,5	5.02	12,7	0.5	2975	669	1,55	1.04
ABRASION RESISTANT POLYAMIDE* <b>AR</b>		USPMGATM AR 0085 DX	USPMGATMAR085D	127,5	5.02	12,7	0.5	2975	669	1,50	1.01

\*Actual width is larger than the nominal width.



Standard packaging:  
Rolls of 3,048 m (10 feet)



### 12,7 mm (0.5") THICKNESS RUBBERIZED SURFACE - FULL COVER

HF USPM belts are an ideal solution for heavy duty inclines, declines and package handling (acceleration, deceleration and rotation).

- **Belt widths:** 85 mm (3.346") or wider in 85 mm (3.346") increments
- **Working Load (at 25°C/77°F):** 35000 N/m (2,400 lbs/ft) for **ULF** material  
18100 N/m (1,240 lbs/ft) for **PP** material
- **Belt weight:** 14,84 kg/m<sup>2</sup> (3.04 lbs/ft<sup>2</sup>) for **ULF** material  
10,38 kg/m<sup>2</sup> (2.13 lbs/ft<sup>2</sup>) for **PP** material

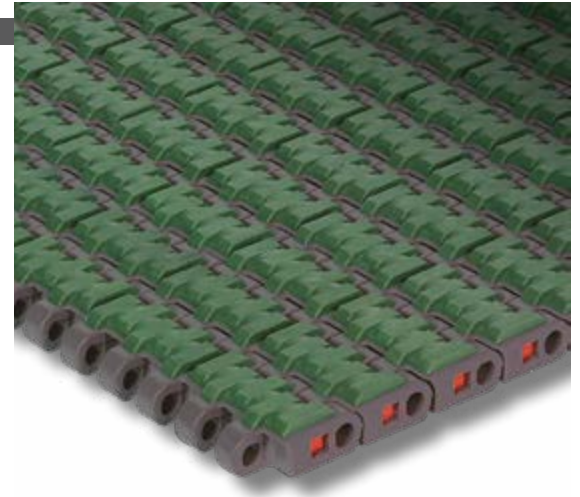

VERSION WITHOUT TRACKING GUIDE

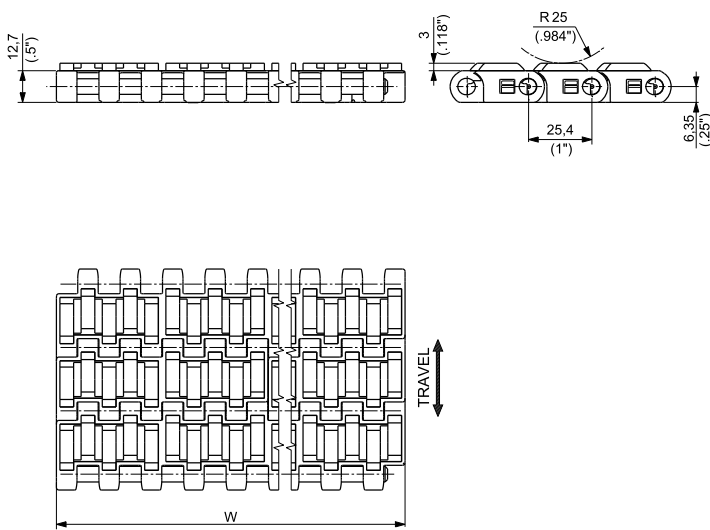

VERSION WITH TRACKING GUIDE

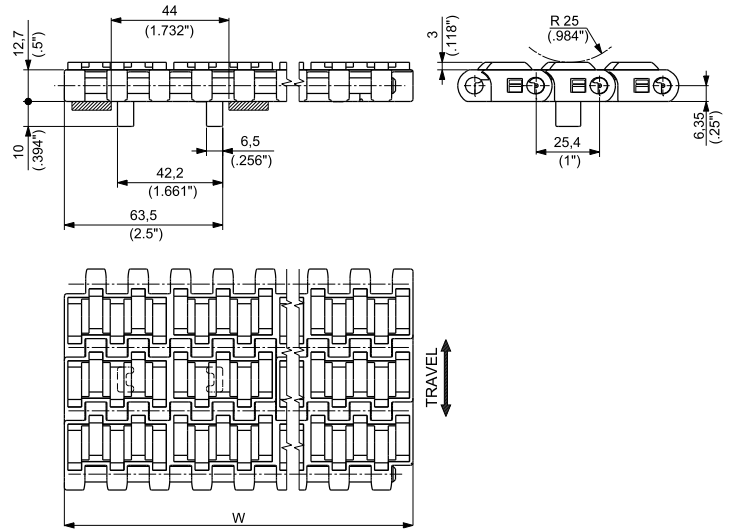

Matveyor



Materials see page 12



Sprockets see pages 241÷243



Applications see page 22

WIDTH W		MATERIALS				Rubber	Pin
		Module		ULF	PP		
		PART NUMBER					
		WITHOUT TRACKING GUIDE	WITH TRACKING GUIDE				
mm	inche	WITHOUT TRACKING GUIDE	WITH TRACKING GUIDE	WITHOUT TRACKING GUIDE	WITH TRACKING GUIDE	THERMOPLASTIC <b>TPE</b> Hardness: 55 ShA for ULF material 50 ShA for PP material	POM for ULF material PBT for PP material
85	3.35	<b>HFUMULF0085</b>	<b>HFUMGULF0085</b>	<b>HFUMPP0085</b>	<b>HFUMGPP0085</b>		
170	6.69	<b>HFUMULF0170</b>	<b>HFUMG1ULF0170</b>	<b>HFUMPP0170</b>	<b>HFUMG1PP0170</b>		
255	10.04	<b>HFUMULF0255</b>	<b>HFUMG1ULF0255</b>	<b>HFUMPP0255</b>	<b>HFUMG1PP0255</b>		
340	13.39	<b>HFUMULF0340</b>	<b>HFUMG1ULF0340</b>	<b>HFUMPP0340</b>	<b>HFUMG1PP0340</b>		
425	16.73	<b>HFUMULF0425</b>	<b>HFUMG1ULF0425</b>	<b>HFUMPP0425</b>	<b>HFUMG1PP0425</b>		
510	20.08	<b>HFUMULF0510</b>	<b>HFUMG1ULF0510</b>	<b>HFUMPP0510</b>	<b>HFUMG1PP0510</b>		
595	23.43	<b>HFUMULF0595</b>	<b>HFUMG1ULF0595</b>	<b>HFUMPP0595</b>	<b>HFUMG1PP0595</b>		
680	26.77	<b>HFUMULF0680</b>	<b>HFUMG1ULF0680</b>	<b>HFUMPP0680</b>	<b>HFUMG1PP0680</b>		
765	30.12	<b>HFUMULF0765</b>	<b>HFUMG1ULF0765</b>	<b>HFUMPP0765</b>	<b>HFUMG1PP0765</b>		
850	33.46	<b>HFUMULF0850</b>	<b>HFUMG1ULF0850</b>	<b>HFUMPP0850</b>	<b>HFUMG1PP0850</b>		
935	36.81	<b>HFUMULF0935</b>	<b>HFUMG1ULF0935</b>	<b>HFUMPP0935</b>	<b>HFUMG1PP0935</b>		
1020	40.16	<b>HFUMULF1020</b>	<b>HFUMG1ULF1020</b>	<b>HFUMPP1020</b>	<b>HFUMG1PP1020</b>		

Belts wider than 1020 mm (40.16") are available in 85 mm (3.35") increments.

To identify the Part Numbers, please substitute the last four digits of the PN with the desired width.

Example: for a 1105 mm wide belt (=1020+85 mm) without guide, the PN for ULF material is "HFUMULF1105".

\*Actual width is larger than the nominal width.



Standard packaging:

Belt widths ≤ 425 mm (16.73") are supplied in rolls of 1,524 m (5 ft) each.

Belt widths ≥ 510 mm (20.08") are supplied in the length requested by the customer.

### 12,7 mm (0.5") THICKNESS RUBBERIZED SURFACE - SIDE INDENT

HFS USPM belts are an ideal solution for heavy duty inclines, declines and package handling (acceleration, deceleration and rotation).

- **Belt widths:** 255 mm (10.04") or wider in 85 mm (3.35") increments
- **Working Load (at 25°C/77°F):** 35000 N/m (2,400 lbs/ft) for **ULF** material  
18100 N/m (1,240 lbs/ft) for **PP** material
- **Belt weight:** 14,71 kg/m<sup>2</sup> (3.01 lbs/ft<sup>2</sup>) for **ULF** material  
10,38 kg/m<sup>2</sup> (2.13 lbs/ft<sup>2</sup>) for **PP** material

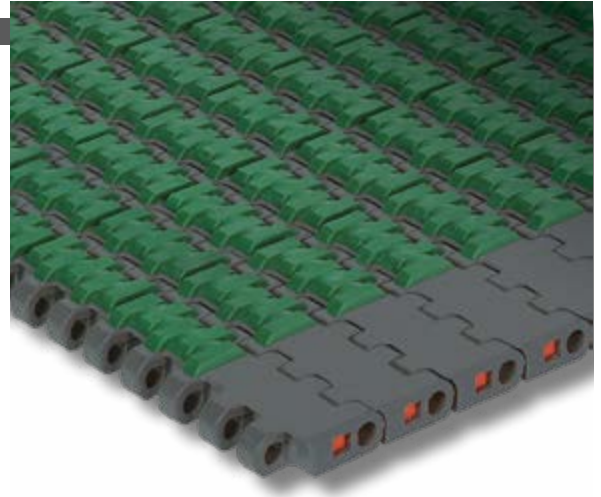

VERSION WITHOUT TRACKING GUIDE

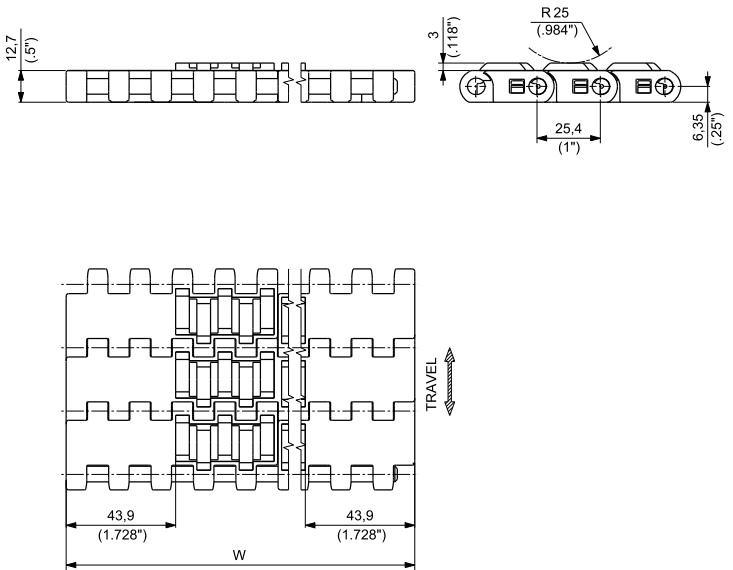

VERSION WITH TRACKING GUIDE

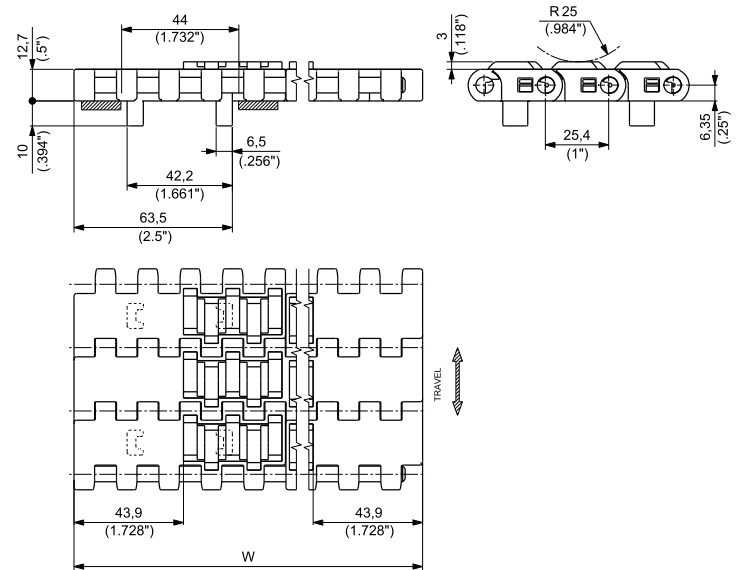

Materials  
see page 12



Sprockets  
see pages 241÷243



Applications  
see page 22

WIDTH W		MATERIALS				Rubber	Pin
		Module					
		ULF	ULTRA LOW FRICTION POLYESTER RESIN	PP	SPECIAL POLIPROPYLENE*		
		PART NUMBER		PART NUMBER			
mm	inches	WITHOUT TRACKING GUIDE	WITH TRACKING GUIDE	WITHOUT TRACKING GUIDE	WITH TRACKING GUIDE	THERMOPLASTIC <b>TPE</b> Hardness: 55 ShA for ULF material 50 ShA for PP material	POM for ULF material PBT for PP material
255	10.04	<b>HFSUMULF0255</b>	<b>HFSUMG1ULF0255</b>	<b>HFSUMPP0255</b>	<b>HFSUMG1PP0255</b>		
340	13.39	<b>HFSUMULF0340</b>	<b>HFSUMG1ULF0340</b>	<b>HFSUMPP0340</b>	<b>HFSUMG1PP0340</b>		
425	16.73	<b>HFSUMULF0425</b>	<b>HFSUMG1ULF0425</b>	<b>HFSUMPP0425</b>	<b>HFSUMG1PP0425</b>		
510	20.08	<b>HFSUMULF0510</b>	<b>HFSUMG1ULF0510</b>	<b>HFSUMPP0510</b>	<b>HFSUMG1PP0510</b>		
595	23.43	<b>HFSUMULF0595</b>	<b>HFSUMG1ULF0595</b>	<b>HFSUMPP0595</b>	<b>HFSUMG1PP0595</b>		
680	26.77	<b>HFSUMULF0680</b>	<b>HFSUMG1ULF0680</b>	<b>HFSUMPP0680</b>	<b>HFSUMG1PP0680</b>		
765	30.12	<b>HFSUMULF0765</b>	<b>HFSUMG1ULF0765</b>	<b>HFSUMPP0765</b>	<b>HFSUMG1PP0765</b>		
850	33.46	<b>HFSUMULF0850</b>	<b>HFSUMG1ULF0850</b>	<b>HFSUMPP0850</b>	<b>HFSUMG1PP0850</b>		
935	36.81	<b>HFSUMULF0935</b>	<b>HFSUMG1ULF0935</b>	<b>HFSUMPP0935</b>	<b>HFSUMG1PP0935</b>		
1020	40.16	<b>HFSUMULF1020</b>	<b>HFSUMG1ULF1020</b>	<b>HFSUMPP1020</b>	<b>HFSUMG1PP1020</b>		

Belts wider than 1020 mm (40.16") are available in 85 mm (3.35") increments.

To identify the Part Numbers, please substitute the last four digits of the PN with the desired width.

Example: for a 1105 mm wide belt (=1020+85 mm) without guide, the PN for ULF material is "HFSUMULF1105".

\*Actual width is larger than the nominal width.



Standard packaging:

Belt widths ≤ 425 mm (16.73") are supplied in rolls of 1,524 m (5 ft) each.

Belt widths ≥ 510 mm (20.08") are supplied in the length requested by the customer.



### 12,7 mm (0.5") THICKNESS LBP ROLLERS

Suitable for applications where a conveyor with a large accumulating section is needed.

- **Belt widths:** 85 mm (3.346") or wider in 85 mm (3.346") increments
- **Working Load (at 25°C/77°F):** 35000 N/m (2400 lbs/ft)
- **Belt weight:** 31,11 kg/m<sup>2</sup> (6.37 lbs/ft<sup>2</sup>)



#### VERSION WITHOUT TRACKING GUIDE

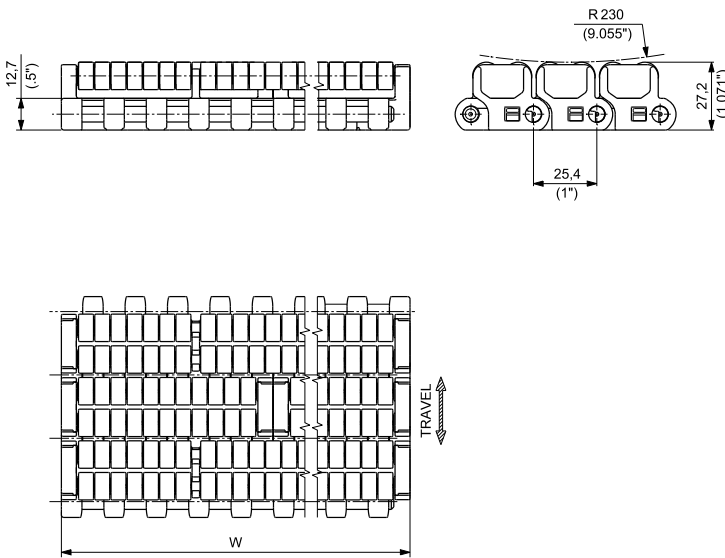

#### VERSION WITH TRACKING GUIDE

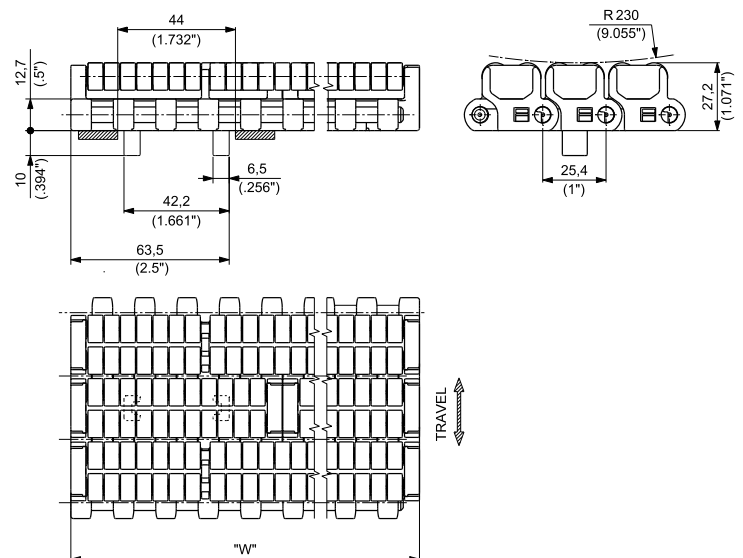

Matveyor



Materials  
see page 12



Sprockets  
see pages 241÷243



Applications  
see page 22

WIDTH W		MATERIALS	
		Module and roller	Pin
		<b>UP</b> ULTRA PERFORMANCE HOMOPOLYMER DELRIN®	
		PART NUMBER	
mm	inch	WITHOUT TRACKING GUIDE	WITH TRACKING GUIDE
85	3.35	<b>LBPUSPMUP0085</b>	<b>LBPUSPMGUP0085</b>
170	6.69	<b>LBPUSPMUP0170</b>	<b>LBPUSPMG1UP0170</b>
255	10.04	<b>LBPUSPMUP0255</b>	<b>LBPUSPMG1UP0255</b>
340	13.39	<b>LBPUSPMUP0340</b>	<b>LBPUSPMG1UP0340</b>
425	16.73	<b>LBPUSPMUP0425</b>	<b>LBPUSPMG1UP0425</b>
510	20.08	<b>LBPUSPMUP0510</b>	<b>LBPUSPMG1UP0510</b>
595	23.43	<b>LBPUSPMUP0595</b>	<b>LBPUSPMG1UP0595</b>
680	26.77	<b>LBPUSPMUP0680</b>	<b>LBPUSPMG1UP0680</b>
765	30.12	<b>LBPUSPMUP0765</b>	<b>LBPUSPMG1UP0765</b>
850	33.46	<b>LBPUSPMUP0850</b>	<b>LBPUSPMG1UP0850</b>
935	36.81	<b>LBPUSPMUP0935</b>	<b>LBPUSPMG1UP0935</b>
1020	40.16	<b>LBPUSPMUP1020</b>	<b>LBPUSPMG1UP1020</b>

Belts wider than 1020 mm (40.16") are available in 85 mm (3.35") increments.  
To identify the Part Numbers, please substitute the last four digits of the PN with the desired width.  
Example: for a 1105 mm wide belt (=1020+85 mm) without guide, the PN for UP material is "LBPUSPMUP1105".



**Standard packaging:**  
Belt widths ≤ 425 mm (16.73") are supplied in rolls of 1,524 m (5 ft) each.  
Belt widths ≥ 510 mm (20.09") and ≤ 935 (36.81") are supplied in rolls of 1,016 m (3.33 ft) each.  
Belt widths ≥ 1020 mm (40.16") are supplied in the length requested by the customer.

**11 mm (0.433") THICKNESS**  
**LBP ROLLERS**  
**SAFETY DESIGN**



Designed for product accumulation applications where a combination of high performance, improved safety and energy saving are required. LBP rollers allow for pressure reduction among accumulated products and for belt pull reduction.

- **Belt widths:** 85 mm (3.346") or wider in 85 mm (3.346") increments
- **Working Load (at 25°C/77°F):** 34000 N/m (2,330 lbs/ft)
- **Belt weight:** 19,40 kg/m<sup>2</sup> (3.97 lbs/ft<sup>2</sup>)

### VERSION WITHOUT TRACKING GUIDE

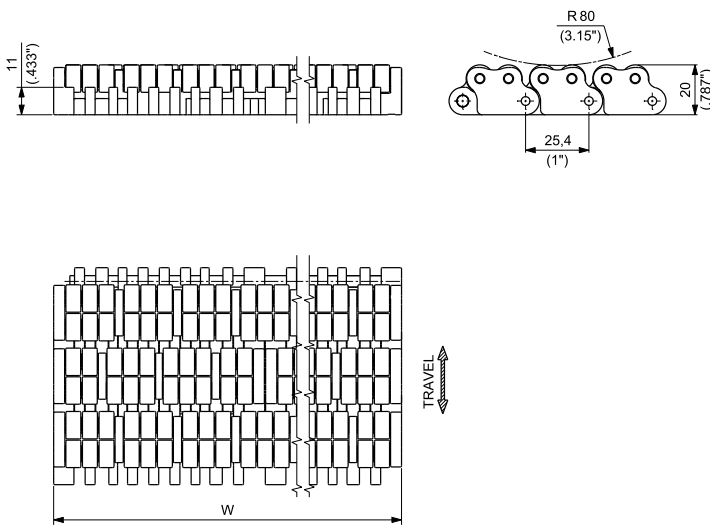

### VERSION WITH TRACKING GUIDE

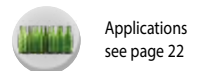
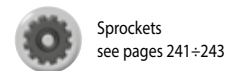
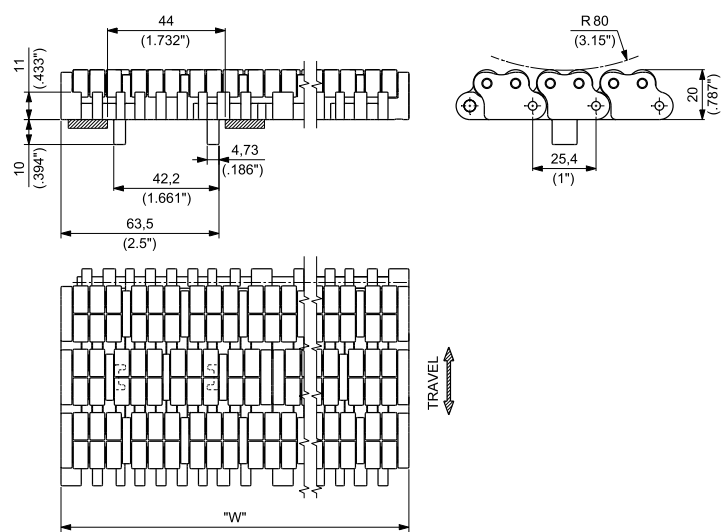

WIDTH W		MATERIALS		Pin
		Module and roller		
		<b>UP</b>	ULTRA PERFORMANCE HOMOPOLYMER DELRIN®	PBT
		PART NUMBER		
mm	inch	WITHOUT TRACKING GUIDE	WITH TRACKING GUIDE	
85	3.35	<b>LBPXSPMUP0085</b>	<b>LBPXSPMGUP0085</b>	
170	6.69	<b>LBPXSPMUP0170</b>	<b>LBPXSPMG1UP0170</b>	
255	10.04	<b>LBPXSPMUP0255</b>	<b>LBPXSPMG1UP0255</b>	
340	13.39	<b>LBPXSPMUP0340</b>	<b>LBPXSPMG1UP0340</b>	
425	16.73	<b>LBPXSPMUP0425</b>	<b>LBPXSPMG1UP0425</b>	
510	20.08	<b>LBPXSPMUP0510</b>	<b>LBPXSPMG1UP0510</b>	
595	23.43	<b>LBPXSPMUP0595</b>	<b>LBPXSPMG1UP0595</b>	
680	26.77	<b>LBPXSPMUP0680</b>	<b>LBPXSPMG1UP0680</b>	
765	30.12	<b>LBPXSPMUP0765</b>	<b>LBPXSPMG1UP0765</b>	
850	33.46	<b>LBPXSPMUP0850</b>	<b>LBPXSPMG1UP0850</b>	
935	36.81	<b>LBPXSPMUP0935</b>	<b>LBPXSPMG1UP0935</b>	
1020	40.16	<b>LBPXSPMUP1020</b>	<b>LBPXSPMG1UP1020</b>	

Belts wider than 1020 mm (40.16") are available in 85 mm (3.35") increments.  
 To identify the Part Numbers, please substitute the last four digits of the PN with the desired width.  
 Example: for a 1105 mm wide belt (=1020+85 mm) without guide, the PN is "LBPXSPMUP1105".



**Standard packaging:**  
 Belt widths ≤ 425 mm (16.73") are supplied in rolls of 1,524 m (5 ft) each.  
 Belt widths ≥ 510 mm (20.09") and ≤ 935 (36.81") are supplied in rolls of 1,016 m (3.33 ft) each.  
 Belt widths ≥ 1020 mm (40.16") are supplied in the length requested by the customer.

### 12,7 mm (0.5") THICKNESS SOLID TOP

Completely closed surface, no gap between modules, even when engaging on the sprockets. Particular suitable for glass products.

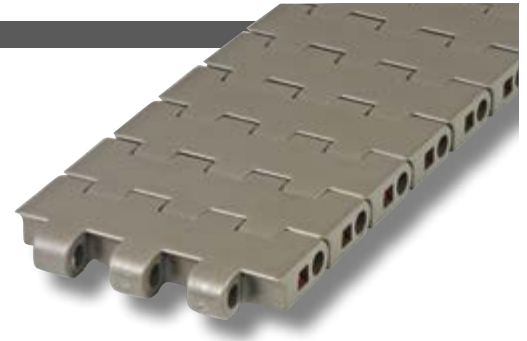

VERSION WITHOUT TRACKING GUIDE

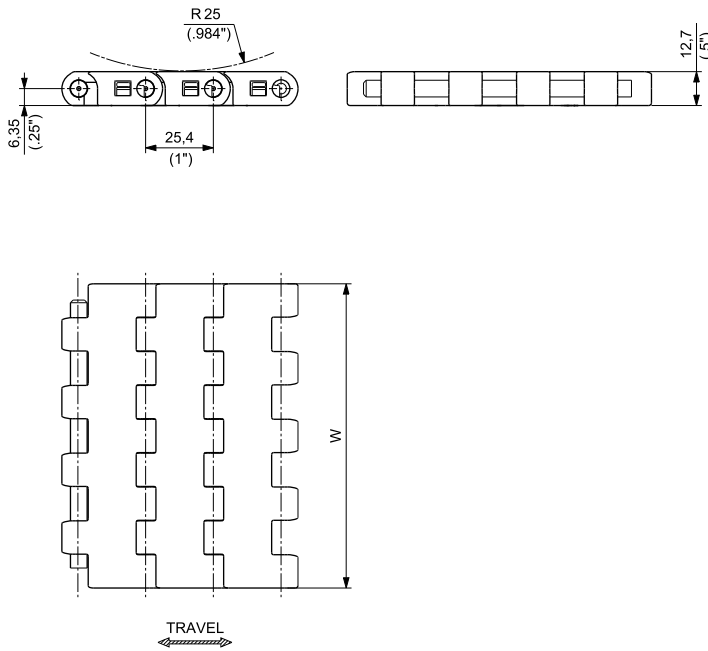

VERSION WITH TRACKING GUIDE

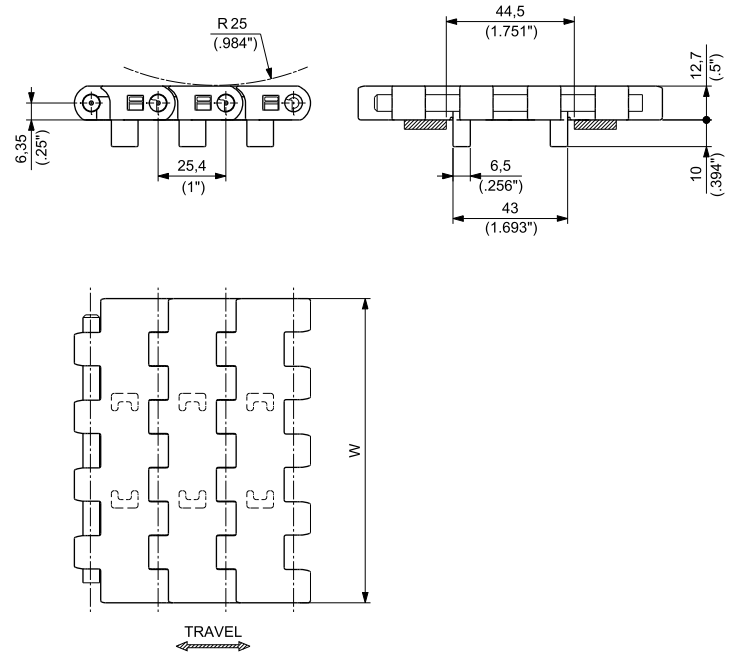

Materials  
see page 12



Sprockets  
see pages 241÷243



Applications  
see page 22

MATERIALS		VERSION	ITEM DESCRIPTION	PART NUMBER	WIDTH W		PLATE THICKNESS		WORKING LOAD (25°C/77°F)		WEIGHT	
Plate	Pin				mm	inch	mm	inch	N	lbs	kg/m	lbs/ft
ULTRA PERFORMANCE HOMOPOLYMER DELRIN® <b>UP</b>			USP UP 325	USPUPKD/000	82,6	3.25	12,7	0.50	2500	562	1,27	0.86
			USP UP 450	USPUPKG/000	114,3	4.50	12,7	0.50	3430	771	1,73	1.16
			USP UP 750	USPUPKL/000	190,5	7.50	12,7	0.50	5710	1284	2,83	1.90
SPECIAL DELRIN® REINFORCED WITH KEVLAR® <b>DK<sup>2</sup></b>	PBT	WITHOUT TRACKING GUIDE	USP D2K 325	USPD2KKD/000	82,6	3.25	12,7	0.50	2500	562	1,27	0.86
			USP D2K 450	USPD2KKG/000	114,3	4.50	12,7	0.50	3430	771	1,73	1.16
			USP D2K 750	USPD2KKL/000	190,5	7.50	12,7	0.50	5710	1284	2,83	1.90
ABRASION RESISTANT POLYAMIDE* <b>AR</b>			USP AR 325	USPARKD/000	82,6	3.25	12,7	0.50	2500	562	1,23	0.82
			USP AR 450	USPARKG/000	114,3	4.50	12,7	0.50	3430	771	1,67	1.12
			USP AR 750	USPARKL/000	190,5	7.50	12,7	0.50	5710	1284	2,73	1.83
ULTRA PERFORMANCE HOMOPOLYMER DELRIN® <b>UP</b>			USPG UP 325	USPGUPKD/000	82,6	3.25	12,7	0.50	2500	562	1,27	0.86
			USPG UP 450	USPGUPKG/000	114,3	4.50	12,7	0.50	3430	771	1,73	1.16
			USPG UP 750	USPGUPKL/000	190,5	7.50	12,7	0.50	5710	1284	2,83	1.90
SPECIAL DELRIN® REINFORCED WITH KEVLAR® <b>DK<sup>2</sup></b>	PBT	WITH TRACKING GUIDE	USPG D2K 325	USPGD2KKD/000	82,6	3.25	12,7	0.50	2500	562	1,27	0.86
			USPG D2K 450	USPGD2KKG/000	114,3	4.50	12,7	0.50	3430	771	1,73	1.16
			USPG D2K 750	USPGD2KKL/000	190,5	7.50	12,7	0.50	5710	1284	2,83	1.90
ABRASION RESISTANT POLYAMIDE* <b>AR</b>			USPG AR 325	USPGARKD/000	82,6	3.25	12,7	0.50	2500	562	1,23	0.82
			USPG AR 450	USPGARKG/000	114,3	4.50	12,7	0.50	3430	771	1,67	1.12
			USPG AR 750	USPGARKL/000	190,5	7.50	12,7	0.50	5710	1284	2,73	1.83

\*Actual width is larger than the nominal width.



Standard packaging:  
Rolls of 3,048 m (10 feet)

### 12,7 mm (0.5") THICKNESS SOLID TOP

Completely closed surface, no gap between the modules, even when engaging on the sprockets. Particular suitable for glass products.

- **Belt widths:** 154,2 mm (6") or wider in 76,2 mm (3") increments
- **Working Load (at 25°C/77°F):** 30000 N/m (2400 lbs/ft) for **UP**, **DK2** and **AR** materials
- **Belt weight:** 13,93 kg/m<sup>2</sup> (2.85 lbs/ft<sup>2</sup>) for **UP** and **DK2** materials  
13,40 kg/m<sup>2</sup> (2.74 lbs/ft<sup>2</sup>) for **AR** material

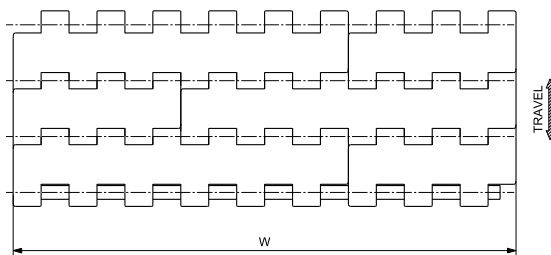
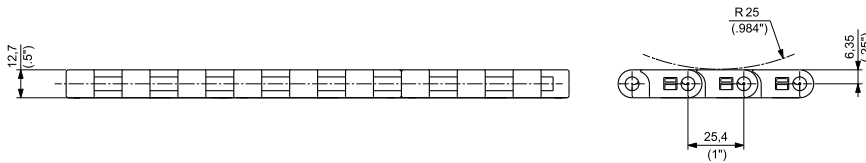
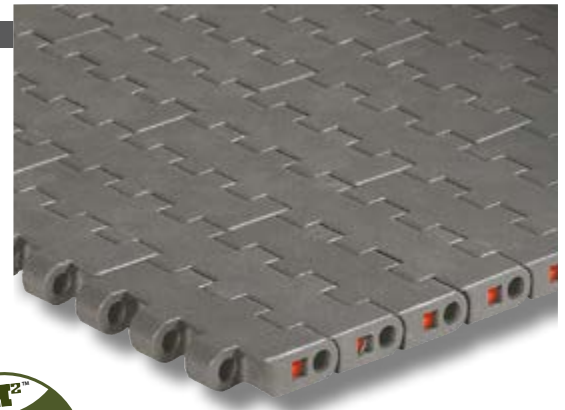

Materials see page 12



Sprockets see pages 241+243



Applications see page 22

WIDTH W		MATERIALS			
		Module			Pin
		<b>UP</b> ULTRA PERFORMANCE HOMOPOLYMER DELRIN®	<b>DK2</b> SPECIAL DELRIN® REINFORCED WITH KEVLAR®	<b>AR</b> ABRASION RESISTANT POLYAMIDE*	
mm	inch	PART NUMBER	PART NUMBER	PART NUMBER	PBT
152,20	6.0	<b>USPUP006</b>	<b>USPD2K006</b>	<b>USPAR006</b>	
228,60	9.0	<b>USPUP009</b>	<b>USPD2K009</b>	<b>USPAR009</b>	
304,80	12.0	<b>USPUP012</b>	<b>USPD2K012</b>	<b>USPAR012</b>	
381,00	15.0	<b>USPUP015</b>	<b>USPD2K015</b>	<b>USPAR015</b>	
457,20	18.0	<b>USPUP018</b>	<b>USPD2K018</b>	<b>USPAR018</b>	
533,40	21.0	<b>USPUP021</b>	<b>USPD2K021</b>	<b>USPAR021</b>	
609,60	24.0	<b>USPUP024</b>	<b>USPD2K024</b>	<b>USPAR024</b>	
685,80	27.0	<b>USPUP027</b>	<b>USPD2K027</b>	<b>USPAR027</b>	
762,00	30.0	<b>USPUP030</b>	<b>USPD2K030</b>	<b>USPAR030</b>	
838,20	33.0	<b>USPUP033</b>	<b>USPD2K033</b>	<b>USPAR033</b>	
914,40	36.0	<b>USPUP036</b>	<b>USPD2K036</b>	<b>USPAR036</b>	
996,60	39.0	<b>USPUP039</b>	<b>USPD2K039</b>	<b>USPAR039</b>	
1066,80	42.0	<b>USPUP042</b>	<b>USPD2K042</b>	<b>USPAR042</b>	
1143,00	45.0	<b>USPUP045</b>	<b>USPD2K045</b>	<b>USPAR045</b>	
1219,20	48.0	<b>USPUP048</b>	<b>USPD2K048</b>	<b>USPAR048</b>	
1295,40	51.0	<b>USPUP051</b>	<b>USPD2K051</b>	<b>USPAR051</b>	
1371,60	54.0	<b>USPUP054</b>	<b>USPD2K054</b>	<b>USPAR054</b>	
1447,80	57.0	<b>USPUP057</b>	<b>USPD2K057</b>	<b>USPAR057</b>	
1524,00	60.0	<b>USPUP060</b>	<b>USPD2K060</b>	<b>USPAR060</b>	

Belts wider than 1524 mm (60") are available in 76,2 (3") increments.  
To identify the Part Numbers, please substitute the last three digits of the PN with the desired width.  
Example: for a 63" wide belt (=60+3 inches), the PN for UP material is "USPUP063".  
Available on request increments of 25,4 mm (1").  
Example: 48+1=49 inches width, the PN for UP material is "USPUP049".  
\*Actual width is larger than the nominal width.



**Standard packaging:**

Belts are supplied in the length requested by the customer.

### ACTIVE TRANSFER MODULES 12,7 mm (0.5") THICKNESS SOLID TOP



To be used in combination with USP belt series.  
Active transfer modules USPG ATM series allow the transfer of the products between two 90° conveyor tracks without using dead plates. The special module profile, wing shaped, supports the products dynamically during transfer on the take-away belt. Available left and right version.

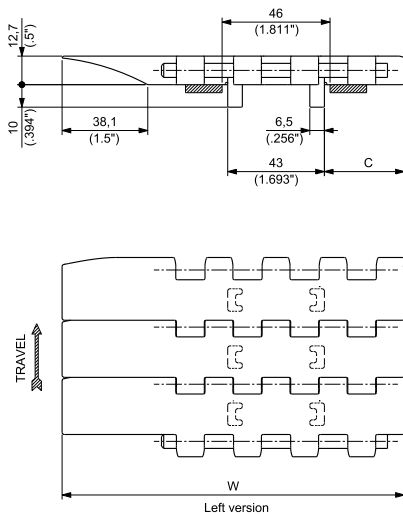

**K 4½": C= 35,5 mm (1.398")**  
**K 7½": C= 73,6 mm (2.898")**

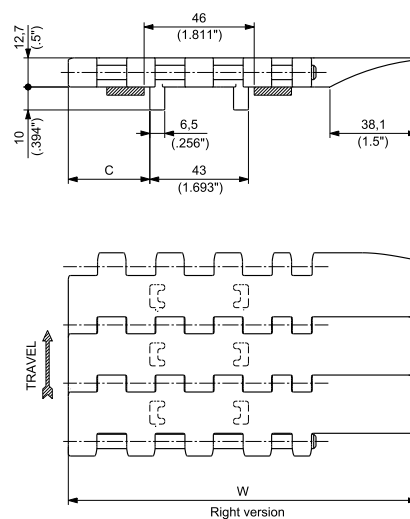

**K 4½": C= 35,5 mm (1.398")**  
**K 7½": C= 73,6 mm (2.898")**



Materials  
see page 12



Sprockets  
see pages 241÷243



Applications  
see page 22

#### USPG ATM - Left Version

MATERIALS		ITEM DESCRIPTION	PART NUMBER	WIDTH W		PLATE THICKNESS		WORKING LOAD (25°C/77°F)		WEIGHT	
Plate	Pin			mm	inch	mm	inch	N	lbs	kg/m	lbs/ft
ULTRA PERFORMANCE HOMOPOLYMER DELRIN® <b>UP</b>	PBT	USPGATM UP 450 SX	USPGATMUP450S	152,4	6.0	12,7	0.5	3480	782	1,97	1.32
		USPGATM UP 750 SX	USPGATMUP750S	228,6	9.0	12,7	0.5	5715	1285	3,06	2.05
SPECIAL DELRIN® REINFORCED WITH KEVLAR® <b>DK2</b>	PBT	USPGATM D2K 450 SX	USPGATMD2K450S	152,4	6.0	12,7	0.5	3480	782	1,97	1.32
		USPGATM D2K 750 SX	USPGATMD2K750S	228,6	9.0	12,7	0.5	5715	1285	3,06	2.05
ABRASION RESISTANT POLYAMIDE* <b>AR</b>	PBT	USPGATM AR 450 SX	USPGATMAR450S	152,4	6.0	12,7	0.5	3480	782	1,97	1.32
		USPGATM AR 750 SX	USPGATMAR750S	228,6	9.0	12,7	0.5	5715	1285	3,06	2.05

#### USPG ATM - Right Version

MATERIALS		ITEM DESCRIPTION	PART NUMBER	WIDTH W		PLATE THICKNESS		WORKING LOAD (25°C/77°F)		WEIGHT	
Plate	Pin			mm	inch	mm	inch	N	lbs	kg/m	lbs/ft
ULTRA PERFORMANCE HOMOPOLYMER DELRIN® <b>UP</b>	PBT	USPGATM UP 450 DX	USPGATMUP450D	152,4	6.0	12,7	0.5	3480	782	1,97	1.32
		USPGATM UP 750 DX	USPGATMUP750D	228,6	9.0	12,7	0.5	5715	1285	3,06	2.05
SPECIAL DELRIN® REINFORCED WITH KEVLAR® <b>DK2</b>	PBT	USPGATM D2K 450 DX	USPGATMD2K450D	152,4	6.0	12,7	0.5	3480	782	1,97	1.32
		USPGATM D2K 750 DX	USPGATMD2K750D	228,6	9.0	12,7	0.5	5715	1285	3,06	2.05
ABRASION RESISTANT POLYAMIDE* <b>AR</b>	PBT	USPGATM AR 450 DX	USPGATMAR450D	152,4	6.0	12,7	0.5	3480	782	1,97	1.32
		USPGATM AR 750 DX	USPGATMAR750D	228,6	9.0	12,7	0.5	5715	1285	3,06	2.05

\*Actual width is larger than the nominal width.



Standard packaging:  
Rolls of 3,048 m (10 feet)

## SUITABLE FOR CHAINS:

- USPM
- USP
- LBP USPM
- LBP XSPM
- HF USPM / HFS USPM

## MATERIALS

SPROCKETS: **PA** POLYAMIDE

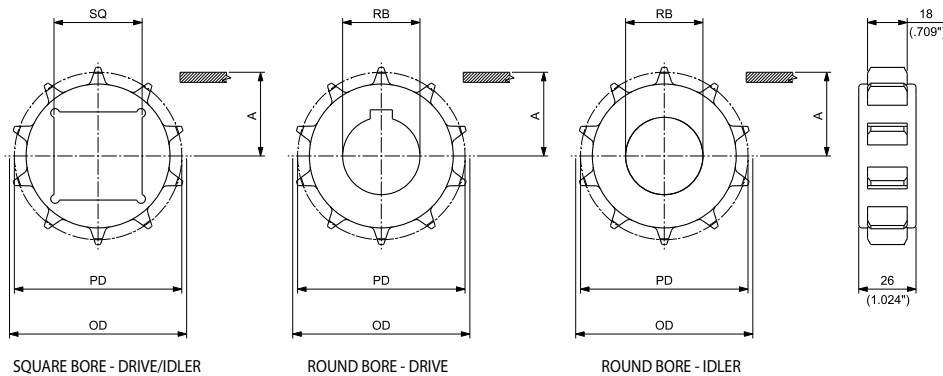
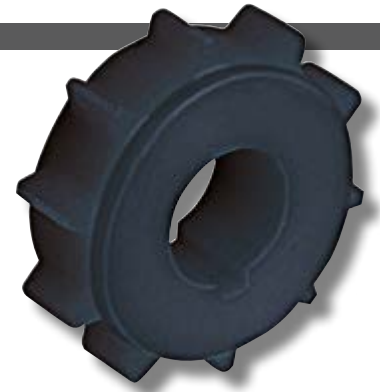

## MACHINED SOLID DRIVE AND IDLER SPROCKETS

N. TEETH	PITCH DIAMETER PD		OUTSIDE DIAMETER OD		WEAR STRIP POSITIONING A		BORE SIZE*		SQUARE BORE SQ DRIVE/IDLER	PART NUMBER		WEIGHT	
	mm	inch	mm	inch	mm	inch	mm	inch**		DRIVE	ROUND BORE RB IDLER	Kg	lbs
8	66,37	2.613	63,80	2.512	26,80	1.055	20			MPBATUSP0820	MPBAFUSP0820	0,05	0.11
							25			MPBATUSP0825	MPBAFUSP0825	0,05	0.10
							30			MPBATUSP0830	MPBAFUSP0830	0,04	0.09
							1			MPBATUSP08254	MPBAFUSP08254	0,05	0.10
							1 3/16			MPBATUSP08301	MPBAFUSP08301	0,04	0.09
							1 1/4			MPBATUSP08317	MPBAFUSP08317	0,04	0.08
10	82,19	3.236	80,40	3.165	34,70	1.366	30		MPBAQUSP1030	MPBATUSP1030	MPBAFUSP1030	0,09	0.19
							35			MPBATUSP1035	MPBAFUSP1035	0,08	0.17
							40		MPBAQUSP1040	MPBATUSP1040	MPBAFUSP1040	0,07	0.15
							1			MPBATUSP10254	MPBAFUSP10254	0,09	0.20
							1 3/16			MPBATUSP10301	MPBAFUSP10301	0,09	0.19
							1 1/4			MPBATUSP10317	MPBAFUSP10317	0,08	0.18

\*In case of round bore, diameter is indicated. In case of square bore, side of the square is indicated.

\*\* Imperial round bore drive sprockets are supplied with setscrew. Metric round bore drive sprockets are supplied without setscrew.





## SUITABLE FOR CHAINS:

- USPM
- USP
- LBP USPM
- LBP XSPM
- HF USPM / HFS USPM

MATERIALS	
SPROCKETS:	<b>PGF</b> REINFORCED POLYAMIDE
SCREW:	<b>SS</b> STAINLESS STEEL
NUTS:	<b>S+ZN</b> ZINC PLATED STEEL

## 12T, 13T, 14T, 15T & 16T SPROCKETS (for 18T & 21T see next page)

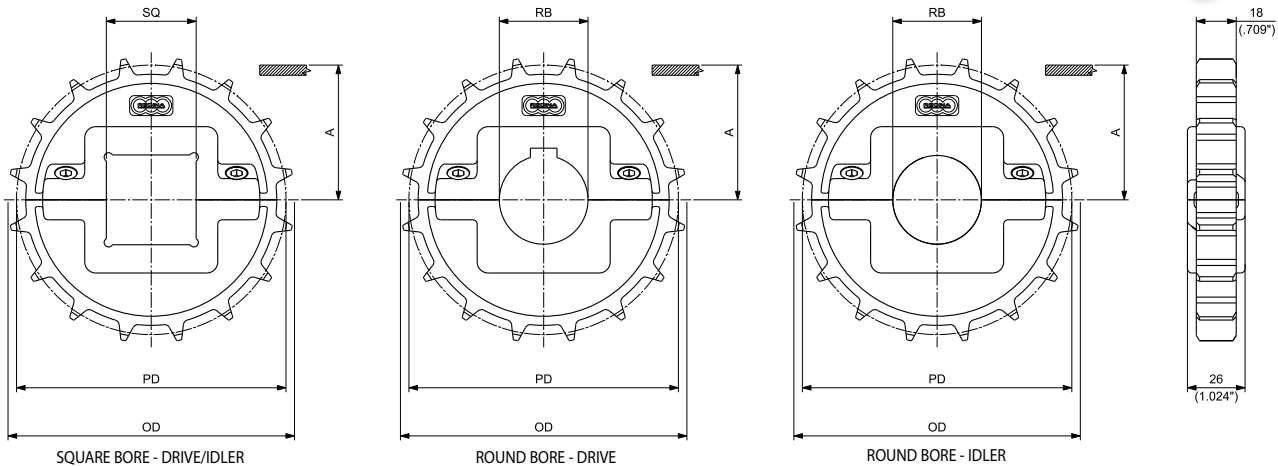

## MOULDED SPLIT DRIVE AND IDLER SPROCKETS

N. TEETH	PITCH DIAMETER PD		OUTSIDE DIAMETER OD		WEAR STRIP POSITIONING A		BORE SIZE*		PART NUMBER			WEIGHT	
	mm	inch	mm	inch	mm	inch	mm	inch**	SQUARE BORE SQ DRIVE/IDLER	ROUND BORE RB DRIVE	ROUND BORE RB IDLER	Kg	lbs
<b>NEW</b> 12	98,14	3.864	97,00	3.819	42,70	1.681	30		<b>MPBSTUSP1230</b>	<b>MPBSFUSP1230</b>		0,12	0.27
							35		<b>MPBSTUSP1235</b>	<b>MPBSFUSP1235</b>		0,12	0.26
							40		<b>MPBSTUSP1240</b>	<b>MPBSFUSP1240</b>		0,11	0.25
							1		<b>MPBSTUSP12254</b>	<b>MPBSFUSP12254</b>		0,13	0.28
							1¼		<b>MPBSTUSP12317</b>	<b>MPBSFUSP12317</b>		0,12	0.27
							1½	<b>MPBSQUSP13381</b>				0,11	0.24
<b>NEW</b> 13	106,14	4.179	105,50	4.154	46,70	1.839	30		<b>MPBSTUSP1330</b>	<b>MPBSFUSP1330</b>		0,12	0.26
							35		<b>MPBSTUSP1335</b>	<b>MPBSFUSP1335</b>		0,11	0.25
							40		<b>MPBSTUSP1340</b>	<b>MPBSFUSP1340</b>		0,11	0.24
							1		<b>MPBSTUSP13254</b>	<b>MPBSFUSP13254</b>		0,12	0.27
							1¼		<b>MPBSTUSP13317</b>	<b>MPBSFUSP13317</b>		0,12	0.26
							1½	<b>MPBSQUSP13381</b>				0,11	0.24
<b>NEW</b> 14	114,15	4.494	113,15	4.455	50,70	1.996	30		<b>MPBSTUSP1430</b>	<b>MPBSFUSP1430</b>		0,15	0.33
							35		<b>MPBSTUSP1435</b>	<b>MPBSFUSP1435</b>		0,14	0.32
							40	<b>MPBSQUSP1440</b>	<b>MPBSTUSP1440</b>	<b>MPBSFUSP1440</b>		0,14	0.30
							1		<b>MPBSTUSP14254</b>	<b>MPBSFUSP14254</b>		0,15	0.34
							1¼		<b>MPBSTUSP14317</b>	<b>MPBSFUSP14317</b>		0,15	0.32
							1½	<b>MPBSQUSP14381</b>	<b>MPBSTUSP14381</b>	<b>MPBSFUSP14381</b>		0,14	0.31
<b>NEW</b> 15	122,17	4.810	121,50	4.783	54,70	2.154	30		<b>MPBSTUSP1530</b>	<b>MPBSFUSP1530</b>		0,19	0.42
							35		<b>MPBSTUSP1535</b>	<b>MPBSFUSP1535</b>		0,18	0.40
							40	<b>MPBSQUSP1540</b>	<b>MPBSTUSP1540</b>	<b>MPBSFUSP1540</b>		0,18	0.39
							1		<b>MPBSTUSP15254</b>	<b>MPBSFUSP15254</b>		0,19	0.42
							1⅓		<b>MPBSTUSP15301</b>	<b>MPBSFUSP15301</b>		0,19	0.41
							1¼		<b>MPBSTUSP15317</b>	<b>MPBSFUSP15317</b>		0,19	0.41
							1⅕		<b>MPBSTUSP15365</b>	<b>MPBSFUSP15365</b>		0,18	0.40
							1½	<b>MPBSQUSP15381</b>	<b>MPBSTUSP15381</b>	<b>MPBSFUSP15381</b>		0,18	0.40
<b>NEW</b> 16	130,19	5.126	129,20	5.087	58,80	2.315	30		<b>MPBSTUSP1630</b>	<b>MPBSFUSP1630</b>		0,20	0.44
							35		<b>MPBSTUSP1635</b>	<b>MPBSFUSP1635</b>		0,20	0.43
							40	<b>MPBSQUSP1640</b>	<b>MPBSTUSP1640</b>	<b>MPBSFUSP1640</b>		0,19	0.42
							45		<b>MPBSTUSP1645</b>	<b>MPBSFUSP1645</b>		0,18	0.40
							50		<b>MPBSTUSP1650</b>	<b>MPBSFUSP1650</b>		0,17	0.38
							1		<b>MPBSTUSP16254</b>	<b>MPBSFUSP16254</b>		0,20	0.45
							1⅓		<b>MPBSTUSP16301</b>	<b>MPBSFUSP16301</b>		0,20	0.44
							1¼		<b>MPBSTUSP16317</b>	<b>MPBSFUSP16317</b>		0,20	0.44
1⅕		<b>MPBSTUSP16365</b>	<b>MPBSFUSP16365</b>		0,19	0.43							
1½	<b>MPBSQUSP16381</b>	<b>MPBSTUSP16381</b>	<b>MPBSFUSP16381</b>		0,19	0.42							

\*In case of round bore, diameter is indicated. In case of square bore, side of the square is indicated.

\*\* Imperial round bore drive sprockets are supplied with setscrew. Metric round bore drive sprockets are supplied without setscrew.

## SUITABLE FOR CHAINS:

- USPM
- USP
- LBP USPM
- LBP XSPM
- HF USPM / HFS USPM

MATERIALS	
SPROCKETS:	<b>PGF</b> REINFORCED POLYAMIDE
SCREW:	<b>SS</b> STAINLESS STEEL
NUTS:	<b>S+ZN</b> ZINC PLATED STEEL



## 18T & 21T SPROCKETS

(for 12T, 13T, 14T, 15T & 16T see previous page)

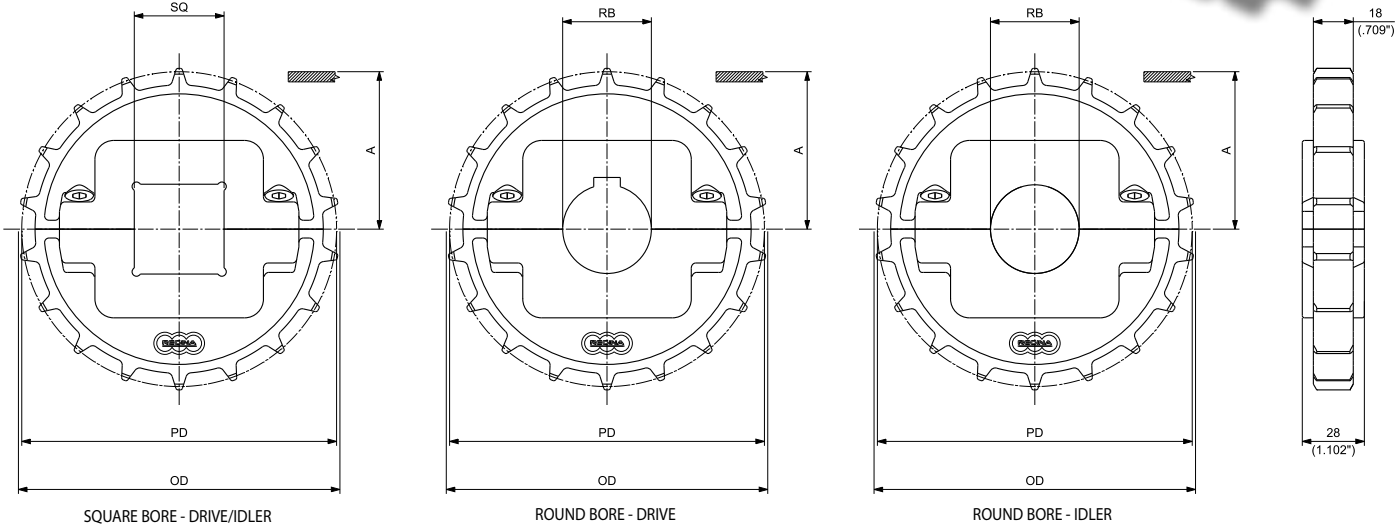

**MOULDED SOLID IDLER WHEELS**  
SEE PAGE 124



**MOULDED SPLIT IDLER WHEELS**  
SEE PAGE 193



**MACHINED SPLIT IDLER WHEELS**  
SEE PAGE 126

## MOULDED SPLIT DRIVE AND IDLER SPROCKETS

N. TEETH	PITCH DIAMETER PD		OUTSIDE DIAMETER OD		WEAR STRIP POSITIONING A		BORE SIZE*		SQUARE BORE SQ DRIVE/IDLER	PART NUMBER ROUND BORE RB		WEIGHT		
	mm	inch	mm	inch	mm	inch	mm	inch**		DRIVE	IDLER	Kg	lbs	
18	146,27	5.759	145,00	5.709	66,79	2.629				MPBSTUSP1830	MPBSFUSP1830	0,33	0.73	
										MPBSTUSP1835	MPBSFUSP1835	0,32	0.71	
									MPBSQUSP1840	MPBSTUSP1840	MPBSFUSP1840	0,32	0.70	
										MPBSTUSP1845	MPBSFUSP1845	0,31	0.68	
									MPBSQUSP1850	MPBSTUSP1850	MPBSFUSP1850	0,30	0.66	
									MPBSQUSP1860	MPBSTUSP1860	MPBSFUSP1860	0,28	0.61	
									MPBSQUSP1865			0,24	0.52	
									1	MPBSTUSP18254	MPBSFUSP18254	0,34	0.74	
									1 3/16	MPBSTUSP18301	MPBSFUSP18301	0,33	0.73	
									1 1/4	MPBSTUSP18317	MPBSFUSP18317	0,33	0.72	
									1 1/8	MPBSTUSP18365	MPBSFUSP18365	0,32	0.71	
									1 1/2	MPBSQUSP18381	MPBSTUSP18381	MPBSFUSP18381	0,32	0.70
									2	MPBSTUSP18508	MPBSFUSP18508	0,30	0.65	
									21	170,42	6.709	170,00	6.693	78,84
	MPBSTUSP2135	MPBSFUSP2135	0,39	0.86										
MPBSQUSP2140	MPBSTUSP2140	MPBSFUSP2140	0,38	0.85										
	MPBSTUSP2145	MPBSFUSP2145	0,38	0.83										
MPBSQUSP2150	MPBSTUSP2150	MPBSFUSP2150	0,37	0.81										
MPBSQUSP2160	MPBSTUSP2160	MPBSFUSP2160	0,34	0.76										
MPBSQUSP2165			0,31	0.67										
1	MPBSTUSP21254	MPBSFUSP21254	0,40	0.89										
1 3/16	MPBSTUSP21301	MPBSFUSP21301	0,40	0.88										
1 1/4	MPBSTUSP21317	MPBSFUSP21317	0,40	0.88										
1 1/8	MPBSTUSP21365	MPBSFUSP21365	0,39	0.86										
1 1/2	MPBSQUSP21381	MPBSTUSP21381	MPBSFUSP21381	0,39	0.85									
2	MPBSTUSP21508	MPBSFUSP21508	0,36	0.80										

\*In case of round bore, diameter is indicated. In case of square bore, side of the square is indicated.

\*\* Imperial round bore drive sprockets are supplied with setscrew. Metric round bore drive sprockets are supplied without setscrew.



PERFORMANCE IN MOTION

# Matveyor<sup>®</sup>

## 1" Pitch Sideflexing Chains



## INDUSTRIES AND APPLICATIONS

Suitable for handling loose products, such as plastic & glass bottles and aluminium & steel cans in the following industries and applications.

### INDUSTRIES

Bottling and canning  
 Container manufacturing  
 Consumer goods

### APPLICATIONS

Single lane & mass conveying  
 Pressureless inliners and combiners



## FEATURES

- 783 and 782 series can be used on conveyors side by side with 600, 610, 500, 300, 200, 1500, 1600, 7200, 7300 series due to the same thickness of 8,7mm for easy installation and standardization of wearstrips.
- Tab chains 783T series use the same curves as Fitetop plastic chains 880T, 879T series and Flitetop steel chains 881T and 981T series.

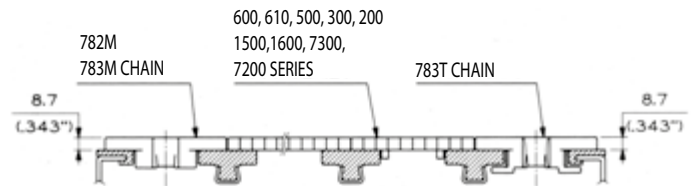

## INDUSTRIES AND APPLICATIONS

Suitable for handling loose products, such as plastic & glass bottles and aluminium & steel cans in the following industries and applications.

### INDUSTRIES

Bottling and canning  
 Container manufacturing  
 (in particular glass manufacturing)  
 Consumer goods

### APPLICATIONS

Single lane & mass conveying  
 Pressureless Inliners and combiners



## FEATURES

- 793 series can be used on conveyors side by side with USP, USPM, UCC series due to the same thickness of 12,7 mm for easy installation and standardization of wearstrips.
- Tab chains 793T series use the same curves as Flitetop plastic chains 880T, 879T series and steel chains 881T and 981T series.

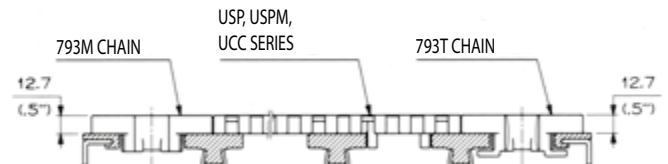

**TAB**  
**8,7 mm (0.343") THICKNESS**  
**SOLID TOP**  
**LIGHT DUTY**

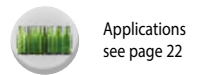
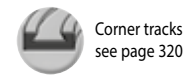
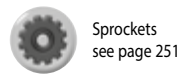
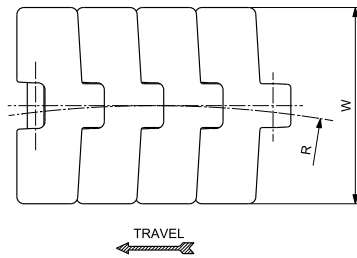
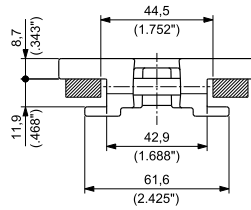
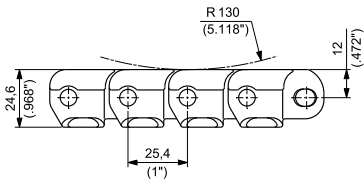

MATERIALS		ITEM DESCRIPTION	PART NUMBER	WIDTH W		PLATE THICKNESS		SIDEFLEXING RADIUS R		WORKING LOAD (25°C/77°F)		WEIGHT	
Plate	Pin			mm	Inch	mm	inch	mm	inch	N	lbs	kg/m	lbs/ft
ULTRA PERFORMANCE HOMOPOLYMER DELRIN® <b>UP</b>		UP 783T K 3 ¼	UP783TKD/000	82,6	3.25	8,7	0.343	457,2	18	1700	382	1,76	1.19
		UP 783T K 83,8	UP783TKRA/000	83,8	3.30	8,7	0.343	457,2	18	1700	382	1,78	1.19
		UP 783T K 4 ½	UP783TKG/000	114,3	4.50	8,7	0.343	609,6	24	1700	382	2,04	1.37
SPECIAL DELRIN® REINFORCED WITH KEVLAR® <b>D2K</b> AUSTENITIC STAINLESS STEEL		D2K 783T K 3 ¼	D2K783TKD/000	82,6	3.25	8,7	0.343	457,2	18	1700	382	1,76	1.19
		D2K 783T K 83,8	D2K783TKRA/000	83,8	3.30	8,7	0.343	457,2	18	1700	382	1,78	1.19
		D2K 783T K 4 ½	D2K783TKG/000	114,3	4.50	8,7	0.343	609,6	24	1700	382	2,04	1.37
<b>NEW</b> ECOLOGICAL FRICTION ABATING THERMOPLASTIC <b>E-FAST.</b>		EF 783T K 3 ¼	EF783TKD/000	82,6	3.25	8,7	0.343	457,2	18	1700	382	1,76	1.19
		EF 783T K 83,8	EF783TKRA/000	83,8	3.30	8,7	0.343	457,2	18	1700	382	1,78	1.19
		EF 783T K 4 ½	EF783TKG/000	114,3	4.50	8,7	0.343	609,6	24	1700	382	2,04	1.37

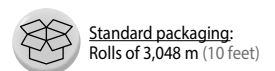



**MAGNETIC**

**8,7 mm (0.343") THICKNESS**

**SOLID TOP (783M) AND FLUSH GRID (782M)**

**LIGHT DUTY**



### 783M - SOLID TOP SURFACE

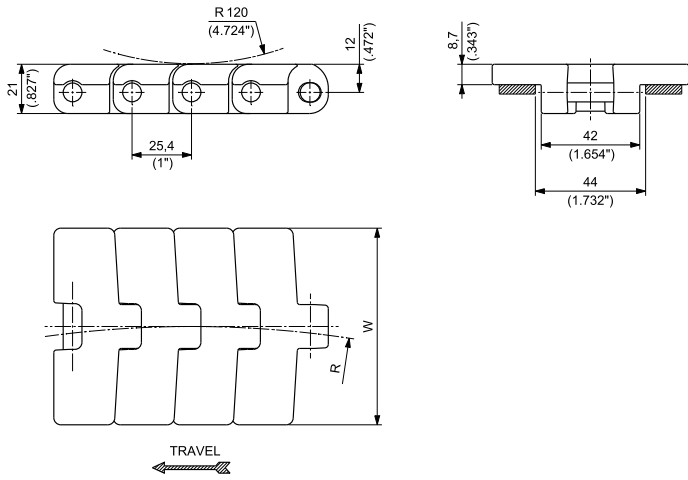

### 782M - FLUSH GRID SURFACE

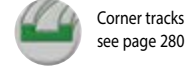
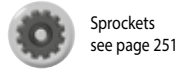
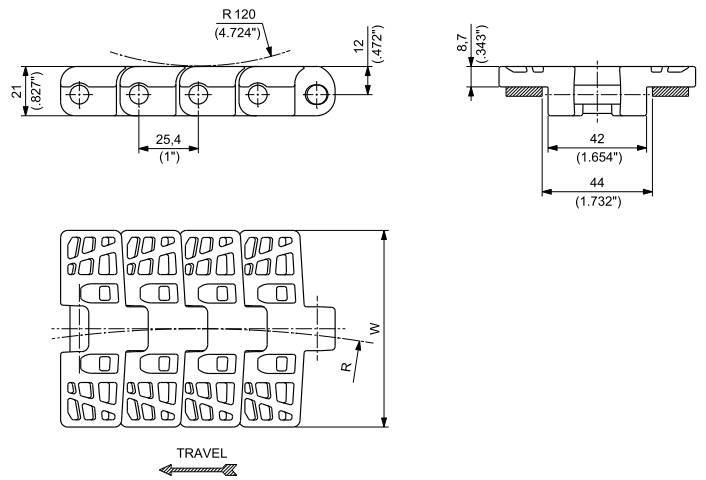

MATERIALS		SURFACE	ITEM DESCRIPTION	PART NUMBER	WIDTH W		PLATE THICKNESS		SIDEFLEXING RADIUS R		WORKING LOAD (25°C/77°F)		WEIGHT	
Plate	Pin				mm	inch	mm	inch	mm	inch	N	lbs	kg/m	lbs/ft
ULTRA PERFORMANCE HOMOPOLYMER DELRIN® <b>UP</b>			UP 783M K 83,8	UP783MKRA/000	83,8	3.30	8,7	0.343	500	19.69	1700	382	1,82	1.22
SPECIAL DELRIN® REINFORCED WITH KEVLAR® <b>DK2</b>		SOLID TOP	D2K 783M K 83,8	D2K783MKRA/000	83,8	3.30	8,7	0.343	500	19.69	1700	382	1,82	1.22
ECOLOGICAL FRICTION ABATING THERMOPLASTIC <b>e-FAST</b>			EF 783M K 83,8	EF783MKRA/000	83,8	3.30	8,7	0.343	500	19.69	1700	382	1,82	1.22
ULTRA PERFORMANCE HOMOPOLYMER DELRIN® <b>UP</b>		MAGNETIC STAINLESS STEEL	UP 782M K 83,8	UP782MKRA/000	83,8	3.30	8,7	0.343	500	19.69	1700	382	1,71	1.15
SPECIAL DELRIN® REINFORCED WITH KEVLAR® <b>DK2</b>		FLUSH GRID	D2K 782M K 83,8	D2K782MKRA/000	83,8	3.30	8,7	0.343	500	19.69	1700	382	1,71	1.15
ECOLOGICAL FRICTION ABATING THERMOPLASTIC <b>e-FAST</b>			EF 782M K 83,8	EF782MKRA/000	83,8	3.30	8,7	0.343	500	19.69	1700	382	1,71	1.15

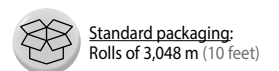



**TAB**  
**12,7 mm (0.5") THICKNESS**  
**SOLID TOP**  
**HEAVY DUTY**

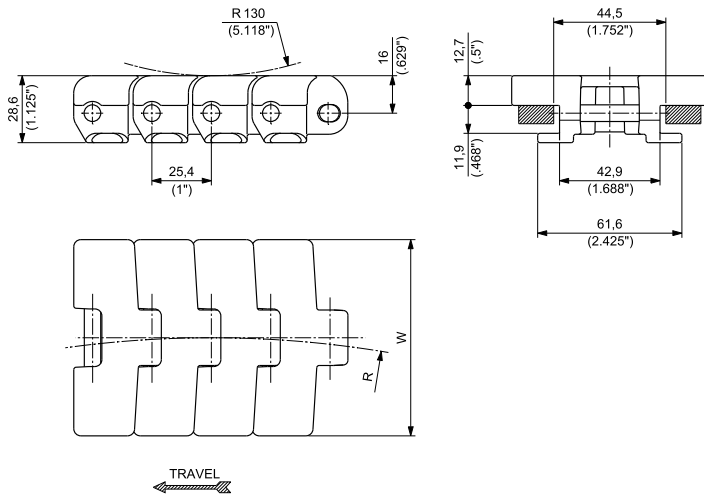

Matveyor®



Materials  
see page 12



Sprockets  
see page 251



Corner tracks  
see page 320



Applications  
see page 22

MATERIALS		ITEM DESCRIPTION	PART NUMBER	WIDTH W		PLATE THICKNESS		SIDEFLEXING RADIUS R		WORKING LOAD (25°C/77°F)		WEIGHT	
Plate	Pin			mm	inch	mm	inch	mm	inch	N	lbs	kg/m	lbs/ft
ULTRA PERFORMANCE HOMOPOLYMER DELRIN® <b>UP</b>		UP 793T K 3 ¼	UP793TKD/000	82,6	3.25	12,7	0.50	457,2	18	2200	495	2,09	1.41
		UP 793T K 83,8	UP793TKRA/000	83,8	3.30	12,7	0.50	457,2	18	2200	495	2,11	1.42
		UP 793T K 4 ½	UP793TKG/000	114,3	4.50	12,7	0.50	609,6	24	2200	495	2,48	1.67
SPECIAL DELRIN® REINFORCED WITH KEVLAR® AUSTENITIC STAINLESS STEEL <b>DK2</b>		D2K 793T K 3 ¼	D2K793TKD/000	82,6	3.25	12,7	0.50	457,2	18	2200	495	2,09	1.41
		D2K 793T K 83,8	D2K793TKRA/000	83,8	3.30	12,7	0.50	457,2	18	2200	495	2,11	1.42
		D2K 793T K 4 ½	D2K793TKG/000	114,3	4.50	12,7	0.50	609,6	24	2200	495	2,48	1.67
ABRASION RESISTANT POLYAMIDE* <b>AR</b>		AR 793T K 3 ¼	AR793TKD/000	82,6	3.25	12,7	0.50	457,2	18	2200	495	2,02	1.36
		AR 793T K 83,8	AR793TKRA/000	83,8	3.30	12,7	0.50	457,2	18	2200	495	2,04	1.37
		AR 793T K 4 ½	AR793TKG/000	114,3	4.50	12,7	0.50	609,6	24	2200	495	2,40	1.61

\*Actual width is larger than the nominal width.



Standard packaging:  
Rolls of 3,048 m (10 feet)

**MAGNETIC**  
**12,7 mm (0.5") THICKNESS**  
**SOLID TOP**  
**HEAVY DUTY**

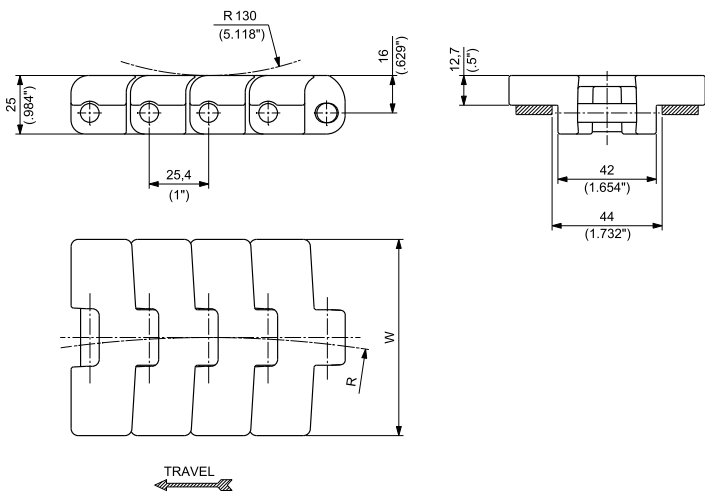

Materials  
see page 12



Sprockets  
see page 251



Corner tracks  
see page 280



Applications  
see page 22

MATERIALS		ITEM DESCRIPTION	PART NUMBER	WIDTH W		PLATE THICKNESS		SIDEFLEXING RADIUS R		WORKING LOAD (25°C/77°F)		WEIGHT	
Plate	Pin			mm	inch	mm	inch	mm	inch	N	lbs	kg/m	lbs/ft
ULTRA PERFORMANCE HOMOPOLYMER DELRIN® <b>UP</b>		UP 793M K 83,8	UP793MKRA/000	83,8	3.30	12,7	0.50	500	19.685	2200	495	2,10	1.41
		UP 793M K 4 ½	UP793MKG/000	114,3	4.50	12,7	0.50	500	19.685	2200	495	2,46	1.65
SPECIAL DELRIN® REINFORCED WITH KEVLAR® <b>DK2</b>	MAGNETIC STAINLESS STEEL	D2K 793M K 83,8	D2K793MKRA/000	83,8	3.30	12,7	0.50	500	19.685	2200	495	2,10	1.41
		D2K 793M K 4 ½	D2K793MKG/000	114,3	4.50	12,7	0.50	500	19.685	2200	495	2,46	1.65
ABRASION RESISTANT POLYAMIDE* <b>AR</b>		AR 793M K 83,8	AR793MKRA/000	83,8	3.30	12,7	0.50	500	19.685	2200	495	2,04	1.37
		AR 793M K 4 ½	AR793MKG/000	114,3	4.50	12,7	0.50	500	19.685	2200	495	2,38	1.60

\*Actual width is larger than the nominal width.



Standard packaging:  
Rolls of 3,048 m (10 feet)

**LOW PIN CENTER**  
**12,7 mm (0.5") THICKNESS**  
**SOLID TOP**  
**HEAVY DUTY**

**NEW**



The special Low Pin Center chain design holds the chains down flat and level in the curves, unlike conventional beveled and TAB chain styles, which lift up on the outer edges. This eliminates product tippage, especially on multi-strand conveyors. All of this comes without the extra cost of magnetic corner tracks. These chains can simply be lifted anywhere in the carry track for easy cleaning and maintenance.

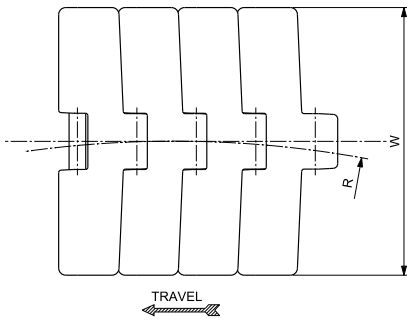
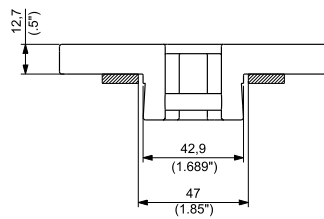
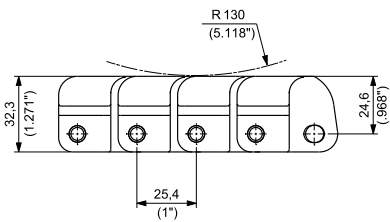

Matveyor®



Materials see page 12



Sprockets see page 251



Corner tracks see page 328



Applications see page 22

MATERIALS		ITEM DESCRIPTION	PART NUMBER	WIDTH W		PLATE THICKNESS		SIDEFLEXING RADIUS R		WORKING LOAD (25°C/77°F)		WEIGHT	
Plate	Pin			mm	inch	mm	inch	mm	inch	N	lbs	kg/m	lbs/ft
ULTRA PERFORMANCE HOMOPOLYMER DELRIN® <b>UP</b>		UP 793L K 4 ½	UP793LKG/000	114,3	4.5	12,7	0.50	609,6	24	2200	495	2,55	1.71
	AUSTENITIC STAINLESS STEEL												
SPECIAL DELRIN® REINFORCED WITH KEVLAR® <b>DK2</b>		D2K 793L K 4 ½	D2K793LKG/000	114,3	4.5	12,7	0.50	609,6	24	2200	495	2,55	1.71



Standard packaging:  
Rolls of 3,048 m (10 feet)

## SUITABLE FOR CHAINS:

- 782M
- 783M
- 783T
- 793M
- 793T
- 793L

MATERIALS	
SPROCKETS:	<b>PGF</b> REINFORCED POLYAMIDE
SCREW:	<b>SS</b> STAINLESS STEEL
NUTS:	<b>S+ZN</b> ZINC PLATED STEEL

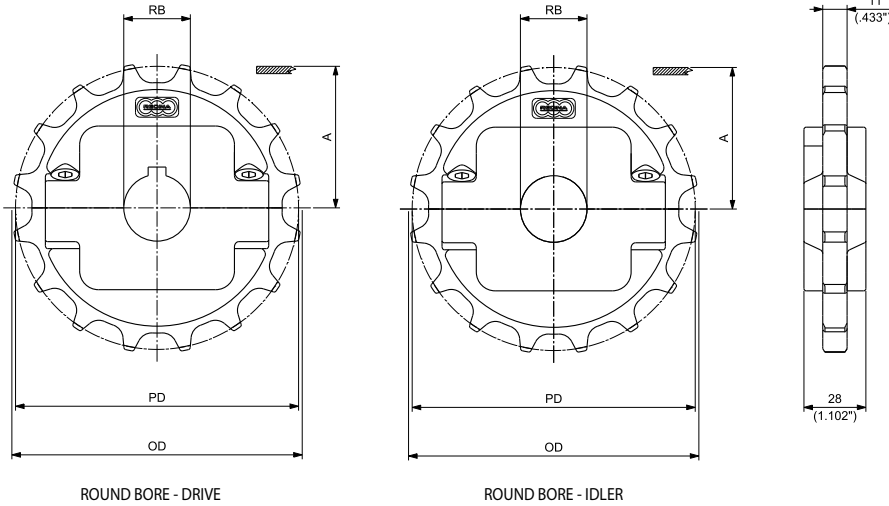

**MOULDED SOLID IDLER WHEELS FOR 782M, 783M, 793M CHAINS**  
SEE PAGE 124

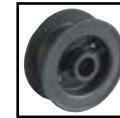

**MOULDED SPLIT IDLER WHEELS FOR 782M, 783M, 793M CHAINS**  
SEE PAGE 193



**MACHINED SPLIT IDLER WHEELS FOR 782M, 783M, 793M CHAINS**  
SEE PAGE 126

## MOULDED SPLIT DRIVE AND IDLER SPROCKETS

N. TEETH	PITCH DIAMETER PD		OUTSIDE DIAMETER OD		WEAR STRIP POSITIONING A		BORE SIZE*		PART NUMBER ROUND BORE RB		WEIGHT											
	mm	inch	mm	inch	mm	inch	mm	inch**	DRIVE	IDLER	Kg	lbs										
16	130,20	5.126	131,30	5.169	77,00	3.031			25	CMT027821601	CMT037821601	0,26	0.58									
									30	CMT027821602	CMT037821602	0,26	0.57									
									35	CMT027821603	CMT037821603	0,25	0.56									
									40	CMT027821604	CMT037821604	0,24	0.54									
									45	CMT027821605	CMT037821605	0,24	0.52									
									50	CMT027821613	CMT037821613	0,23	0.50									
										1	CMT027821606	CMT037821606	0,26	0.58								
										1 3/16	CMT027821607	CMT037821607	0,26	0.57								
										1 1/4	CMT027821608	CMT037821608	0,26	0.57								
										1 3/8	CMT027821611	CMT037821611	0,25	0.56								
										1 7/16	CMT027821609	CMT037821609	0,25	0.55								
										1 1/2	CMT027821610	CMT037821610	0,25	0.55								
									18	146,27	5.759	147,60	5.811	85,04	3.348			25	CMT027821801	CMT037821801	0,29	0.63
																		30	CMT027821802	CMT037821802	0,28	0.62
																		35	CMT027821803	CMT037821803	0,28	0.61
																		40	CMT027821804	CMT037821804	0,27	0.59
45	CMT027821805	CMT037821805	0,26	0.58																		
50	CMT027821813	CMT037821813	0,25	0.56																		
	1	CMT027821806	CMT037821806	0,29	0.63																	
	1 3/16	CMT027821807	CMT037821807	0,28	0.62																	
	1 1/4	CMT027821808	CMT037821808	0,28	0.62																	
	1 3/8	CMT027821811	CMT037821811	0,28	0.61																	
	1 7/16	CMT027821809	CMT037821809	0,27	0.60																	
	1 1/2	CMT027821810	CMT037821810	0,27	0.60																	
19	154,32	6.076	156,30	6.154	89,06	3.506												25	CMT027821901	CMT037821901	0,32	0.71
																		30	CMT027821902	CMT037821902	0,31	0.69
																		35	CMT027821903	CMT037821903	0,31	0.68
																		40	CMT027821904	CMT037821904	0,30	0.66
									45	CMT027821905	CMT037821905	0,29	0.65									
									50	CMT027821913	CMT037821913	0,28	0.63									
										1	CMT027821906	CMT037821906	0,32	0.70								
										1 3/16	CMT027821907	CMT037821907	0,31	0.69								
										1 1/4	CMT027821908	CMT037821908	0,31	0.69								
										1 3/8	CMT027821911	CMT037821911	0,31	0.68								
										1 7/16	CMT027821909	CMT037821909	0,31	0.68								
										1 1/2	CMT027821910	CMT037821910	0,30	0.67								

\*Diameter is indicated.

\*\* Imperial round bore drive sprockets are supplied with setscrew. Metric round bore drive sprockets are supplied without setscrew.



PERFORMANCE IN MOTION

# Matveyor<sup>®</sup>

## 1 1/4" Pitch Heavy Duty Sideflexing Belts



## INDUSTRIES AND APPLICATIONS

REGINA Sideflexing belts are suitable for packaging applications requiring speed and heavy packs carriage around curves, in particular: multi packs of plastic bottles, cartons, shrink wrapped cans.

### INDUSTRIES

Bottling & canning  
 Food filling  
 Pharmaceutical  
 Paper / Cardboard  
 Consumer goods



## BELT CONVEYING CAPABILITY

L-PATH

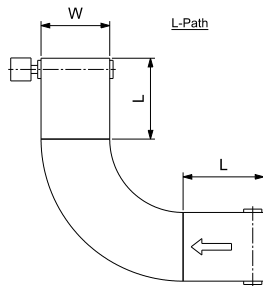

### APPLICATION EXAMPLE 1

- Belt width W: 850 mm
- Straight section L: 1200 mm
- Curve radius: 1600 mm
- Speed: 30 m/min
- Load: N°32 shrink packs 3x2 1.SL PET in double track
- Total weight on the conveyor: 290 kg

U-PATH

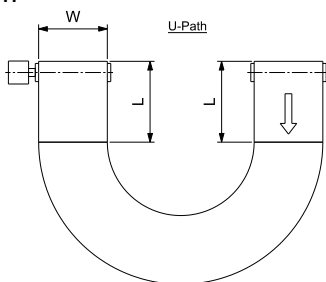

### APPLICATION EXAMPLE 2

- Belt width W: 850 mm
- Straight section L: 1200 mm
- Curve radius: 1600 mm
- Speed: 30 m/min
- Load: N°45 shrink packs 3x2 1.SL PET in double track
- Total weight on the conveyor: 400 kg

C-PATH

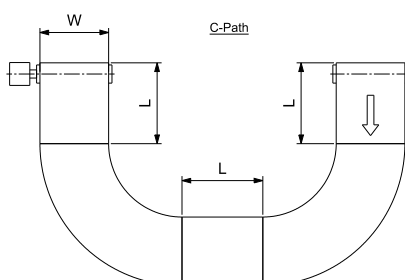

### APPLICATION EXAMPLE 3

- Belt width W: 850 mm
- Straight section L: 1200 mm
- Curve radius: 1600 mm
- Speed: 30 m/min
- Load: N°55 shrink packs 3x2 1L PET in double track
- Total weight on the conveyor: 330 kg
- N° 1 drive only to link two curves



## FEATURES

- Belt equipped with radial bearing.
- Split guide system to prevent overturning and provide radial force resistance in sideflexing section.



- Outer modules with reinforced hinges and larger cross-section.



- Available in tight radius version (SR):
  - Reinforced design of the inner modules
  - Minimum ratio (1.2) between inner radius of the curve and belt width.



- "Poka yoke" design of the outer hinges.



- Guide system suitable for conveyors frame with 44 mm guide clearance.

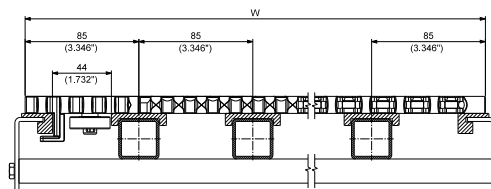

## BENEFITS

- Drastic friction reduction in curve sections.
- No curve overheating
  - Drastic wear and noise reduction
  - Smooth belt running
- No special material requirement for curve profile (UHMWPE standard)
  - Cost saving

- High conveying capability for the most demanding layouts:
  - 180° single curve
  - 2x90° curves

- Higher transversal and longitudinal stiffness.
- More compact curves for reduced footprint layout.

- Prevention of any assembling mistakes.

- Wear strips standardization.

**TAB+BEARING**  
**12,7 mm (0.5") THICKNESS**  
**REINFORCED OUTER MODULES**  
**STANDARD SIDEFLEXING RADIUS**

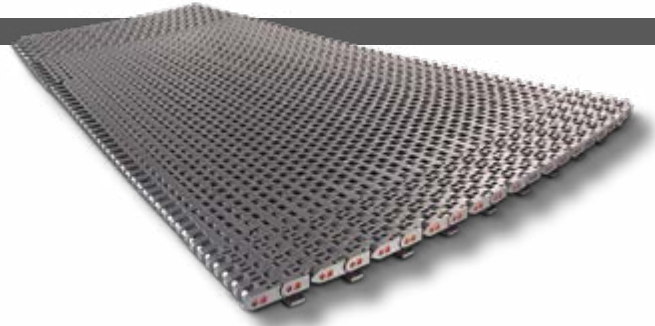

For traditional left, right or "U" turn conveying.  
 Average ratio between internal sideflexing radius and width = **1.8**.  
 Guide system with **one side TAB+ Stainless Steel Bearing (waterproof)**.

- **Belt widths:** from 255 mm (10.04") to 850 mm (33.46") in 85 mm (3.35") increments

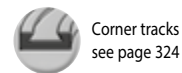
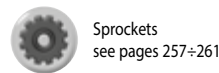
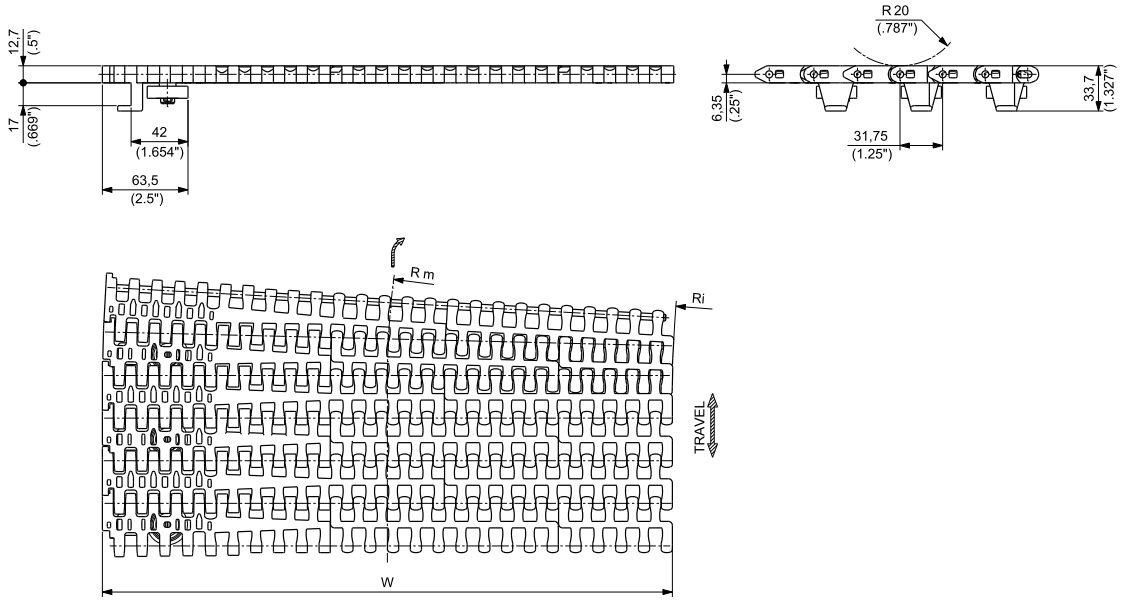

MATERIALS		PART NUMBER	WIDTH W		SIDEFLEXING RADIUS				WEIGHT	
Module	Pin		mm	inch	INNER Ri		MEDIUM Rm		kg/m	lbs/ft
ULTRA PERFORMANCE HOMOPOLYMER DELRIN® <b>UP</b>	PBT	<b>2556HTB-UP0255</b>	255	10.04	472,5	18.60	600	23.62	3,24	2.18
		<b>2556HTB-UP0340</b>	340	13.39	630,0	24.80	800	31.50	3,97	2.67
		<b>2556HTB-UP0425</b>	425	16.73	787,3	31.00	1000	39.37	4,70	3.16
		<b>2556HTB-UP0510</b>	510	20.08	945,0	37.21	1200	47.24	5,43	3.65
		<b>2556HTB-UP0595</b>	595	23.43	1102,5	43.41	1400	55.12	6,16	4.14
		<b>2556HTB-UP0680</b>	680	26.77	1260,0	49.61	1600	62.99	6,90	4.64
		<b>2556HTB-UP0765</b>	765	30.12	1417,5	55.81	1800	70.87	7,63	5.13
		<b>2556HTB-UP0850</b>	850	33.46	1575,0	62.01	2000	78.74	8,36	5.62

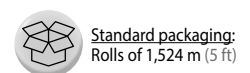

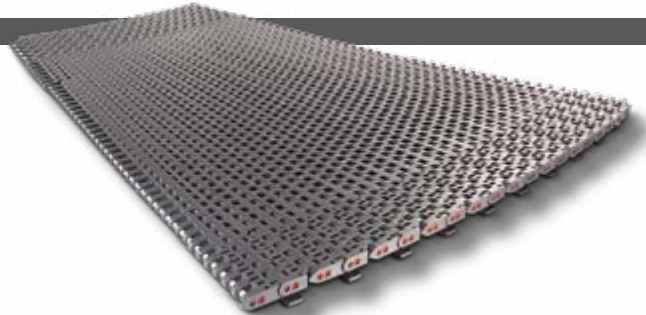

**TAB+BEARING**  
**12,7 mm (0.5") THICKNESS**  
**REINFORCED OUTER MODULES**  
**REDUCED SIDEFLEXING RADIUS**

For traditional left, right or "U" turn conveying.  
 Average ratio between internal sideflexing radius and width= **1.2**.  
 Suitable to be used in more compact conveyors, saving floor space.  
 For **heavy duty** applications with high working load and speed.  
 Guide system with **one side TAB+Stainless Steel Bearing (waterproof)**.

- **Belt widths:** from 340 mm (13.39") to 850 mm (33.46") in 85 mm (3.35") increments

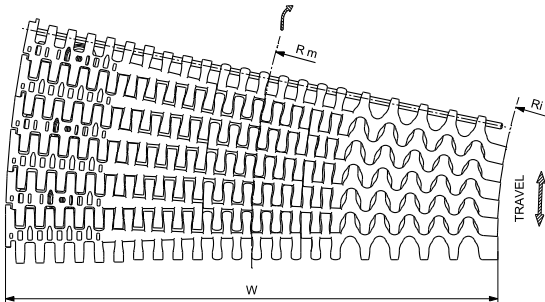
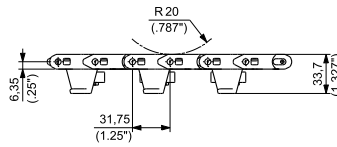
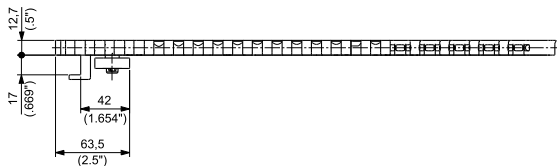

Matveyor



Materials  
see page 12



Sprockets  
see pages 257÷261



Corner tracks  
see page 324



Applications  
see page 22

MATERIALS		PART NUMBER	WIDTH W		SIDEFLEXING RADIUS				WEIGHT	
Module	Pin		mm	inch	INNER Ri		MEDIUM Rm		kg/m	lbs/ft
ULTRA PERFORMANCE HOMOPOLYMER DELRIN® <b>UP</b>	PBT	<b>2556HTB-SRUP0340</b>	340	13.39	330,0	12.99	500	19.69	3,91	2.63
		<b>2556HTB-SRUP0425</b>	425	16.73	387,5	15.26	600	23.62	4,70	3.16
		<b>2556HTB-SRUP0510</b>	510	20.08	545,0	21.46	800	31.50	5,43	3.65
		<b>2556HTB-SRUP0595</b>	595	23.43	702,5	27.66	1000	39.37	6,17	4.15
		<b>2556HTB-SRUP0680</b>	680	26.77	860,0	33.86	1200	47.24	6,90	4.64
		<b>2556HTB-SRUP0765</b>	765	30.12	1017,5	40.06	1400	55.12	7,63	5.13
		<b>2556HTB-SRUP0850</b>	850	33.46	1175,5	46.26	1600	62.99	8,36	5.62



Standard packaging:  
Rolls of 1,524 m (5 ft)

## SUITABLE FOR CHAINS:

- 2556HTB
- 2556HTB-SR

## MATERIALS

SPROCKETS: **PA** POLYAMIDE

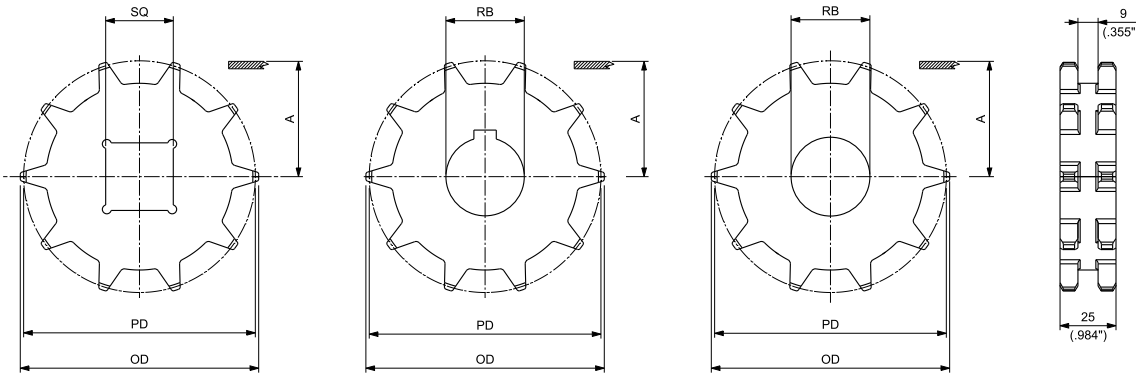

SQUARE BORE - DRIVE/IDLER

ROUND BORE - DRIVE

ROUND BORE - IDLER

## MACHINED DOUBLE ROW SOLID DRIVE AND IDLER SPROCKETS

N. TEETH	PITCH DIAMETER PD		OUTSIDE DIAMETER OD		WEAR STRIP POSITIONING A		BORE SIZE**		PART NUMBER			WEIGHT	
	mm	inch	mm	inch	mm	inch	mm	inch***	SQUARE BORE SQ DRIVE/IDLER	ROUND BORE RB DRIVE	ROUND BORE RB IDLER	Kg	lbs
8*	82,97	3.267	86,50	3.406	35,14	1.383	30		MPBAT255508D30	MPBAF255508D30		0,08	0.17
							35		MPBAT255508D35	MPBAF255508D35		0,07	0.16
							1		MPBAT255508D254	MPBAF255508D254		0,08	0.19
							1¼		MPBAT255508D317	MPBAF255508D317		0,08	0.17
10	102,75	4.045	106,50	4.193	45,03	1.773	30		MPBAT255510D30	MPBAF255510D30		0,15	0.32
							35		MPBAT255510D35	MPBAF255510D35		0,14	0.31
							40	MPBAQ255510D40	MPBAT255510D40	MPBAF255510D40		0,13	0.29
							1		MPBAT255510D254	MPBAF255510D254		0,16	0.34
							1¼		MPBAT255510D317	MPBAF255510D317		0,15	0.32
							1½	MPBAQ255510D381	MPBAT255510D381	MPBAF255510D381		0,14	0.30

\*For some shaft dimensions, shaft needs to be properly machined down to avoid interference with the belt tabs. Please contact REGINA Application Engineering for more details.

\*\*In case of round bore, diameter is indicated. In case of square bore, side of the square is indicated.

\*\*\* Imperial round bore drive sprockets are supplied with setscrew. Metric round bore drive sprockets are supplied without setscrew.

## SUITABLE FOR CHAINS:

- 2556HTB
- 2556HTB-SR

### MATERIALS

SPROCKETS:	<b>PA</b>	POLYAMIDE
SCREWS:	<b>SS</b>	STAINLESS STEEL
NUTS:	<b>B</b>	BRASS

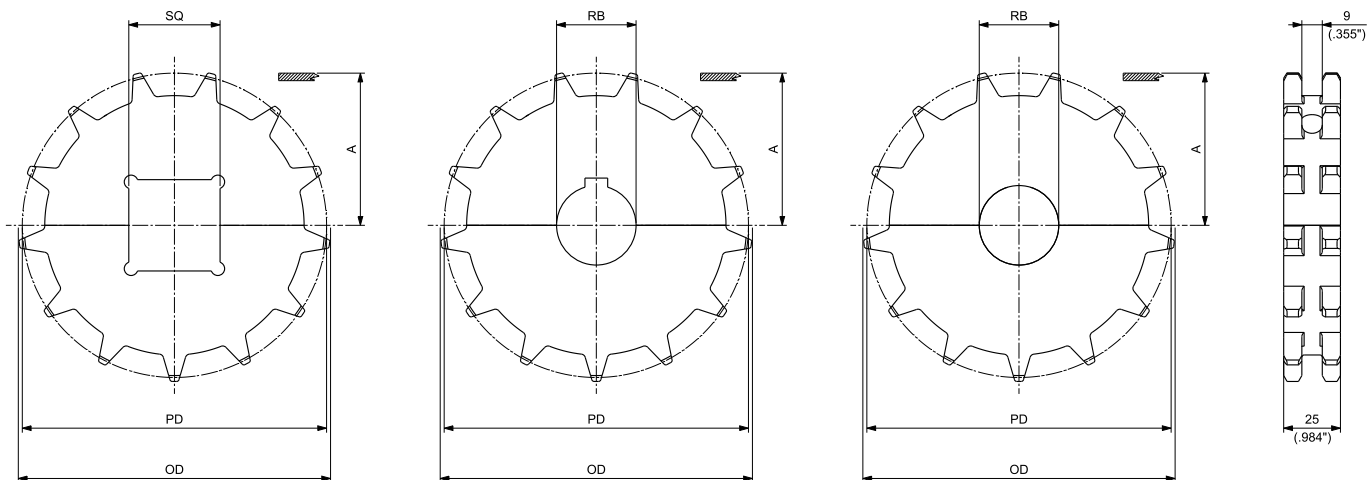

ROUND BORE - DRIVE

ROUND BORE - IDLER

SQUARE BORE - DRIVE/IDLER

## MACHINED DOUBLE ROW SPLIT DRIVE AND IDLER SPROCKETS

N. TEETH	PITCH DIAMETER		OUTSIDE DIAMETER		WEAR STRIP POSITIONING		BORE SIZE*		SQUARE BORE SQ DRIVE/IDLER	PART NUMBER		WEIGHT	
	PD mm	inch	OD mm	inch	A mm	inch	mm	inch**		DRIVE	IDLER	Kg	lbs
10	102,75	4.045	106,50	4.193	45,03	1.773	30			MPBAST255510D30	MPBASQ255510D30	0,18	0.40
							35			MPBAST255510D35	MPBASQ255510D35	0,17	0.37
							40			MPBAST255510D40	MPBASQ255510D40	0,16	0.35
							1			MPBAST255510D254	MPBASQ255510D254	0,19	0.42
							1¼			MPBAST255510D317	MPBASQ255510D317	0,18	0.40
							1½			MPBAST255510D381	MPBASQ255510D381	0,17	0.37
13	132,67	5.223	137,50	5.413	59,99	2.362	30			MPBAST255513D30	MPBASQ255513D30	0,30	0.66
							35			MPBAST255513D35	MPBASQ255513D35	0,29	0.64
							40			MPBAST255513D40	MPBASQ255513D40	0,28	0.62
							1			MPBAST255513D254	MPBASQ255513D254	0,30	0.67
							1¼			MPBAST255513D317	MPBASQ255513D317	0,30	0.65
							1½			MPBAST255513D381	MPBASQ255513D381	0,29	0.63
15	152,71	6.012	158,00	6.220	70,01	2.756	30			MPBAST255515D30	MPBASQ255515D30	0,41	0.91
							35			MPBAST255515D35	MPBASQ255515D35	0,41	0.89
							40			MPBAST255515D40	MPBASQ255515D40	0,40	0.88
							1			MPBAST255515D254	MPBASQ255515D254	0,42	0.92
							1¼			MPBAST255515D317	MPBASQ255515D317	0,41	0.91
							1½			MPBAST255515D381	MPBASQ255515D381	0,40	0.88
16	162,75	6.407	168,00	6.614	75,03	2.954	30			MPBAST255516D30	MPBASQ255516D30	0,48	1.05
							35			MPBAST255516D35	MPBASQ255516D35	0,47	1.04
							40			MPBAST255516D40	MPBASQ255516D40	0,46	1.02
							1			MPBAST255516D254	MPBASQ255516D254	0,48	1.07
							1¼			MPBAST255516D317	MPBASQ255516D317	0,48	1.05
							1½			MPBAST255516D381	MPBASQ255516D381	0,47	1.03

\*In case of round bore, diameter is indicated. In case of square bore, side of the square is indicated.

\*\*Imperial round bore drive sprockets are supplied with setscrew. Metric round bore drive sprockets are supplied without setscrew.

## SUITABLE FOR CHAINS:

- 2556HTB-SR

## MATERIALS

SPROCKETS: **PA** POLYAMIDE

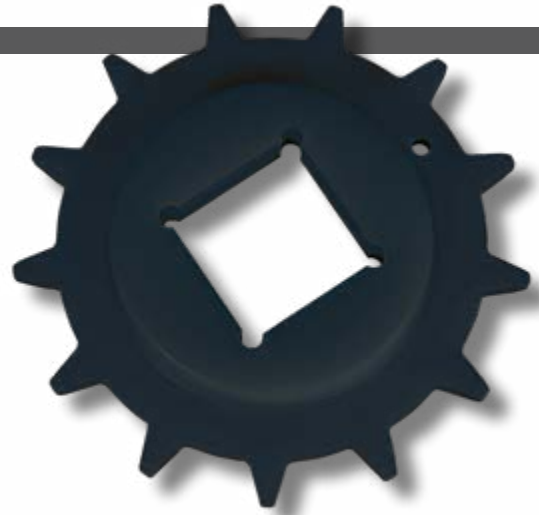

These sprockets are used for 2556HTB-SR belts only.  
One drive and one idler sprocket are needed for each belt regardless of its width.  
For more information on the correct position of these sprockets please contact REGINA Application Engineers.

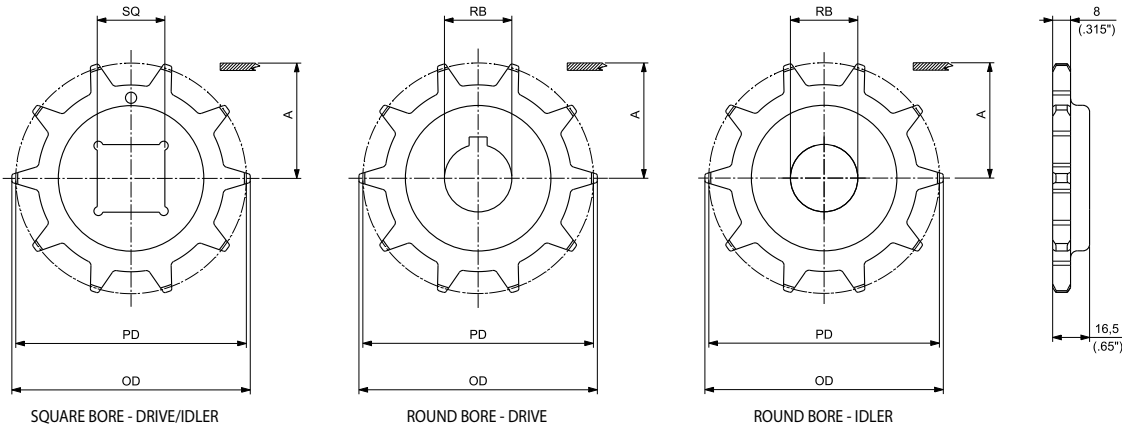

## MACHINED SOLID DRIVE AND IDLER SPROCKETS

N. TEETH	PITCH DIAMETER PD		OUTSIDE DIAMETER OD		WEAR STRIP POSITIONING A		BORE SIZE**		PART NUMBER			WEIGHT	
	mm	inch	mm	inch	mm	inch	mm	inch***	SQUARE BORE SQ DRIVE/IDLER	ROUND BORE RB DRIVE	ROUND BORE RB IDLER	Kg	lbs
8*	82,97	3.267	86,50	3.406	35,14	1.383	35		<b>MPBAT25550830</b>	<b>MPBAF25550830</b>		0,04	0.09
							40		<b>MPBAT25550835</b>	<b>MPBAF25550835</b>		0,03	0.08
							1		<b>MPBAT255508254</b>	<b>MPBAF255508254</b>		0,04	0.10
							1¼		<b>MPBAT255508317</b>	<b>MPBAF255508317</b>		0,04	0.08
10	102,75	4.045	106,50	4.193	45,03	1.773	30		<b>MPBAT25551030</b>	<b>MPBAF25551030</b>		0,08	0.17
							35		<b>MPBAT25551035</b>	<b>MPBAF25551035</b>		0,07	0.16
							40	<b>MPBAQ25551040</b>	<b>MPBAT25551040</b>	<b>MPBAF25551040</b>		0,06	0.14
							1		<b>MPBAT255510254</b>	<b>MPBAF255510254</b>		0,08	0.18
							1¼		<b>MPBAT255510317</b>	<b>MPBAF255510317</b>		0,07	0.16
							1½	<b>MPBAQ255510381</b>	<b>MPBAT255510381</b>	<b>MPBAF255510381</b>		0,07	0.15

\*For some shaft dimensions, shaft needs to be properly machined down to avoid interference with the belt tabs. Please contact REGINA Application Engineering for more details.

\*\*In case of round bore, diameter is indicated. In case of square bore, side of the square is indicated.

\*\*\* Imperial round bore drive sprockets are supplied with setscrew. Metric round bore drive sprockets are supplied without setscrew.



## SUITABLE FOR CHAINS:

- 2556HTB-SR

### MATERIALS

SPROCKETS: **PA** POLYAMIDE

SCREWS: **SS** STAINLESS STEEL

NUTS: **B** BRASS

These sprockets are used for 2556HTB-SR belts only.  
One drive and one idler sprocket are needed for each belt regardless of its width.  
For more information on the correct position of these sprockets please contact REGINA Application Engineers.

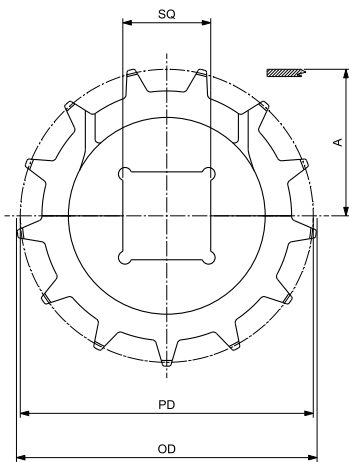
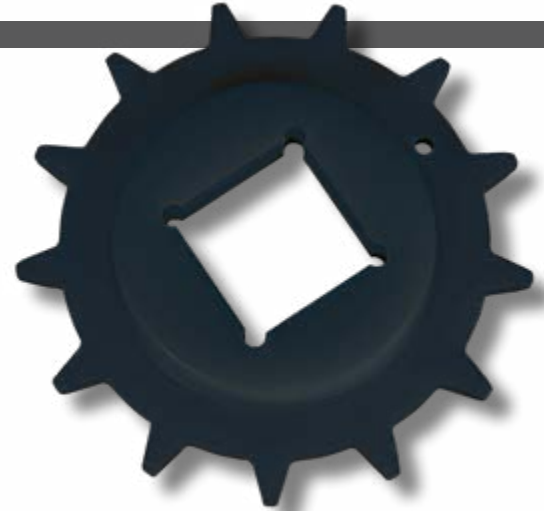

SQUARE BORE - DRIVE/IDLER

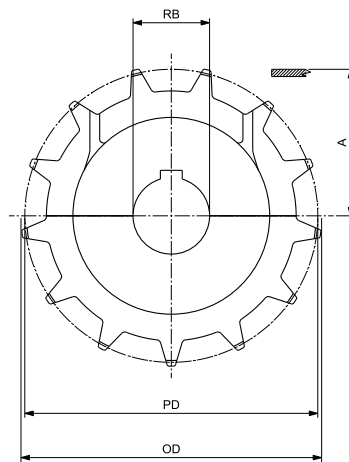

ROUND BORE - DRIVE

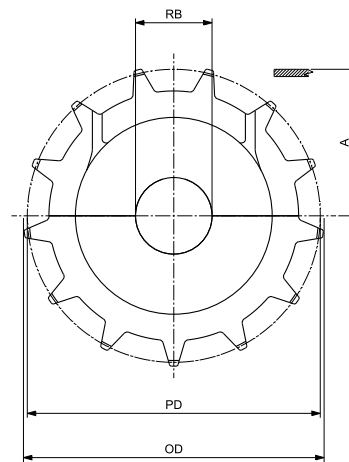

ROUND BORE - IDLER

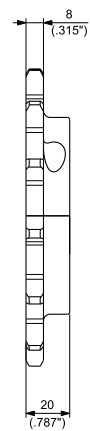

## MACHINED SPLIT DRIVE AND IDLER SPROCKETS

N. TEETH	PITCH DIAMETER PD		OUTSIDE DIAMETER OD		WEAR STRIP POSITIONING A		BORE SIZE*	PART NUMBER			WEIGHT	
	mm	inch	mm	inch	mm	inch		SQUARE BORE SQ DRIVE/IDLER	ROUND BORE RB DRIVE	ROUND BORE RB IDLER	Kg	lbs
10	102,75	4.045	106,50	4.193	45,03	1.773	30	MPBAST25551030	MPBASQ25551030	MPBASQ25551030	0,11	0.24
							35	MPBAST25551035	MPBASQ25551035	0,10	0.22	
							1	MPBAST255510254	MPBASQ255510254	0,12	0.26	
							1¼	MPBAST255510317	MPBASQ255510317	0,11	0.24	
13	132,67	5.223	137,50	5.413	59,99	2.362	30	MPBAST25551330	MPBASQ25551330	MPBASQ25551330	0,20	0.43
							35	MPBAST25551335	MPBASQ25551335	0,19	0.42	
							40	MPBAST25551340	MPBASQ25551340	MPBASQ25551340	0,18	0.40
							1	MPBAST255513254	MPBASQ255513254	0,20	0.44	
							1¼	MPBAST255513317	MPBASQ255513317	0,19	0.43	
							1½	MPBAST255513381	MPBASQ255513381	MPBASQ255513381	0,19	0.41
15	152,71	6.012	158,00	6.220	70,01	2.756	30	MPBAST25551530	MPBASQ25551530	MPBASQ25551530	0,26	0.58
							35	MPBAST25551535	MPBASQ25551535	0,26	0.57	
							40	MPBAST25551540	MPBASQ25551540	MPBASQ25551540	0,25	0.56
							1	MPBAST255515254	MPBASQ255515254	0,27	0.59	
							1¼	MPBAST255515317	MPBASQ255515317	0,26	0.58	
							1½	MPBAST255515381	MPBASQ255515381	MPBASQ255515381	0,25	0.56
16	162,75	6.407	168,00	6.614	75,03	2.954	30	MPBAST25551630	MPBASQ25551630	MPBASQ25551630	0,29	0.63
							35	MPBAST25551635	MPBASQ25551635	0,28	0.62	
							40	MPBAST25551640	MPBASQ25551640	MPBASQ25551640	0,27	0.60
							1	MPBAST255516254	MPBASQ255516254	0,29	0.64	
							1¼	MPBAST255516317	MPBASQ255516317	0,28	0.63	
							1½	MPBAST255516381	MPBASQ255516381	MPBASQ255516381	0,28	0.61

\*In case of round bore, diameter is indicated. In case of square bore, side of the square is indicated.

\*\* Imperial round bore drive sprockets are supplied with setscrew. Metric round bore drive sprockets are supplied without setscrew.

## SUITABLE FOR CHAINS:

• 2556HTB-SR

### MATERIALS

SPROCKETS: **PA** POLYAMIDE

SCREWS: **SS** STAINLESS STEEL

INSERTS: **B** BRASS



These supporting wheels are used for 2556HTB-SR belts only in order to support the inner module. Two supporting wheels are needed (for drive and idler shaft) for each belt regardless of its width. For more information on the correct position of these sprockets please contact REGINA Application Engineers.

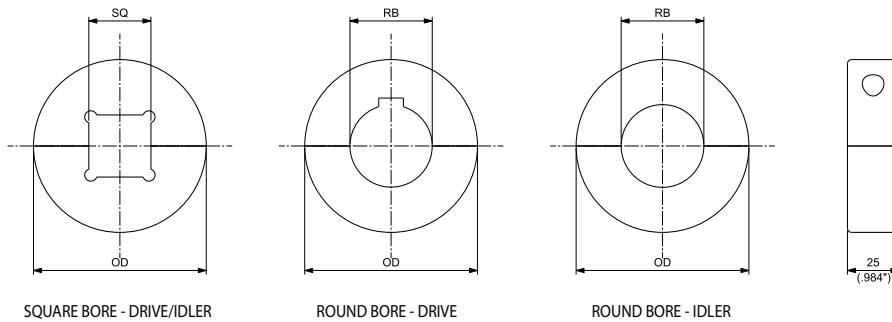

## MACHINED SPLIT SUPPORTING WHEELS

N. TEETH	OUTSIDE DIAMETER OD		BORE SIZE*		PART NUMBER				WEIGHT	
	mm	inch	mm	inch	SQUARE BORE SQ		ROUND BORE RB		Kg	lbs
					DRIVE/IDLER	DRIVE	DRIVE	IDLER		
8	63	2.480	30			<b>CC255001</b>		<b>CC255029</b>	0,08	0.18
			35			<b>CC255002</b>		<b>CC255030</b>	0,07	0.16
			1			<b>CC255003</b>		<b>CC255031</b>	0,09	0.19
			1 1/4			<b>CC255004</b>		<b>CC255032</b>	0,08	0.17
10	84	3.307	30			<b>CC255005</b>		<b>CC255033</b>	0,16	0.35
			35			<b>CC255006</b>		<b>CC255034</b>	0,15	0.34
			40		<b>CC255057</b>	<b>CC255007</b>		<b>CC255035</b>	0,14	0.32
			1			<b>CC255008</b>		<b>CC255036</b>	0,17	0.37
			1 1/4			<b>CC255009</b>		<b>CC255037</b>	0,16	0.35
			1 1/2		<b>CC255058</b>	<b>CC255010</b>		<b>CC255038</b>	0,15	0.33
13	115	4.528	30			<b>CC255011</b>		<b>CC255039</b>	0,30	0.66
			35			<b>CC255012</b>		<b>CC255040</b>	0,29	0.64
			40		<b>CC255059</b>	<b>CC255013</b>		<b>CC255041</b>	0,28	0.62
			1			<b>CC255014</b>		<b>CC255042</b>	0,30	0.67
			1 1/4			<b>CC255015</b>		<b>CC255043</b>	0,30	0.65
			1 1/2		<b>CC255060</b>	<b>CC255016</b>		<b>CC255044</b>	0,29	0.63
15	135	5.315	30			<b>CC255017</b>		<b>CC255045</b>	0,41	0.91
			35			<b>CC255018</b>		<b>CC255046</b>	0,41	0.89
			40		<b>CC255061</b>	<b>CC255019</b>		<b>CC255047</b>	0,40	0.88
			1			<b>CC255020</b>		<b>CC255048</b>	0,42	0.92
			1 1/4			<b>CC255021</b>		<b>CC255049</b>	0,41	0.91
			1 1/2		<b>CC255062</b>	<b>CC255022</b>		<b>CC255050</b>	0,40	0.88
16	145	5.709	30			<b>CC255023</b>		<b>CC255051</b>	0,48	1.05
			35			<b>CC255024</b>		<b>CC255052</b>	0,47	1.03
			40		<b>CC255063</b>	<b>CC255025</b>		<b>CC255053</b>	0,46	1.01
			1			<b>CC255026</b>		<b>CC255054</b>	0,48	1.06
			1 1/4			<b>CC255027</b>		<b>CC255055</b>	0,47	1.04
			1 1/2		<b>CC255064</b>	<b>CC255028</b>		<b>CC255056</b>	0,46	1.02

\*In case of round bore, diameter is indicated. In case of square bore, side of the square is indicated.



PERFORMANCE IN MOTION

# Matveyor<sup>®</sup>

## 2" Pitch Heavy Duty Raised Rib Belts



## INDUSTRIES AND APPLICATIONS

Suitable for handling mainly loose products, such as plastic and glass bottles, aluminium & steel cans, in heavy duty applications.

### INDUSTRIES

Bottling and canning  
Food filling  
Container manufacturing

### APPLICATIONS

Pasteurizers  
Warmers  
Coolers  
Accumulation tables

## FEATURES

- Optimized ratio rib thickness/ribs spacing and special clips design guarantee uniform top surface and high support of the most unstable products such as PET bottles with petaloid bottom.
- Optimum combination open area / mechanical strength allows very good liquid drainage and high product load with long center to center distances.
- Clips integrated in the modules for seamless product support at the edges of the belt.
- Contrasting colour of the integrated clip makes it easy to identify the clip itself for safer working conditions.

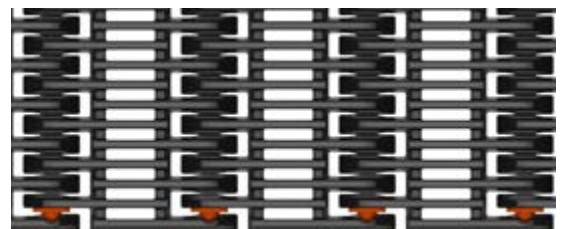

## BELT ASSEMBLY



1) In order to link two belt sections, push the pin in.

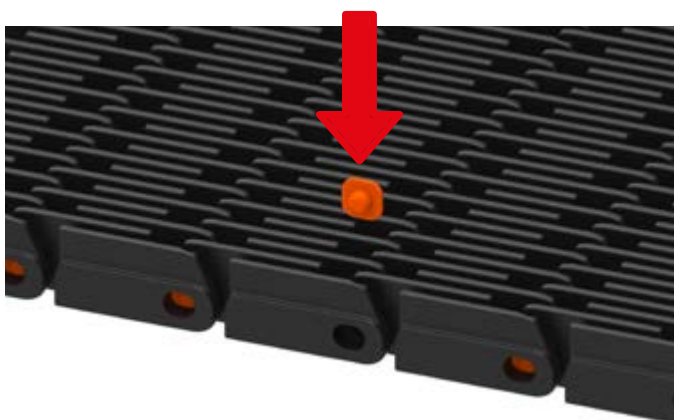

2) Insert the clip into the belt pocket securing it with the help of a screwdriver.

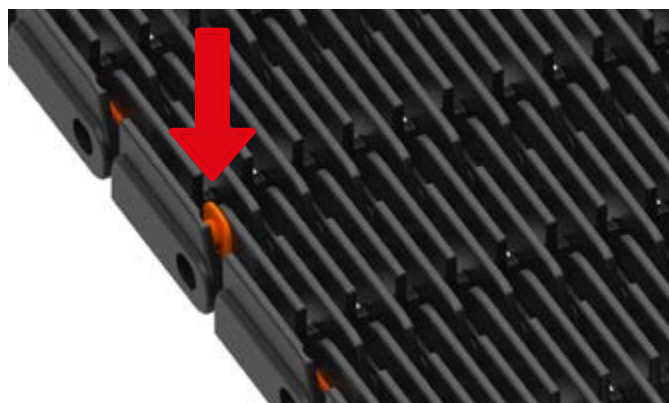

## BELT DISASSEMBLY

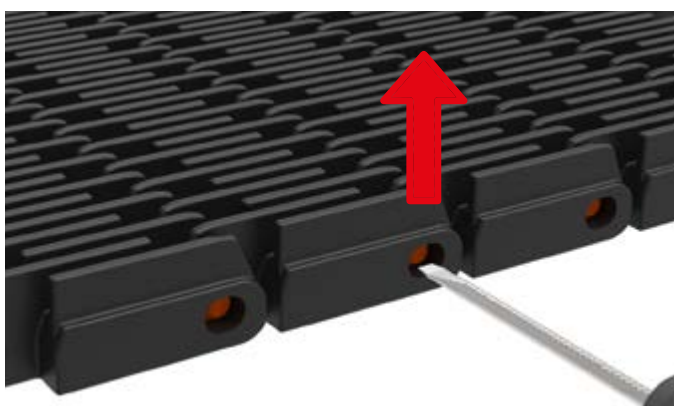

1) Insert a screwdriver into the side hole of the belt and lift the clip.

2) Repeat the same operations on the other side of the belt and then push the plastic pin out using the screwdriver.

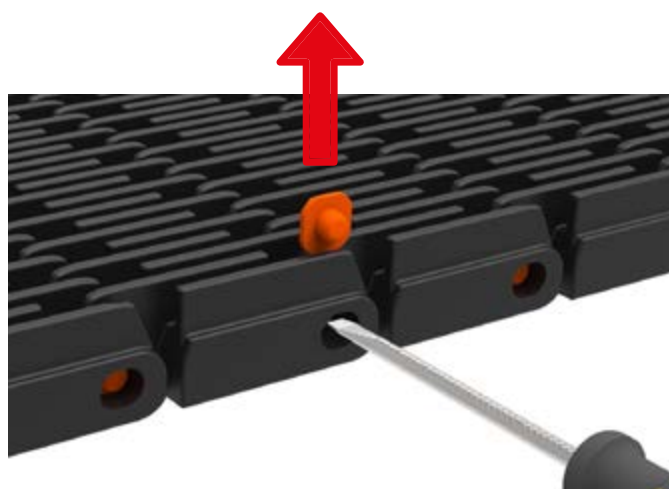

**14,2 mm (0.580") THICKNESS**  
**RAISED RIB**  
**SEAMLESS PRODUCT SUPPORT AT THE EDGES OF THE BELT**

**NEW**



3125 belt is ideal for pasteurizer applications where the most unstable products such as PET bottles with petaloid bottom have to be conveyed. The raised rib surface shows no discontinuity between modules both along the belt width and the belt travel direction, allowing containers to slide across easily without the risk of product tippage throughout the tunnel pasteurizer.

- **Belt widths:** 304,8 mm (12") or wider in 76,2 mm (3") increments
- **Working Load (at 25°C/77°F):** 24670 N/m (1690 lbs/ft)
- **Belt weight:** 10,76 kg/m<sup>2</sup> (2.20 lbs/ft<sup>2</sup>)

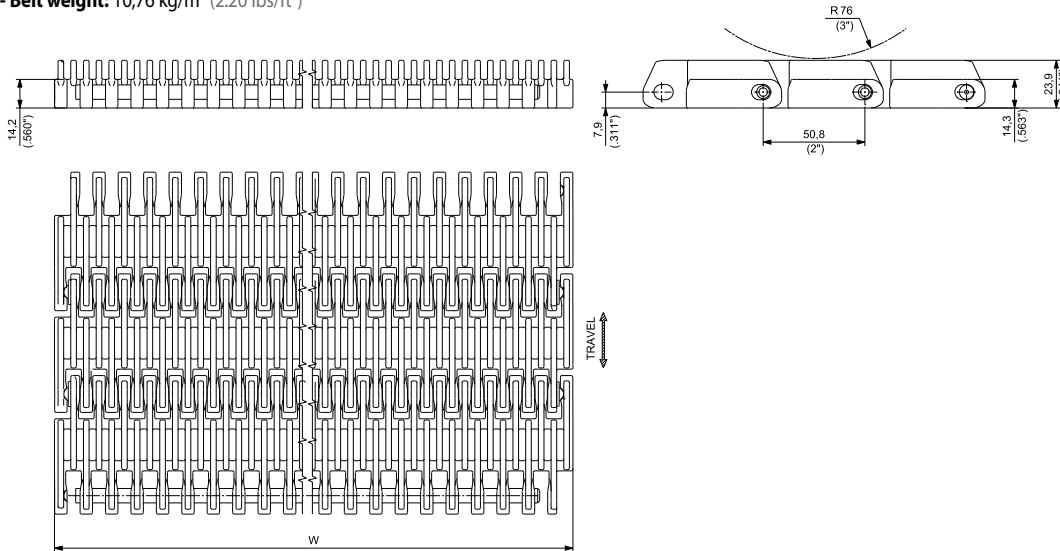

Materials  
see page 12



Combs  
see pages 266÷267



Sprockets  
see pages 268÷269



Applications  
see page 22

WIDTH W		MATERIALS	
		Module	Pin
		PP	SPECIAL POLYPROPYLENE
		PART NUMBER	
mm	inch		
304,8	12		<b>3125PP012</b>
381,0	15		<b>3125PP015</b>
457,2	18		<b>3125PP018</b>
533,4	21		<b>3125PP021</b>
609,6	24		<b>3125PP024</b>
685,8	27		<b>3125PP027</b>
762,0	30		<b>3125PP030</b>
838,2	33		<b>3125PP033</b>
914,4	36		<b>3125PP036</b>
990,6	39		<b>3125PP039</b>
1066,8	42		<b>3125PP042</b>
1143,0	45		<b>3125PP045</b>
1219,2	48		<b>3125PP048</b>
1295,4	51		<b>3125PP051</b>
1371,6	54		<b>3125PP054</b>
1447,8	57		<b>3125PP057</b>
1524,0	60		<b>3125PP060</b>
			POLYPROPYLENE

Belts wider than 1524 mm (60") are available in 76,2 (3") increments.  
 To identify the Part Numbers, please substitute the last three digits of the PN with the desired width.  
 Example: for a 63" wide belt (=60+3 inches), the PN is "3125PP063".  
 On request belts are available in 1.5" (38,1 mm) increments starting from 12" (304,8 mm).  
 To identify the PN, please add letter "M" to the integer number of the desired width.  
 Example: 45+1.5=46,5 inches width, the PN is "3125PP046M".



**Standard packaging:**  
 Belts are supplied in the length requested by the customer.





## TRANSFER COMBS

Combs are supplied complete with slot covers but without fastening screws.  
 Two fastening screws are required for each comb.  
 They can be ordered using P/N 16300005.  
 Special note: the comb fastening screws for 3125 belts are not interchangeable with fastening screws for 1110 belts.

### MATERIALS

COMBS: **DG** ACETAL RESIN

SCREWS\*: **SS** STAINLESS STEEL

\*Screws are not included in the combs.

LONG FINGER COMB

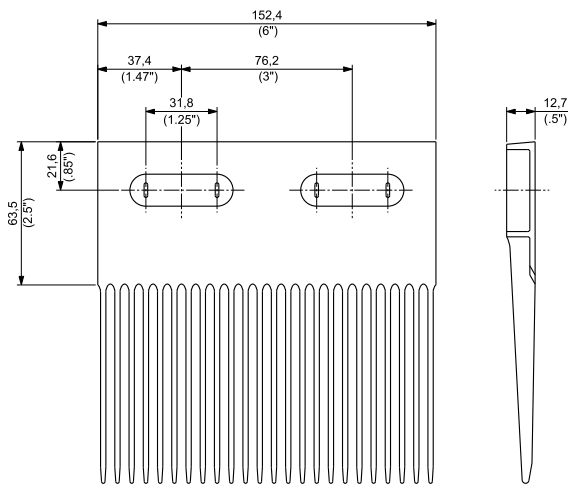

PART NUMBER **TC3000-01**

LONG FINGER COMB

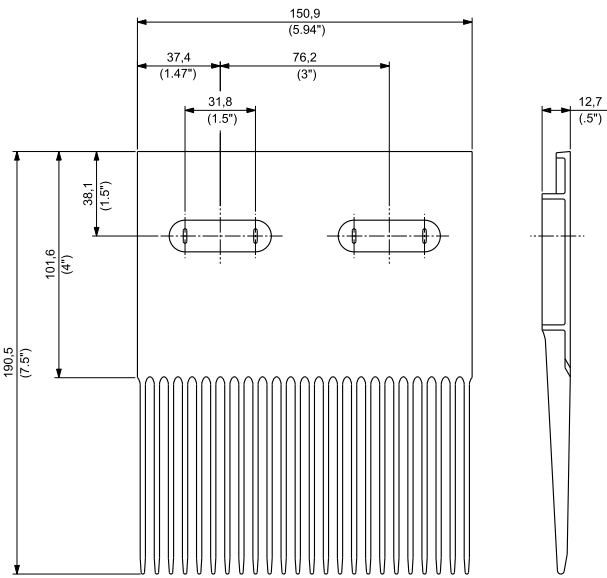

PART NUMBER **TC3000-02**

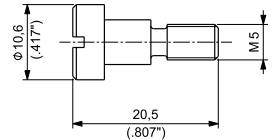

PART NUMBER **16300005**

SHORT FINGER COMB

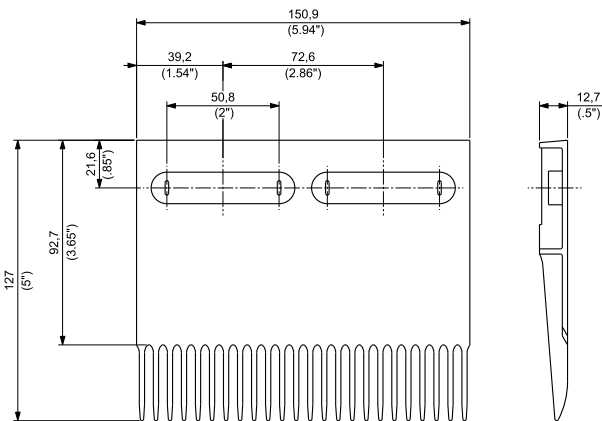

PART NUMBER **TC3000-03**

SHORT FINGER COMB

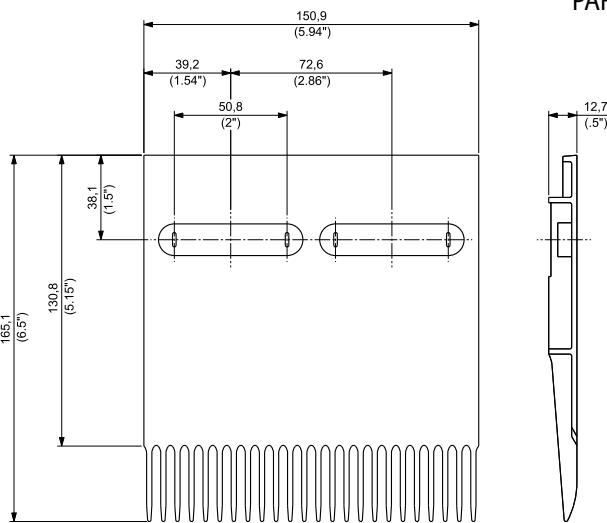

PART NUMBER **TC3000-04**

## TRANSFER COMBS

Combs are supplied complete with slot covers, bushings and fastening screws type hex socket button head  $\frac{1}{4}$ " x  $\frac{5}{8}$ " UNI-ISO 7380.



### MATERIALS

COMBS: **DG** ACETAL RESIN

SCREWS: **SS** STAINLESS STEEL

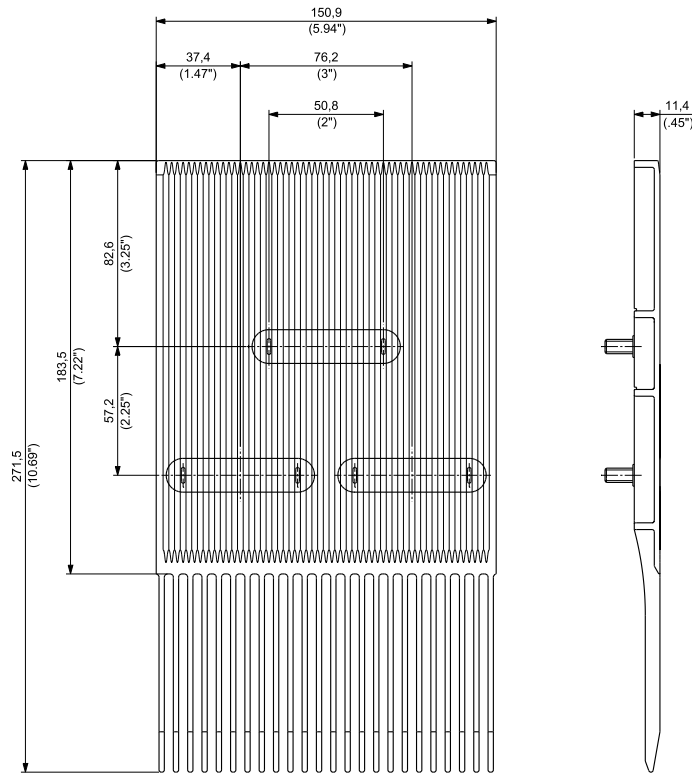

PART NUMBER **TC3000-05**

## SUITABLE FOR CHAINS:

• 3125

## MATERIALS

SPROCKETS: WA ACETAL RESIN

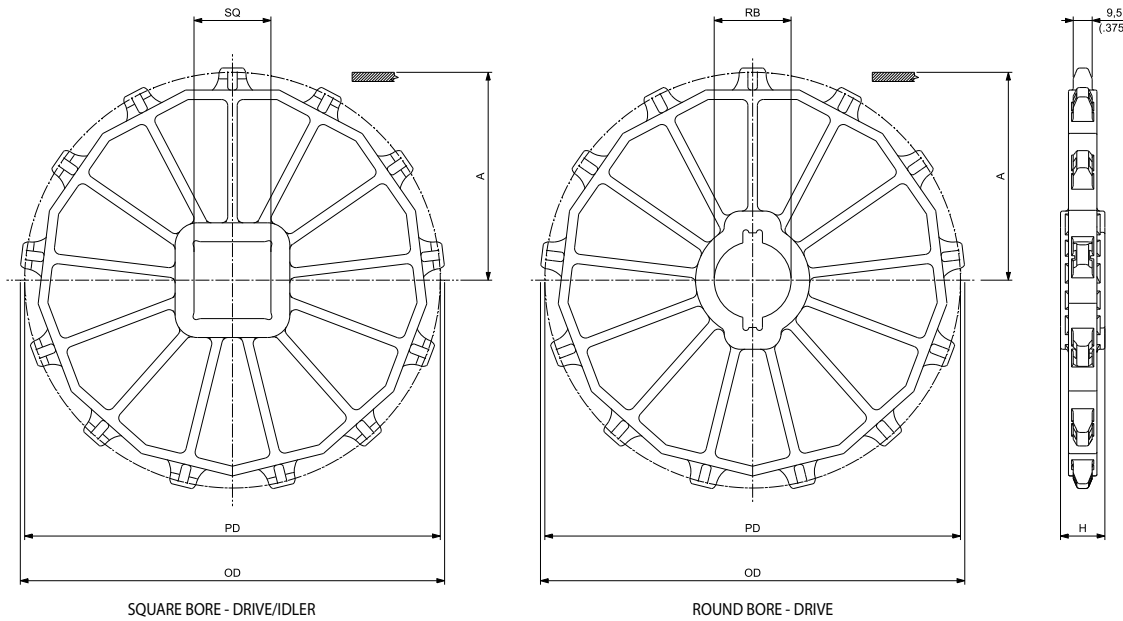

SQUARE BORE - DRIVE/IDLER

ROUND BORE - DRIVE

## MOULDED SOLID DRIVE AND IDLER SPROCKETS

N. TEETH	PITCH DIAMETER PD		OUTSIDE DIAMETER OD		WEAR STRIP POSITIONING A		BORE SIZE*		PART NUMBER		HUB WIDTH H		WEIGHT	
	mm	inch	mm	inch	mm	inch	mm	inch	SQ BORE DRIVE/IDLER	ROUND BORE RB DRIVE	mm	inch	Kg	lbs
10	164,39	6.472	162,60	6.402	74,30	2.925	40		<b>19200026</b>	<b>19200038</b>	22,20	0.874	0,20	0.44
							50			<b>19200036</b>	22,20	0.874	0,21	0.46
							60		<b>19200024</b>		47,60	1.874	0,29	0.64
							65		<b>19200027</b>		47,60	1.874	0,25	0.55
							1½		<b>19200016</b>	<b>19200009</b>	22,20	0.874	0,19	0.43
							2		<b>19200017</b>	<b>19200010</b>	22,20	0.874	0,23	0.51
13	212,27	8.357	212,30	8.358	98,20	3.866	40		<b>19200025</b>		22,20	0.874	0,33	0.74
							60		<b>19200037</b>		47,60	1.874	0,44	0.97
							65			<b>19200033</b>	22,20	0.874	0,32	0.71
							65		<b>19200030</b>	<b>19200053</b>	47,60	1.874	0,39	0.86
							90		<b>19200031</b>	<b>19200045</b>	47,60	1.874	0,41	0.91
							1½		<b>19200019</b>	<b>19200001</b>	47,60	1.874	0,34	0.75
							2½			<b>19200011</b>	22,20	0.874	0,41	0.90
							2½		<b>19200020</b>		47,60	1.874	0,45	0.99
16	260,40	10.252	261,60	10.299	112,30	4.421	65		<b>19200034</b>		47,60	1.874	0,50	1.11
							90		<b>19200035</b>	<b>19200054</b>	47,60	1.874	0,54	1.19
							120		<b>19200038</b>		47,60	1.874	0,52	1.15
							2½		<b>19200014</b>	<b>19200050</b>	47,60	1.874	0,52	1.15
							3½		<b>19200015</b>	<b>19200051</b>	47,60	1.874	0,54	1.19

\*In case of round bore, diameter is indicated. In case of square bore, side of the square is indicated.

## SUITABLE FOR CHAINS:

• 3125

### MATERIALS

SPROCKETS: **WA** ACETAL RESIN

SCREWS: **SS** STAINLESS STEEL

NUTS: **SS** STAINLESS STEEL

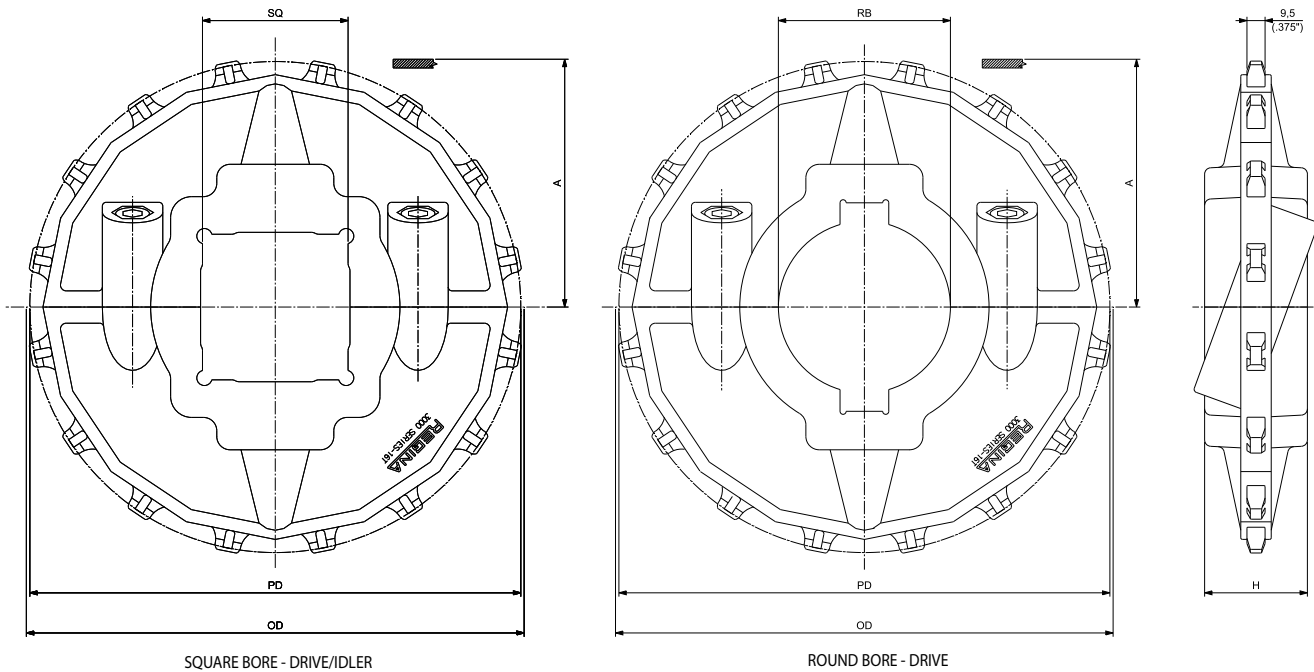

### MOULDED SPLIT DRIVE AND IDLER SPROCKETS

N. TEETH	PITCH DIAMETER PD		OUTSIDE DIAMETER OD		WEAR STRIP POSITIONING A		BORE SIZE*	PART NUMBER		HUB WIDTH H		WEIGHT	
	mm	inch	mm	inch	mm	inch		SQUARE BORE SQ	ROUND BORE RB	mm	inch	Kg	lbs
								DRIVE/IDLER	DRIVE				
16	260,40	10.252	261,40	10.291	112,30	4.421	65	<b>19200111W</b>	<b>19200109W</b>	54,00	2.126	1,85	4.08
							90	<b>19200114W</b>	<b>19200112W</b>	54,00	2.126	1,56	3.44
							2½	<b>19200105W</b>	<b>19200103W</b>	54,00	2.126	1,86	4.10
							3½	<b>19200108W</b>	<b>19200106W</b>	54,00	2.126	1,57	3.45

\*In case of round bore, diameter is indicated. In case of square bore, side of the square is indicated.



PERFORMANCE IN MOTION

**ULTOP<sup>®</sup>**

**1 1/2" Pitch Heavy Duty  
UCC Chains**

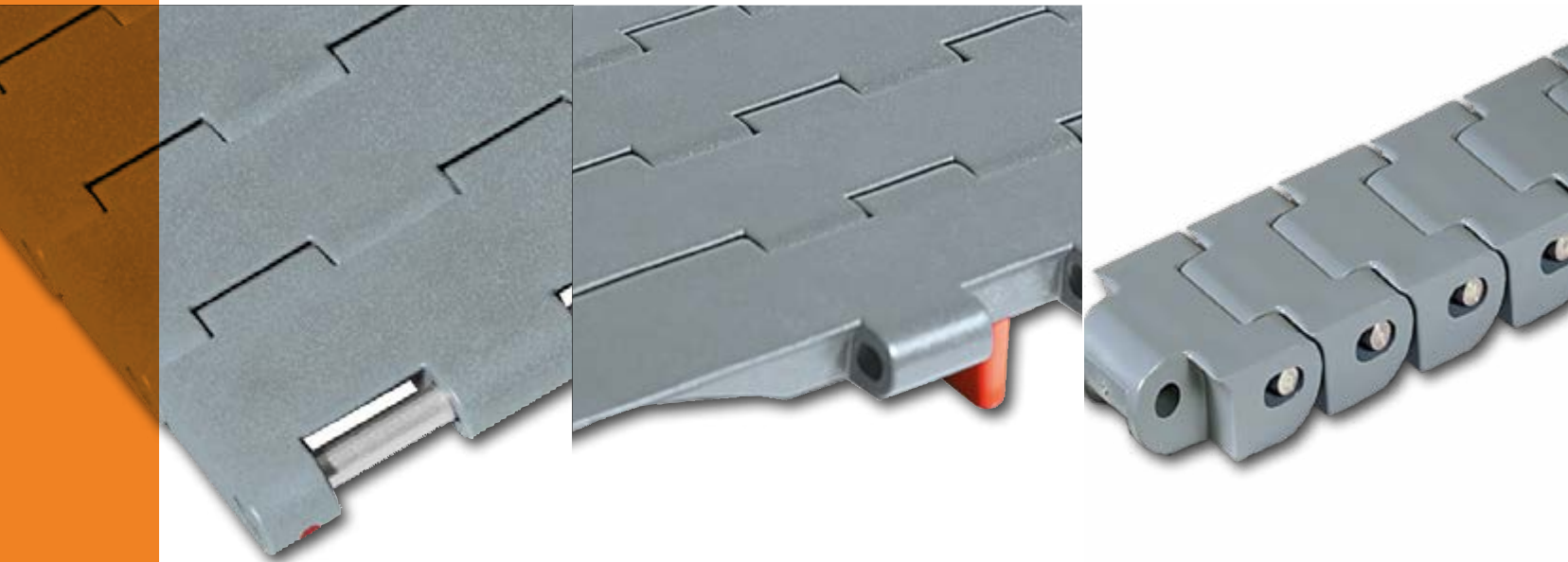

## INDUSTRIES AND APPLICATIONS

Suitable for handling loose & packaged products, such as plastic & glass bottles and aluminium & steel cans, in heavy duty applications.

### INDUSTRIES

Bottling and canning  
 Food filling  
 Container manufacturing  
 (in particular glass bottles)  
 Consumer goods

### APPLICATIONS

Depalletizer  
 Pressureless Inliners and Combiners  
 Single lane and Mass conveyors  
 Case conveyors



## FEATURES

- Optimized edge profile combined with completely closed surface, with no gaps even when engaging the sprockets, allow smooth side transfer of products, even in presence of different thicknesses due to normal wear.



- Chains equipped with stainless steel pins for the maximum mechanical and wear resistance.



- Retention special clip (Snapsert™) can be easily moved from either side allowing easy chain assembly and disassembly.





### 12,7 mm (0.5") THICKNESS SOLID TOP

Stainless steel pins for ideal performance in heavy duty applications.  
A complete range of dedicated width chains. Completely closed surface, no gap between the modules, even with engaging in the sprockets. Particularily suitable for glass bottling lines and glass manufacturing industry.

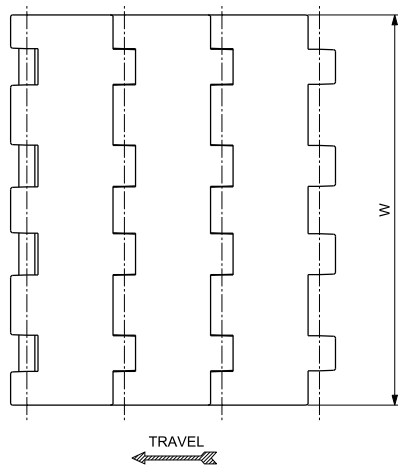

Materials  
see page 12



Sprockets  
see page 275



Applications  
see page 22

MATERIALS		ITEM DESCRIPTION	PART NUMBER	WIDTH W		PLATE THICKNESS		WORKING LOAD (25°C/77°F)		WEIGHT	
Plate	Pin			mm	inch	mm	inch	N	lbs	kg/m	lbs/ft
ULTRA LOW FRICTION POLYESTER RESIN <b>ULF</b>		UCC 325 SS	<b>66100111</b>	82,6	3.25	12,7	0.5	2505	563	1,26	0.85
		UCC 450 SS	<b>66100141</b>	114,3	4.50	12,7	0.5	3469	780	1,74	1.17
		UCC 600 SS	<b>66100161</b>	152,4	6.00	12,7	0.5	4625	1040	2,32	1.56
		UCC 750 SS	<b>66100151</b>	190,5	7.50	12,7	0.5	5781	1300	2,93	1.97
		UCC 1200 SS	<b>66100191</b>	304,8	12.00	12,7	0.5	9270	2061	4,64	3.12
		UCC 1500 SS	<b>66100181</b>	381,0	15.00	12,7	0.5	11590	2605	5,81	3.90
		UCC 1800 SS	<b>66100221</b>	457,2	18.00	12,7	0.5	13900	3125	6,97	4.69
		UCC 2400 SS	<b>66100231</b>	609,6	24.00	12,7	0.5	18540	4168	9,27	6.23
	AUSTENITIC STAINLESS STEEL	D2K UCC 325 SS	<b>D2K66100111</b>	82,6	3.25	12,7	0.5	2505	563	1,33	0.89
		D2K UCC 450 SS	<b>D2K66100141</b>	114,3	4.50	12,7	0.5	3469	780	1,83	1.23
		D2K UCC 600 SS	<b>D2K66100161</b>	152,4	6.00	12,7	0.5	4625	1040	2,43	1.64
	SPECIAL DELRIN® REINFORCED WITH KEVLAR® <b>DK2</b>	D2K UCC 750 SS	<b>D2K66100151</b>	190,5	7.50	12,7	0.5	5781	1300	3,07	2.06
		D2K UCC 1200 SS	<b>D2K66100191</b>	304,8	12.00	12,7	0.5	9270	2061	4,88	3.28
		D2K UCC 1500 SS	<b>D2K66100181</b>	381,0	15.00	12,7	0.5	11590	2605	6,10	4.10
		D2K UCC 1800 SS	<b>D2K66100221</b>	457,2	18.00	12,7	0.5	13900	3125	7,32	4.92
		D2K UCC 2400 SS	<b>D2K66100231</b>	609,6	24.00	12,7	0.5	18540	4168	9,73	6.54



Standard packaging:  
Rolls of 3,048 m (10 feet)

### ACTIVE TRANSFER MODULES 12,7 mm (0.5") THICKNESS SOLID TOP

Active transfer modules UCCG ATM allow transfer of products between two 90° conveyor tracks without using dead plaers. The special wing shaped module profile supports the products dynamically during transfer on the take-away belt.

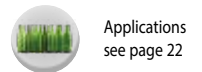
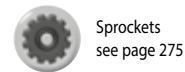
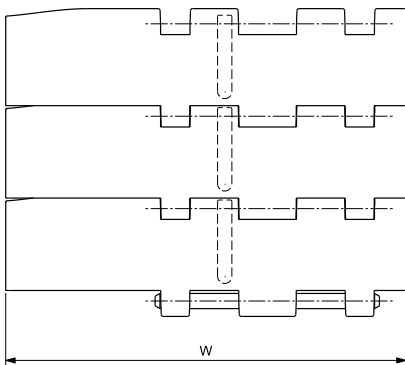
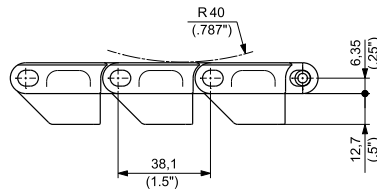
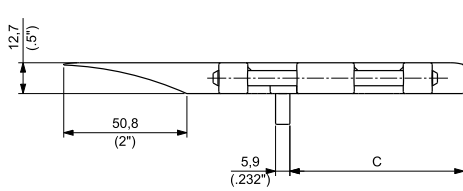

MATERIALS		ITEM DESCRIPTION	PART NUMBER	WIDTH W		PLATE THICKNESS		TRACKING GUIDE POSITION		WORKING LOAD (25°C/77°F)		WEIGHT	
Plate	Pin			mm	inch	mm	inch	mm <sup>C</sup>	inch	N	lbs	kg/m	lbs/ft
ULF ULTRA LOW FRICTION POLYESTER RESIN	AUSTENITIC STAINLESS STEEL	UCCGATM 450 SS	66100331	165,1	6.50	12,7	0.5	71,4	2.81	3469	780	2,11	1.41
		UCCGATM 750 SS	66100341	241,3	9.50	12,7	0.5	139,5	5.49	5781	1.300	3,26	2.19
SPECIAL DELRIN® REINFORCED WITH KEVLAR® DK2™	AUSTENITIC STAINLESS STEEL	UCCGATM D2K 450 SS	D2K66100331	165,1	6.50	12,7	0.5	71,4	2.81	3469	780	2,22	1.49
		UCCGATM D2K 750 SS	D2K66100341	241,3	9.50	12,7	0.5	139,5	5.49	5781	780	3,43	2.31

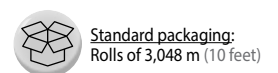

### 15 mm (0.591") THICKNESS SOLID TOP

Optimum support of the conveyed products, no risk for flight detachment (compared to two piece chains).  
No gap between the plates even when engaging the sprockets.  
Particularly suitable for packaging machines applications.

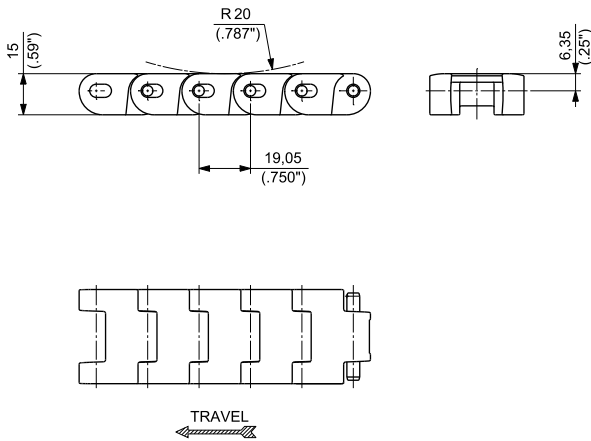

ULTOP

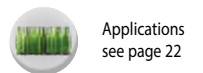
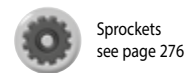

MATERIALS		ITEM DESCRIPTION	PART NUMBER	WIDTH W		PLATE THICKNESS		WORKING LOAD (25°C/77°F)		WEIGHT	
Plate	Pin			mm	inch	mm	inch	N	lbs	kg/m	lbs/ft
ULTRA LOW FRICTION POLYESTER RESIN <b>ULF</b>	AUSTENITIC STAINLESS STEEL	UCC 138 SS	66100321	34,92	1.37	15	0.591	1225	275	0,68	0.46

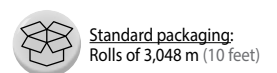

## SUITABLE FOR CHAINS:

- UCC

### MATERIALS

SPROCKETS:	<b>PGF</b>	REINFORCED POLYAMIDE
SCREW:	<b>SS</b>	STAINLESS STEEL
NUTS:	<b>S+ZN</b>	ZINC PLATED STEEL

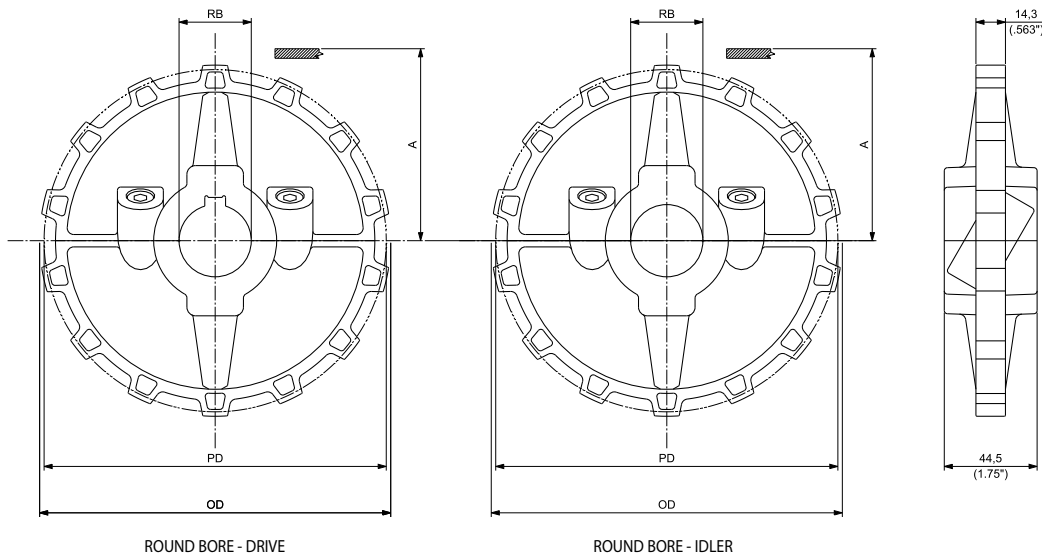

## MOULDED SPLIT DRIVE AND IDLER SPROCKETS

N. TEETH	PITCH DIAMETER PD		OUTSIDE DIAMETER OD		WEAR STRIP POSITIONING A		BORE SIZE*		PART NUMBER ROUND BORE RB		WEIGHT	
	mm	inch	mm	inch	mm	inch	mm	inch**	DRIVE	IDLER	Kg	lbs
12	147,21	5.796	146,80	5.780	67,30	2.650	30		<b>UCCST1230</b>	<b>UCCSF1230</b>	0,36	0.80
							35		<b>UCCST1235</b>	<b>UCCSF1235</b>	0,35	0.77
							40		<b>UCCST1240</b>	<b>UCCSF1240</b>	0,34	0.75
							1		<b>UCCST12254</b>	<b>UCCSF12254</b>	0,37	0.82
							1 3/16		<b>UCCST12301</b>	<b>UCCSF12301</b>	0,36	0.79
							1 1/4		<b>UCCST12317</b>	<b>UCCSF12317</b>	0,36	0.79
							1 3/8		<b>UCCST12349</b>	<b>UCCSF12349</b>	0,34	0.76
							1 7/16		<b>UCCST12365</b>	<b>UCCSF12365</b>	0,35	0.76
1 1/2		<b>UCCST12381</b>	<b>UCCSF12381</b>	0,34	0.76							
14	171,22	6.741	170,20	6.701	79,30	3.122	30		<b>UCCST1430</b>	<b>UCCSF1430</b>	0,44	0.97
							35		<b>UCCST1435</b>	<b>UCCSF1435</b>	0,43	0.95
							40		<b>UCCST1440</b>	<b>UCCSF1440</b>	0,42	0.92
							1		<b>UCCST14254</b>	<b>UCCSF14254</b>	0,44	0.98
							1 3/16		<b>UCCST14301</b>	<b>UCCSF14301</b>	0,44	0.96
							1 1/4		<b>UCCST14317</b>	<b>UCCSF14317</b>	0,46	1.01
							1 3/8		<b>UCCST14349</b>	<b>UCCSF14349</b>	0,43	0.94
							1 7/16		<b>UCCST14365</b>	<b>UCCSF14365</b>	0,43	0.94
1 1/2		<b>UCCST14381</b>	<b>UCCSF14381</b>	0,43	0.94							

\*Diameter is indicated.

\*\* Imperial round bore drive sprockets are supplied with setscrew. Metric round bore drive sprockets are supplied without setscrew.

## SUITABLE FOR CHAINS:

- UCC138

## MATERIALS

SPROCKETS: **S** CARBON STEEL

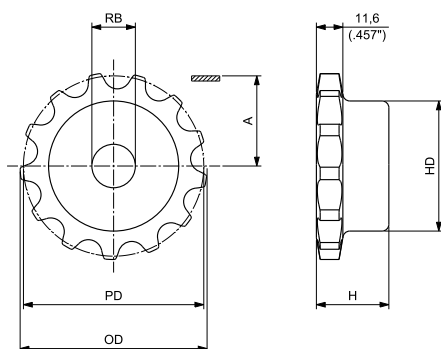

ULTOP

## MACHINED SOLID SPROCKETS

N. TEETH	PITCH DIAMETER PD		OUTSIDE DIAMETER OD		WEAR STRIP POSITIONING A		HD		H		BORE SIZE*		PART NUMBER ROUND BORE RB	WEIGHT	
	mm	inch	mm	inch	mm	inch	mm	inch	mm	inch	mm	inch		Kg	lbs
9	55,70	2.193	56,9	2.24	19,20	0.756	32	1.26	30	1.18	12	0.47	<b>CMA021380900</b>	0,31	0.68
11	67,62	2.662	69,5	2.74	25,15	0.990	45	1.77	35	1.38	14	0.55	<b>CMA021381100</b>	0,57	1.26
13	79,60	3.134	81,9	3.22	31,15	1.226	57	2.24	35	1.38	14	0.55	<b>CMA021381300</b>	0,87	1.92
15	91,63	3.607	94,2	3.71	37,17	1.463	69	2.72	35	1.38	14	0.55	<b>CMA021381500</b>	1,24	2.74
17	103,67	4.081	106,5	4.19	43,19	1.700	80	3.15	35	1.38	16	0.63	<b>CMA021381700</b>	1,63	3.60
19	115,74	4.557	118,8	4.68	49,22	1.938	80	3.15	35	1.38	16	0.63	<b>CMA021381900</b>	1,82	4.01
21	127,82	5.032	131,0	5.16	55,26	2.176	90	3.54	40	1.57	20	0.79	<b>CMA021382100</b>	2,48	5.47
23	139,90	5.508	143,2	5.64	61,30	2.413	90	3.54	40	1.57	20	0.79	<b>CMA021382300</b>	2,71	5.98
25	152,00	5.984	155,4	6.12	67,35	2.652	90	3.54	40	1.57	20	0.79	<b>CMA021382500</b>	2,97	6.55

\*Diameter is indicated (plain bore).



PERFORMANCE IN MOTION

# ***FliteTop***® **Matveyor**®

## Magnetic Curves

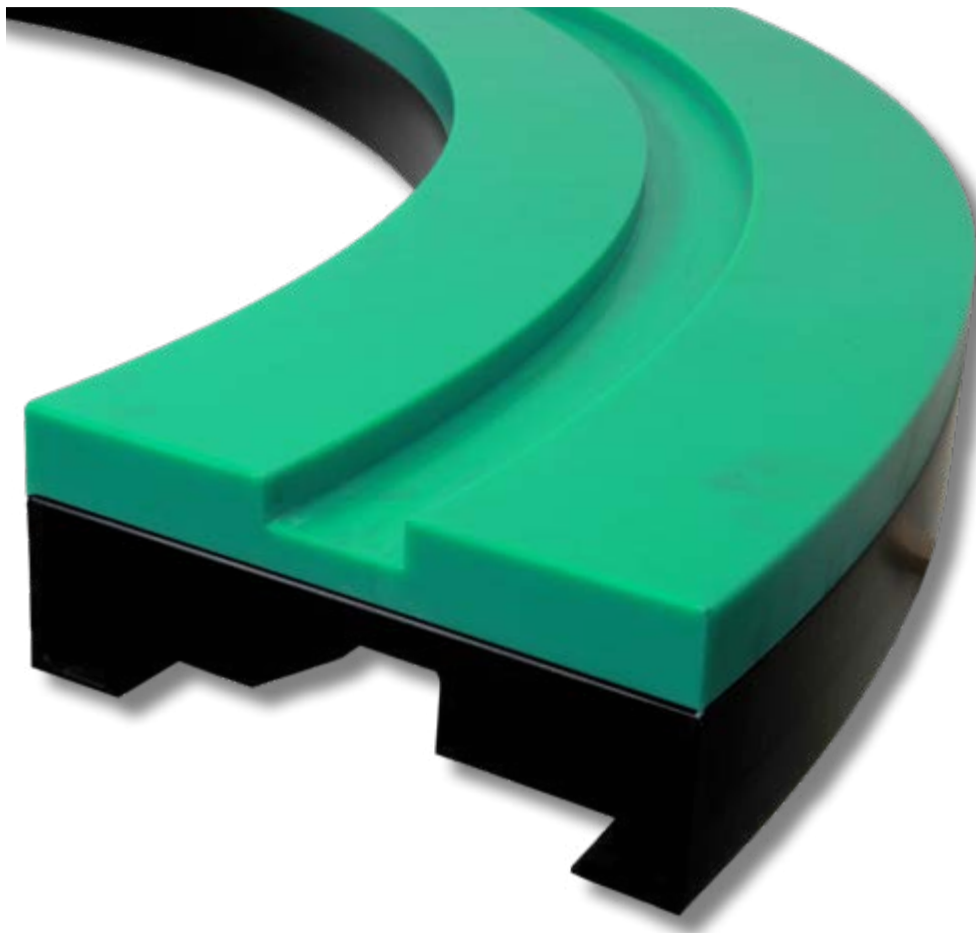



Magnetic curves are a combined system for both steel and plastic chains.

Two magnets, integrated underneath the track and connected by a steel plate, creating a strong magnetic field that results in an even force keeping down steel chains as well as plastic chains with steel pins running in the curve.

The position of the magnets has been carefully studied in order to get the ideal distribution of the magnetic field, with the following results:

- No chain pulsation effect when the chain is being pulled through the curve.
- Chains perfectly flat in curve without tilting



The REGINA magnetic curve consists of mainly N. 3 parts:

- 1 Machined upper plastic part of the curve, normally supplied with the standard SUPREME-A material which is a virgin UHMWPE (about 7 millions gr/mole) with an optimum wear resistance.
- 2 Machined return part of the curve, supplied in UHMWPE material with 4 millions gr/mole which is suitable even for the most demanding applications. This part is jointed to the upper part by stainless steel self-tapping screws.
- 3 Return guide shoe, made in UHMWPE material with 4 millions gr/mole, to bring the chain at the right height to enter the return part of the curve.

For special applications involving very high speeds and reduced lubrication conditions SUPREME-L and SUPREME-S materials can be used to guarantee higher PV (Pressure-Velocity) loads according to the application needs (please see the table and the "PV LIMIT" graph below).

CURVE MATERIAL	FEATURES	CHAIN TYPE	APPLICATIONS
 STANDARD MATERIAL	Ultra high molecular weight polyethylene (about 7 million gr/mole) with good wear resistance and low coefficient of friction.	For steel and plastic chains.	Ideal in low/medium speed applications in dry or lubricated conditions.
	Ultra high molecular weight polyethylene (about 7-9 million gr/mole) with optimum wear and abrasion resistance combined with advanced lubricant for excellent gliding properties.	For steel and plastic chains.	Suitable in medium/high speed applications in dry or reduced lubricated conditions.
	Special high grade and oil-filled polyamide with superior abrasion resistance and extremely high PV limit. Dry running only.	For plastic chains.	Suitable in high speed applications in dry running conditions.

### PV LIMIT

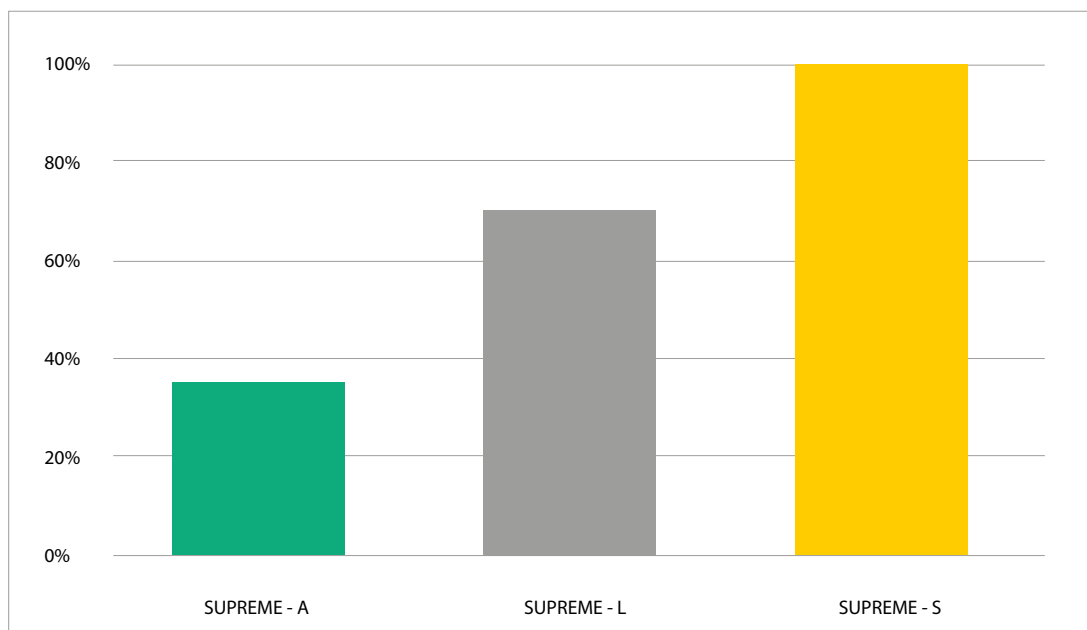

Test condition: 70 m/min chain speed, dry running

## SUPPLY INFORMATIONS

REGINA magnetic curves are supplied as follow:

- The upper and return part are connected by stainless steel self-tapping screws  $\varnothing 4$  mm.
- All of REGINA curves are supplied with the return guide shoe equipped with N.4 brass threaded inserts M8 already assembled.

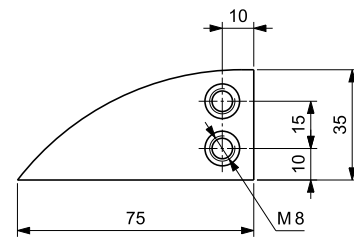
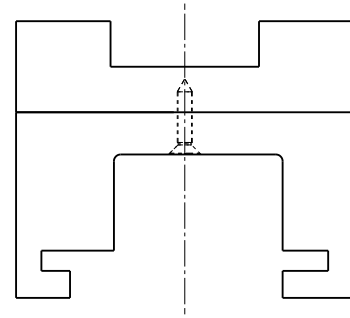

## INSTALLATION OF THE MAGNETIC CURVES

REGINA magnetic curves can be installed on the conveyor in the two following ways:

- 1) Fixing the outer and the inner side of the curve (upper and return part jointed together) to the conveyor frame. In this case the curve is installed with the upper and return part connected as supplied by REGINA and it is fixed to the conveyor making lateral holes on the return part of the curve and using brass threaded inserts M10. These inserts can be **ORDERED SEPARATELY** with the P/N I-SCTBM10 (component **NOT supplied** with the curves).

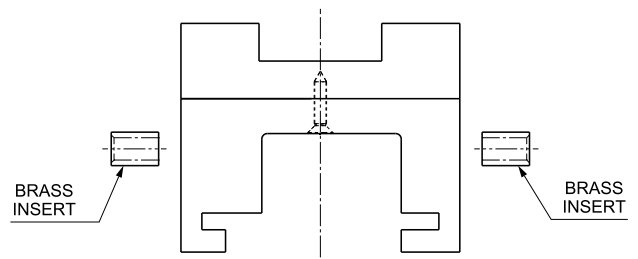

- 2) The upper and return part of the curve can be installed **separately** on the conveyor. In this case the curve, which is supplied with the upper and return part connected with stainless steel self-tapping screws, must be disassembled and fixed to a conveyor crossbar using the holes present on both parts of the curve. The screws to fix the upper and lower part of the curve to the crossbar must have a proper length depending on the conveyor structure. Those screws are **NOT** supplied by REGINA.

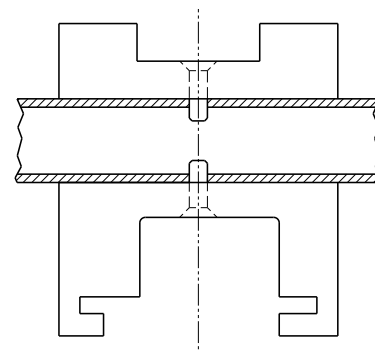

## REFERENCE TABLE

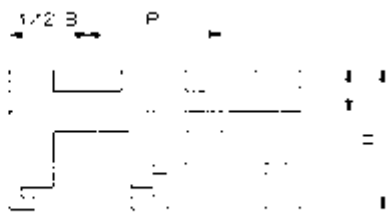
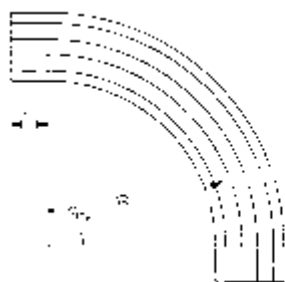

CHAIN TYPE				RADIUS <sup>(1)</sup> R mm	TRANSVERSAL		INFEEED LENGHT L mm	UPPER PART HEIGHT U mm	TOTAL HEIGHT		VERSION NUMBER	SEE PAGE
SERIES	WIDTH	THICKNESS mm	HINGE WIDTH mm		PITCH P mm	BASIC WIDTH B mm			H mm	H mm		
981M							0		82 <sup>(2)</sup> /90 <sup>(3)</sup>	F 01	281	
PHD 981M		3		500	85	100	100		90	F 02	282	
PHDG 981M						111	100		90	F 03	283	
					89	100	125		82	F 04	284	
	3 1/4" 83.8 mm		42	680	-	100	100		82	F 05	285	
880M RG		4		750	85	100	100	27	82 <sup>(2)</sup> /90 <sup>(3)</sup>	F 06	286	
				860	-	100	125		90	F 07	287	
				1000	-	100	0		82	F 08	288	
					85	111	100		90	F 09	289	
									90	F 10	290	
981M	4 1/2"	3	42	500	120	129	125	27	90	F 11	291	
PHD 981M				610	120	129	125		90	F 12	292	
					117	129	0		90	F 13	293	
981M	7 1/2"	3	42	610	196	214	125	27	90	F 14	294	
PHD 981M				860	-	214	0		82	F 15	295	
PHDG 981M				1000	-	214	0		82	F 16	296	
PHD 9857M	7 1/2"	3	57	610 <sup>(4)</sup>	195	200	100	32	87 <sup>(2)</sup> /95 <sup>(3)</sup>	H 01	297	
PHDG 9857M		4,8		750	195	200	100		87 <sup>(2)</sup> /95 <sup>(3)</sup>	H 02	298	
882M				860	-	214	0		87	H 03	299	
HFX 882M				1000	-	214	0		87	H 04	300	
882M	10"	4,8	57	860	-	290	0	32		H 05	301	
HFX 882M	12"					340				H 06	302	
	7 1/2"					214				L 01	303	
LBP 882M	10"	4,8	57	860	-	290	0	32	95	L 02	304	
	12"					340				L 03	305	
							0		82 <sup>(2)</sup> /90 <sup>(3)</sup>	M 01	306	
				500	85	100	100		90	M 02	307	
782M	83.8 mm	8,7	42			111	100	27	90	M 03	308	
783M						100	100		90	M 04	309	
				750	85	100	100		90	M 05	310	
						111	100		90	M 06	311	
				1000	85	100	0		90	M 06	311	
							0		82 <sup>(2)</sup> /90 <sup>(3)</sup>	U 01	312	
				500	85	100	100		90	U 02	313	
793M	83.8 mm	12,7	42			111	100	27	90	U 03	314	
				750	85	100	100		90	U 04	315	
				1000	85	100	0		90	U 05	316	
793M	4 1/2"	12,7	42	500	120	129	125	27	90	U 06	317	

<sup>(1)</sup> First track is intended.

<sup>(2)</sup> For curves with one track.

<sup>(3)</sup> For multi tracks curves.

<sup>(4)</sup> 882M and HFX 882M series only.

## VERSION F 01

### SUITABLE FOR CHAINS:

- 981M K 3¼ (See page 37)
- 981M K 83,8 (See page 37)
- PHD 981M K 3¼ (See page 37)
- PHD 981M K 83,8 (See page 37)
- PHDG 981M K 3¼ (See page 45)
- 880M RG K 3¼ (See page 56)
- 880M RG K 83,8 (See page 56)

RADIUS	BASIC WIDTH	TRANSVERSAL PITCH	INFEED/OUTFEED LENGTH
mm	mm	mm	mm
500	100	85	-



Single track

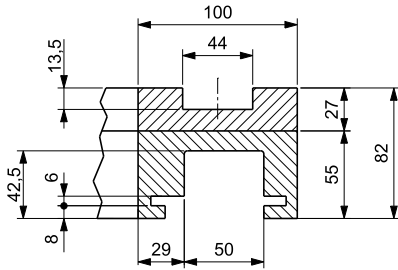

Multi track

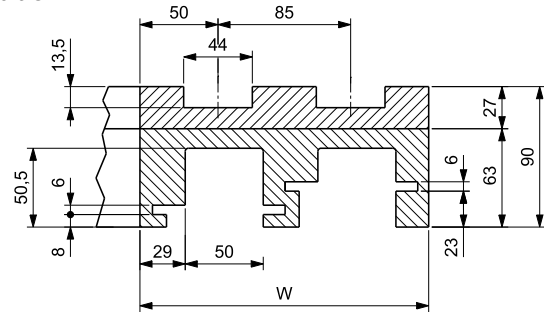

Radius

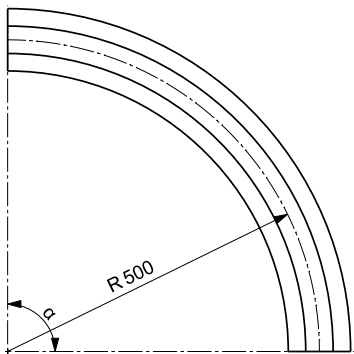

Return guide shoe

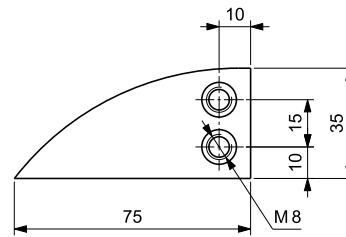

On request, Upper part is available in Self-Lubricating UHMWPE & Oil-filled PA.



CURVES	PART NUMBER IDENTIFICATION		
	SUPREME - A	SUPREME - L	SUPREME - S
UPPER PART MATERIAL	UHMWPE	Self-lubricating UHMWPE	Oil-filled PA
PART NUMBERS	See table below	Replace "MF" with "MFD" Example: 2 tracks, 90° curve angle, P/N: MFD02AAY/110	Replace "MF" with "MFP" Example: 2 tracks, 90° curve angle, P/N: MFP02AAY/110

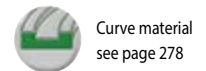
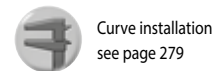

N. OF TRACKS	TOTAL WIDTH W mm	PART NUMBER Curve angle α					
		15°	30°	45°	60°	75°	90°
1	100	MF01AFX/100	MF01AEX/100	MF01ACX/100	MF01ABX/100	MF01ALX/100	MF01AAX/100
2	185	MF02AFY/110	MF02AEY/110	MF02ACY/110	MF02ABY/110	MF02ALY/110	MF02AAY/110
3	270	MF03AFY/110	MF03AEY/110	MF03ACY/110	MF03ABY/110	MF03ALY/110	MF03AAY/110
4	355	MF04AFY/110	MF04AEY/110	MF04ACY/110	MF04ABY/110	MF04ALY/110	MF04AAY/110
5	440	MF05AFY/110	MF05AEY/110	MF05ACY/110	MF05ABY/110	MF05ALY/110	MF05AAY/110
6	525	MF06AFY/110	MF06AEY/110	MF06ACY/110	MF06ABY/110	MF06ALY/110	MF06AAY/110

NOTE: For custom requests with dimensions different from the standard, please refer to page 318.

## VERSION F 02

### SUITABLE FOR CHAINS:

- 981M K 3¼ (See page 37)
- 981M K 83,8 (See page 37)
- PHD 981M K 3¼ (See page 37)
- PHD 981M K 83,8 (See page 37)
- PHDG 981M K 3¼ (See page 45)
- 880M RG K 3¼ (See page 56)
- 880M RG K 83,8 (See page 56)

RADIUS	BASIC WIDTH	TRANSVERSAL PITCH	INFEED/OUTFEED LENGTH
mm	mm	mm	mm
500	100	85	100



Single track

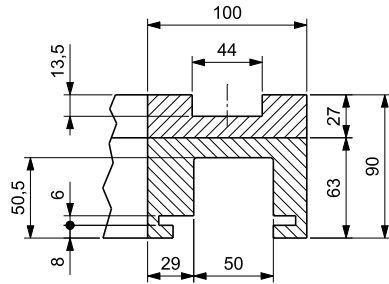

Multi track

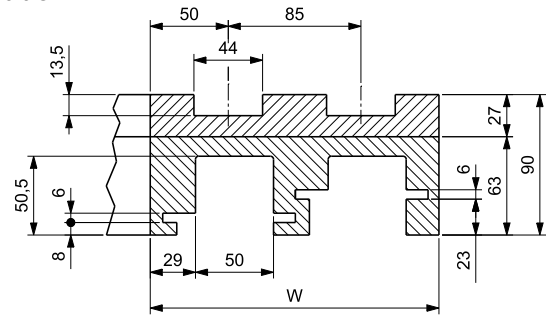

Radius

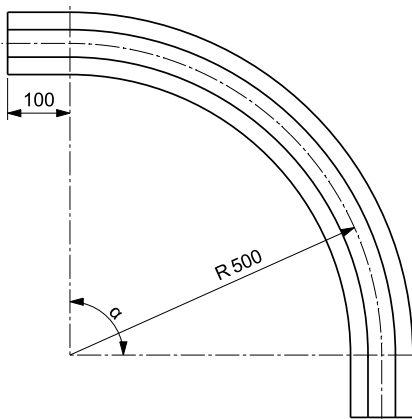

Return guide shoe

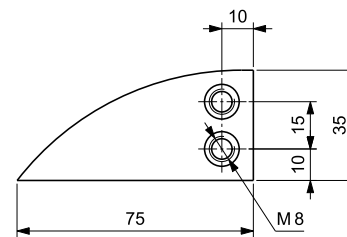

On request, Upper part is available in Self-Lubricating UHMWPE & Oil-filled PA.



CURVES	PART NUMBER IDENTIFICATION		
	SUPREME - A	SUPREME - L	SUPREME - S
UPPER PART MATERIAL	UHMWPE	Self-lubricating UHMWPE	Oil-filled PA
PART NUMBERS	See table below	Replace "MF" with "MFD" Example: 2 tracks, 90° curve angle, P/N: MFD02AAY/111	Replace "MF" with "MFP" Example: 2 tracks, 90° curve angle, P/N: MFP02AAY/111



Curve installation see page 279



Curve material see page 278

N. OF TRACKS	TOTAL WIDTH W mm	PART NUMBER					
		Curve angle α					
		15°	30°	45°	60°	75°	90°
1	100	MF01AFY/101	MF01AEY/101	MF01ACY/101	MF01ABY/101	MF01ALY/101	MF01AAY/101
2	185	MF02AFY/111	MF02AEY/111	MF02ACY/111	MF02ABY/111	MF02ALY/111	MF02AAY/111
3	270	MF03AFY/111	MF03AEY/111	MF03ACY/111	MF03ABY/111	MF03ALY/111	MF03AAY/111
4	355	MF04AFY/111	MF04AEY/111	MF04ACY/111	MF04ABY/111	MF04ALY/111	MF04AAY/111
5	440	MF05AFY/111	MF05AEY/111	MF05ACY/111	MF05ABY/111	MF05ALY/111	MF05AAY/111
6	525	MF06AFY/111	MF06AEY/111	MF06ACY/111	MF06ABY/111	MF06ALY/111	MF06AAY/111

NOTE: For custom requests with dimensions different from the standard, please refer to page 318.

## VERSION F 03

### SUITABLE FOR CHAINS:

- 981M K 3¼ (See page 37)
- 981M K 83,8 (See page 37)
- PHD 981M K 3¼ (See page 37)
- PHD 981M K 83,8 (See page 37)
- PHDG 981M K 3¼ (See page 45)
- 880M RG K 3¼ (See page 56)
- 880M RG K 83,8 (See page 56)

RADIUS	BASIC WIDTH	TRANSVERSAL PITCH	INFEED/OUTFEED LENGTH
mm	mm	mm	mm
500	111	85	100



Single track

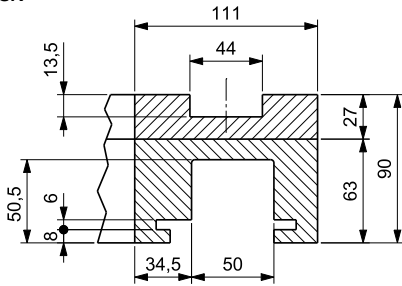

Multi track

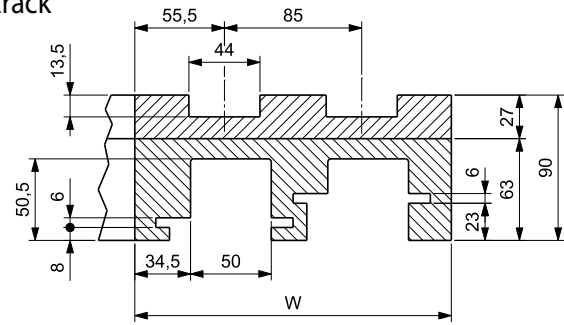

Radius

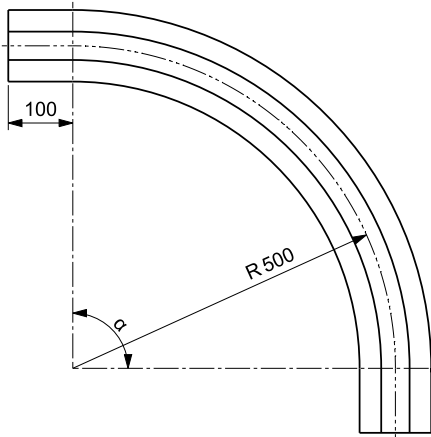

Return guide shoe

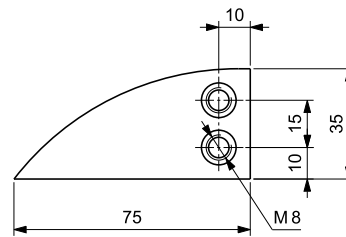

On request, Upper part is available in Self-Lubricating UHMWPE & Oil-filled PA.



PART NUMBER IDENTIFICATION			
CURVES			
UPPER PART MATERIAL	UHMWPE	Self-lubricating UHMWPE	Oil-filled PA
PART NUMBERS	See table below	Replace "MF" with "MFD" Example: 2 tracks, 90° curve angle, P/N: MFD02AAY/311	Replace "MF" with "MFP" Example: 2 tracks, 90° curve angle, P/N: MFP02AAY/311

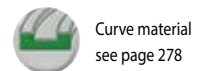
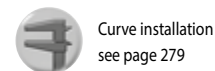

N. OF TRACKS	TOTAL WIDTH W mm	PART NUMBER					
		Curve angle α					
		15°	30°	45°	60°	75°	90°
1	111	MF01AFY/301	MF01AEY/301	MF01ACY/301	MF01ABY/301	MF01ALY/301	MF01AAY/301
2	196	MF02AFY/311	MF02AEY/311	MF02ACY/311	MF02ABY/311	MF02ALY/311	MF02AAY/311
3	281	MF03AFY/311	MF03AEY/311	MF03ACY/311	MF03ABY/311	MF03ALY/311	MF03AAY/311
4	366	MF04AFY/311	MF04AEY/311	MF04ACY/311	MF04ABY/311	MF04ALY/311	MF04AAY/311
5	451	MF05AFY/311	MF05AEY/311	MF05ACY/311	MF05ABY/311	MF05ALY/311	MF05AAY/311
6	536	MF06AFY/311	MF06AEY/311	MF06ACY/311	MF06ABY/311	MF06ALY/311	MF06AAY/311

NOTE: For custom requests with dimensions different from the standard, please refer to page 318.



## VERSION F 04

### SUITABLE FOR CHAINS:

- 981M K 3¼ (See page 37)
- 981M K 83,8 (See page 37)
- PHD 981M K 3¼ (See page 37)
- PHD 981M K 83,8 (See page 37)
- PHDG 981M K 3¼ (See page 45)
- 880M RG K 3¼ (See page 56)
- 880M RG K 83,8 (See page 56)

RADIUS mm	BASIC WIDTH mm	TRANSVERSAL PITCH mm	INFEED/ OUTFEED LENGTH mm
500	100	89	125



### Single track

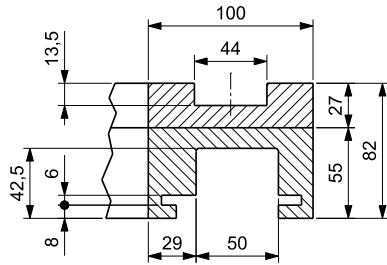

### Multi track

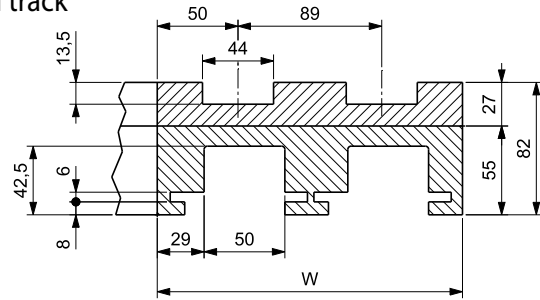

### Radius

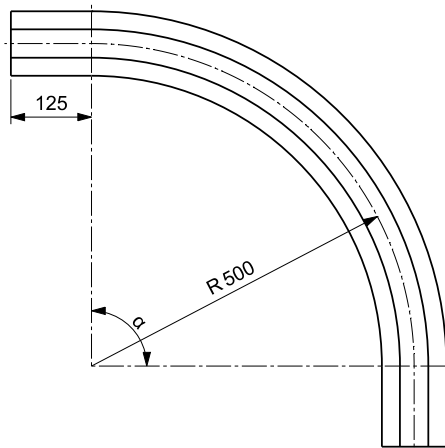

### Return guide shoe

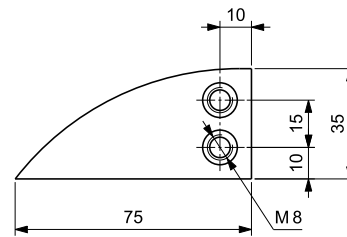

On request, Upper part is available in Self-Lubricating UHMWPE & Oil-filled PA.



PART NUMBER IDENTIFICATION			
CURVES	SUPREME -A	SUPREME -L	SUPREME -S
UPPER PART MATERIAL	UHMWPE	Self-lubricating UHMWPE	Oil-filled PA
PART NUMBERS	See table below	Replace "MF" with "MFD" Example: 2 tracks, 90° curve angle, P/N: MFD02AAX/122	Replace "MF" with "MFP" Example: 2 tracks, 90° curve angle, P/N: MFP02AAX/122



Curve installation see page 279



Curve material see page 278

N. OF TRACKS	TOTAL WIDTH W mm	PART NUMBER					
		Curve angle α					
		15°	30°	45°	60°	75°	90°
1	100	MF01AFX/102	MF01AEX/102	MF01ACX/102	MF01ABX/102	MF01ALX/102	MF01AAX/102
2	189	MF02AFX/122	MF02AEX/122	MF02ACX/122	MF02ABX/122	MF02ALX/122	MF02AAX/122
3	278	MF03AFX/122	MF03AEX/122	MF03ACX/122	MF03ABX/122	MF03ALX/122	MF03AAX/122
4	367	MF04AFX/122	MF04AEX/122	MF04ACX/122	MF04ABX/122	MF04ALX/122	MF04AAX/122
5	456	MF05AFX/122	MF05AEX/122	MF05ACX/122	MF05ABX/122	MF05ALX/122	MF05AAX/122
6	545	MF06AFX/122	MF06AEX/122	MF06ACX/122	MF06ABX/122	MF06ALX/122	MF06AAX/122

NOTE: For custom requests with dimensions different from the standard, please refer to page 318.

## VERSION F 05

### SUITABLE FOR CHAINS:

- 981M K 3¼ (See page 37)
- 981M K 83,8 (See page 37)
- PHD 981M K 3¼ (See page 37)
- PHD 981M K 83,8 (See page 37)
- PHDG 981M K 3¼ (See page 45)
- 880M RG K 3¼ (See page 56)
- 880M RG K 83,8 (See page 56)

RADIUS mm	BASIC WIDTH mm	TRANSVERSAL PITCH mm	INFEEED/ OUTFEED LENGTH mm
680	100	Single track	100



### Single track

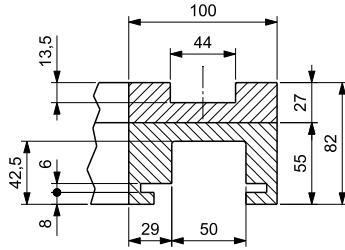

### Radius

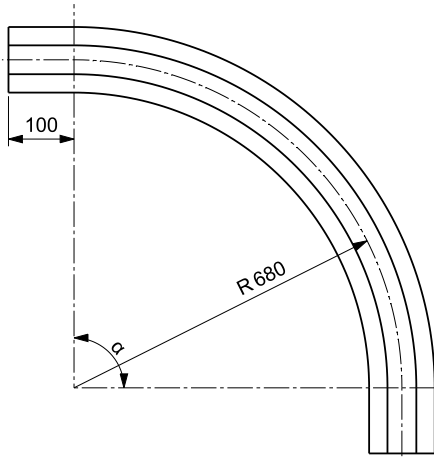

### Return guide shoe

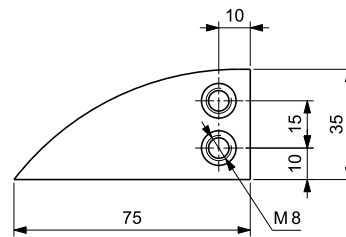

On request, Upper part is available in Self-Lubricating UHMWPE & Oil-filled PA.



CURVES	PART NUMBER IDENTIFICATION		
	SUPREME -A	SUPREME -L	SUPREME -S
UPPER PART MATERIAL	UHMWPE	Self-lubricating UHMWPE	Oil-filled PA
PART NUMBERS	See table below	Replace "MF" with "MFD" Example: 1 track, 90° curve angle, P/N: MFD01DAX/101	Replace "MF" with "MFP" Example: 1 track, 90° curve angle, P/N: MFP01DAX/101



Curve installation see page 279



Curve material see page 278

N. OF TRACKS	TOTAL WIDTH W mm	PART NUMBER					
		Curve angle α					
		15°	30°	45°	60°	75°	90°
1	100	MF01DFX/101	MF01DEX/101	MF01DCX/101	MF01DBX/101	MF01DLX/101	MF01DAX/101

NOTE: For custom requests with dimensions different from the standard, please refer to page 318.

## VERSION F 06

### SUITABLE FOR CHAINS:

- 981M K 3¼ (See page 37)
- 981M K 83,8 (See page 37)
- PHD 981M K 3¼ (See page 37)
- PHD 981M K 83,8 (See page 37)
- PHDG 981M K 3¼ (See page 45)
- 880M RG K 3¼ (See page 56)
- 880M RG K 83,8 (See page 56)

RADIUS mm	BASIC WIDTH mm	TRANSVERSAL PITCH mm	INFEED/ OUTFEED LENGTH mm
750	100	85	100



Single track

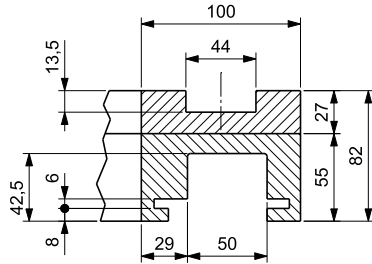

Multi track

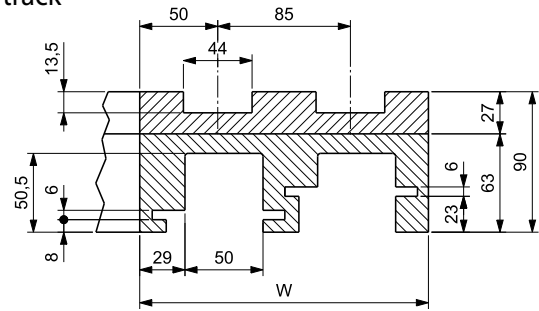

Radius

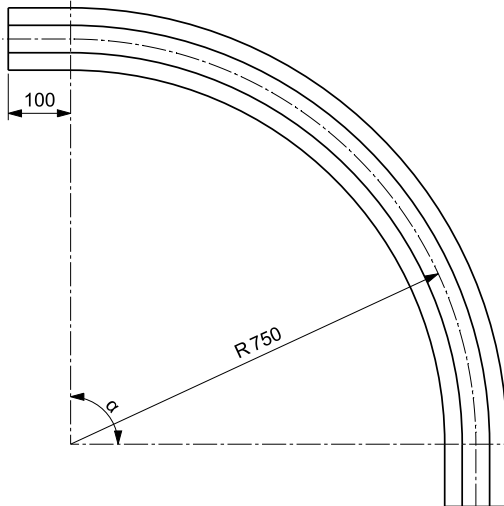

Return guide shoe

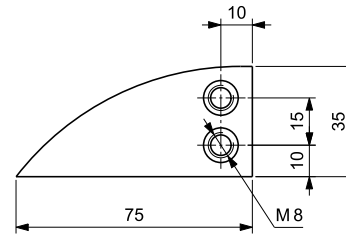

On request, Upper part is available in Self-Lubricating UHMWPE & Oil-filled PA.



CURVES	PART NUMBER IDENTIFICATION		
	SUPREME -A	SUPREME -L	SUPREME -S
UPPER PART MATERIAL	UHMWPE	Self-lubricating UHMWPE	Oil-filled PA
PART NUMBERS	See table below	Replace "MF" with "MFD" Example: 2 tracks, 90° curve angle, P/N: MFD02EAY/111	Replace "MF" with "MFP" Example: 2 tracks, 90° curve angle, P/N: MFP02EAY/111



Curve installation see page 279



Curve material see page 278

N. OF TRACKS	TOTAL WIDTH W mm	PART NUMBER					
		Curve angle α					
		15°	30°	45°	60°	75°	90°
1	100	MF01EFX/101	MF01EEX/101	MF01ECX/101	MF01EBX/101	MF01ELX/101	MF01EAX/101
2	185	MF02EFY/111	MF02EEX/111	MF02ECY/111	MF02EBY/111	MF02ELY/111	MF02EAY/111
3	270	MF03EFY/111	MF03EEX/111	MF03ECY/111	MF03EBY/111	MF03ELY/111	MF03EAY/111
4	335	MF04EFY/111	MF04EEX/111	MF04ECY/111	MF04EBY/111	MF04ELY/111	MF04EAY/111
5	400	MF05EFY/111	MF05EEX/111	MF05ECY/111	MF05EBY/111	MF05ELY/111	MF05EAY/111
6	525	MF06EFY/111	MF06EEX/111	MF06ECY/111	MF06EBY/111	MF06ELY/111	MF06EAY/111

NOTE: For custom requests with dimensions different from the standard, please refer to page 318.

## VERSION F 07

### SUITABLE FOR CHAINS:

- 981M K 3¼ (See page 37)
- 981M K 83,8 (See page 37)
- PHD 981M K 3¼ (See page 37)
- PHD 981M K 83,8 (See page 37)
- PHDG 981M K 3¼ (See page 45)
- 880M RG K 3¼ (See page 56)
- 880M RG K 83,8 (See page 56)

RADIUS mm	BASIC WIDTH mm	TRANSVERSAL PITCH mm	INFEED/ OUTFEED LENGTH mm
750	111	85	100



Single track

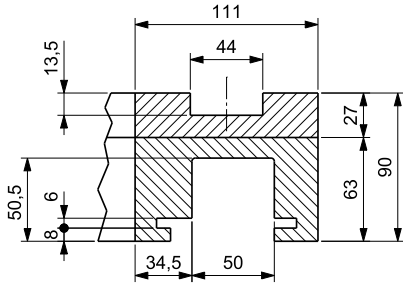

Multi track

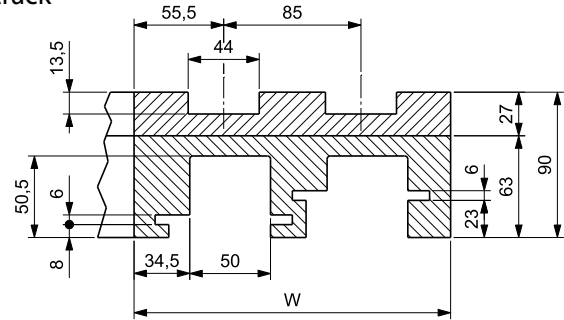

Radius

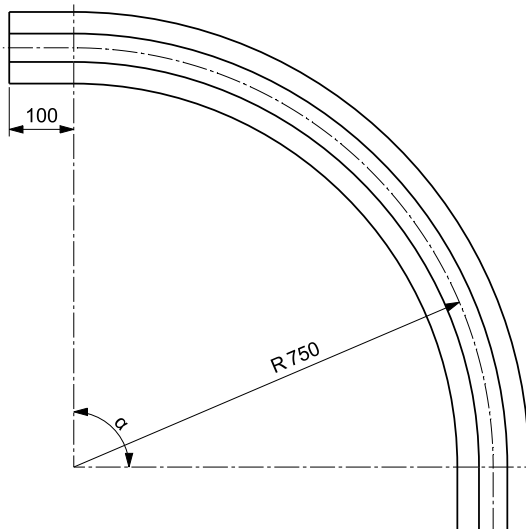

Return guide shoe

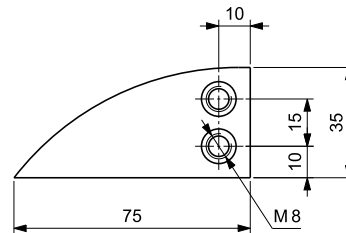

On request, Upper part is available in Self-Lubricating UHMWPE & Oil-filled PA.



CURVES	PART NUMBER IDENTIFICATION		
	SUPREME -A	SUPREME -L	SUPREME -S
UPPER PART MATERIAL	UHMWPE	Self-lubricating UHMWPE	Oil-filled PA
PART NUMBERS	See table below	Replace "MF" with "MFD" Example: 2 tracks, 90° curve angle, P/N: MFD02EAY/311	Replace "MF" with "MFP" Example: 2 tracks, 90° curve angle, P/N: MFP02EAY/311

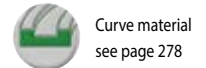
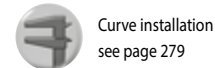

N. OF TRACKS	TOTAL WIDTH W mm	PART NUMBER					
		Curve angle $\alpha$					
		15°	30°	45°	60°	75°	90°
1	111	MF01EFY/301	MF01EEY/301	MF01ECY/301	MF01EBY/301	MF01ELY/301	MF01EAY/301
2	196	MF02EFY/311	MF02EEY/311	MF02ECY/311	MF02EBY/311	MF02ELY/311	MF02EAY/311
3	281	MF03EFY/311	MF03EEY/311	MF03ECY/311	MF03EBY/311	MF03ELY/311	MF03EAY/311
4	366	MF04EFY/311	MF04EEY/311	MF04ECY/311	MF04EBY/311	MF04ELY/311	MF04EAY/311
5	451	MF05EFY/311	MF05EEY/311	MF05ECY/311	MF05EBY/311	MF05ELY/311	MF05EAY/311
6	536	MF06EFY/311	MF06EEY/311	MF06ECY/311	MF06EBY/311	MF06ELY/311	MF06EAY/311

NOTE: For custom requests with dimensions different from the standard, please refer to page 318.

## VERSION F 08

### SUITABLE FOR CHAINS:

- 981M K 3¼ (See page 37)
- 981M K 83,8 (See page 37)
- PHD 981M K 3¼ (See page 37)
- PHD 981M K 83,8 (See page 37)
- PHDG 981M K 3¼ (See page 45)
- 880M RG K 3¼ (See page 56)
- 880M RG K 83,8 (See page 56)

RADIUS mm	BASIC WIDTH mm	TRANSVERSAL PITCH mm	INFEED/ OUTFEED LENGTH mm
860	100	Single track	125



### Single track

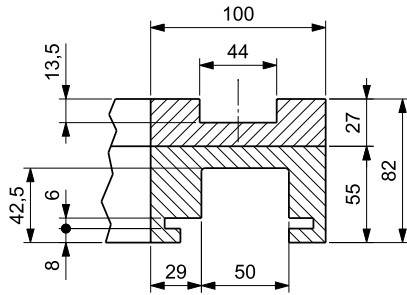

### Radius

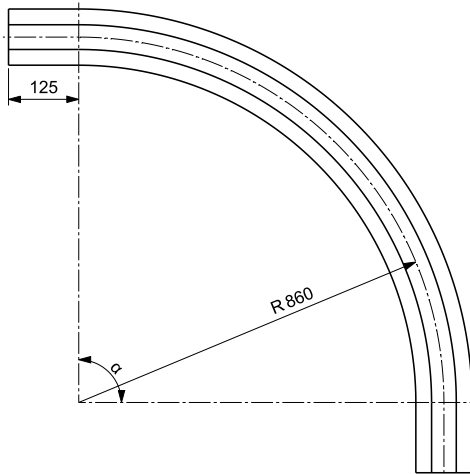

### Return guide shoe

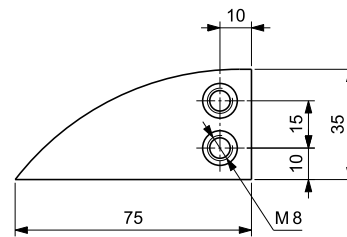

On request, Upper part is available in Self-Lubricating UHMWPE & Oil-filled PA.



CURVES	PART NUMBER IDENTIFICATION		
	SUPREME -A	SUPREME -L	SUPREME -S
UPPER PART MATERIAL	UHMWPE	Self-lubricating UHMWPE	Oil-filled PA
PART NUMBERS	See table below	Replace "MF" with "MFD" Example: 1 track, 90° curve angle, P/N: MFD01FAX/102	Replace "MF" with "MFP" Example: 1 track, 90° curve angle, P/N: MFP01FAX/102



Curve installation see page 279



Curve material see page 278

N. OF TRACKS	TOTAL WIDTH W mm	PART NUMBER					
		Curve angle $\alpha$					
		15°	30°	45°	60°	75°	90°
1	100	MF01FFX/102	MF01FEX/102	MF01FCX/102	MF01FBX/102	MF01FLX/102	MF01FAX/102

NOTE: For custom requests with dimensions different from the standard, please refer to page 318.

## VERSION F 09

### SUITABLE FOR CHAINS:

- 981M K 3¼ (See page 37)
- 981M K 83,8 (See page 37)
- PHD 981M K 3¼ (See page 37)
- PHD 981M K 83,8 (See page 37)
- PHDG 981M K 3¼ (See page 45)
- 880M RG K 3¼ (See page 56)
- 880M RG K 83,8 (See page 56)

RADIUS mm	BASIC WIDTH mm	TRANSVERSAL PITCH mm	INFEEED/ OUTFEED LENGTH mm
1000	100	Single track	-



Single track

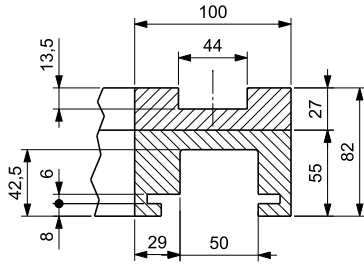

Radius

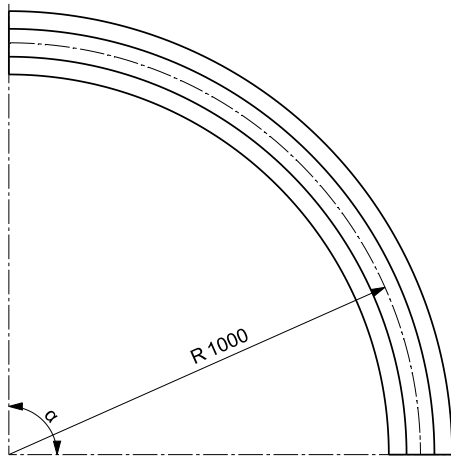

Return guide shoe

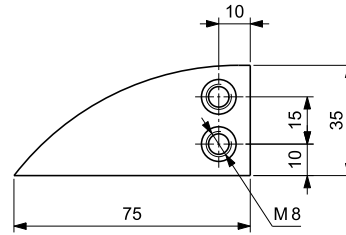

On request, Upper part is available in Self-Lubricating UHMWPE & Oil-filled PA.



CURVES	PART NUMBER IDENTIFICATION		
	SUPREME -A	SUPREME -L	SUPREME -S
UPPER PART MATERIAL	UHMWPE	Self-lubricating UHMWPE	Oil-filled PA
PART NUMBERS	See table below	Replace "MF" with "MFD" Example: 1 track, 90° curve angle, P/N: MFD01GAX/102	Replace "MF" with "MFP" Example: 1 track, 90° curve angle, P/N: MFP01GAX/102



Curve installation see page 279



Curve material see page 278

N. OF TRACKS	TOTAL WIDTH W mm	PART NUMBER					
		Curve angle α					
		15°	30°	45°	60°	75°	90°
1	100	MF01GFX/100	MF01GEX/100	MF01GCX/100	MF01GBX/100	MF01GLX/100	MF01GAX/100

NOTE: For custom requests with dimensions different from the standard, please refer to page 318.



## VERSION F 10

### SUITABLE FOR CHAINS:

- 981M K 3¼ (See page 37)
- 981M K 83,8 (See page 37)
- PHD 981M K 3¼ (See page 37)
- PHD 981M K 83,8 (See page 37)
- PHDG 981M K 3¼ (See page 45)
- 880M RG K 3¼ (See page 56)
- 880M RG K 83,8 (See page 56)

RADIUS	BASIC WIDTH	TRANSVERSAL PITCH	INFEEED/OUTFEED LENGTH
mm	mm	mm	mm
1000	111	85	100



Single track

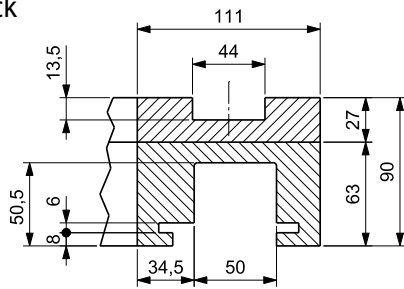

Multi track

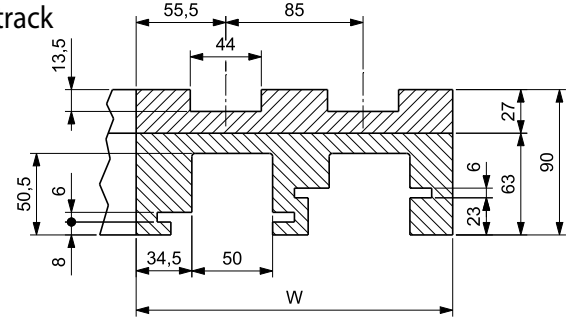

Radius

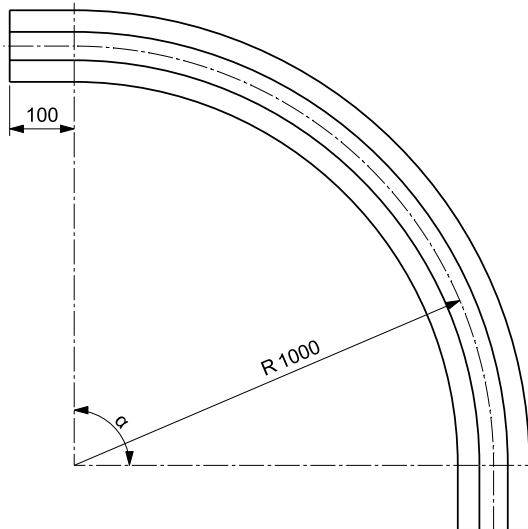

Return guide shoe

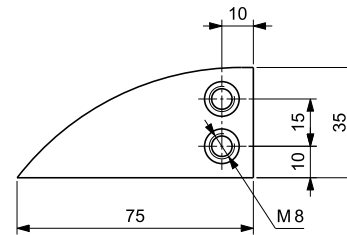

On request, Upper part is available in Self-Lubricating UHMWPE & Oil-filled PA.



### PART NUMBER IDENTIFICATION

CURVES			
UPPER PART MATERIAL	UHMWPE	Self-lubricating UHMWPE	Oil-filled PA
PART NUMBERS	See table below	Replace "MF" with "MFD" Example: 2 tracks, 90° curve angle, P/N: MFD02GAY/311	Replace "MF" with "MFP" Example: 2 tracks, 90° curve angle, P/N: MFP02GAY/311



Curve installation see page 279



Curve material see page 278

N. OF TRACKS	TOTAL WIDTH W mm	PART NUMBER					
		Curve angle $\alpha$					
		15°	30°	45°	60°	75°	90°
1	111	MF01GFY/301	MF01GEY/301	MF01GKY/301	MF01GBY/301	MF01GLY/301	MF01GAY/301
2	196	MF02GFY/311	MF02GEY/311	MF02GKY/311	MF02GBY/311	MF02GLY/311	MF02GAY/311
3	281	MF03GFY/311	MF03GEY/311	MF03GKY/311	MF03GBY/311	MF03GLY/311	MF03GAY/311
4	366	MF04GFY/311	MF04GEY/311	MF04GKY/311	MF04GBY/311	MF04GLY/311	MF04GAY/311
5	451	MF05GFY/311	MF05GEY/311	MF05GKY/311	MF05GBY/311	MF05GLY/311	MF05GAY/311
6	536	MF06GFY/311	MF06GEY/311	MF06GKY/311	MF06GBY/311	MF06GLY/311	MF06GAY/311

NOTE: For custom requests with dimensions different from the standard, please refer to page 318.

## VERSION F 11

### SUITABLE FOR CHAINS:

- 981M K 4½ (See page 37)
- PHD 981M K 4½ (See page 37)
- 880M RG K 4½ (See page 56)

RADIUS mm	BASIC WIDTH mm	TRANSVERSAL PITCH mm	INFEED/ OUTFEED LENGTH mm
500	129	120	125



Single track

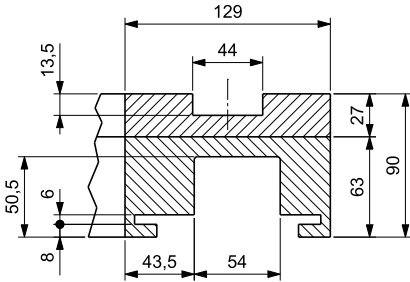

Multi track

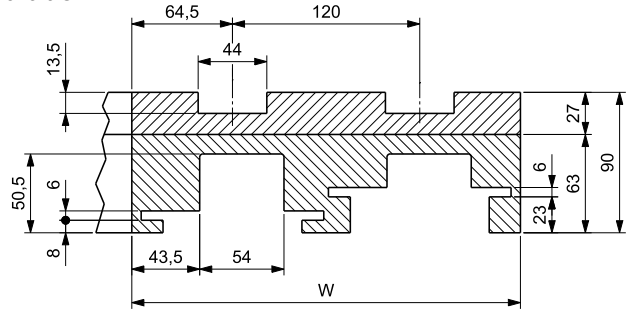

Radius

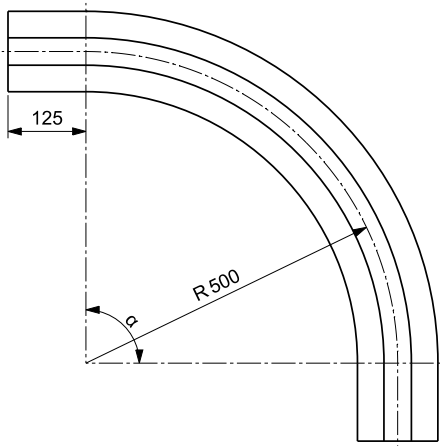

Return guide shoe

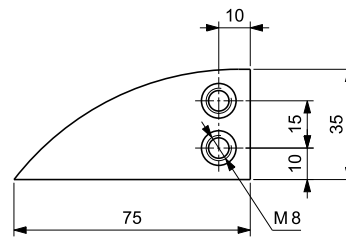

On request, Upper part is available in Self-Lubricating UHMWPE & Oil-filled PA.



CURVES	PART NUMBER IDENTIFICATION		
	SUPREME -A	SUPREME -L	SUPREME -S
UPPER PART MATERIAL	UHMWPE	Self-lubricating UHMWPE	Oil-filled PA
PART NUMBERS	See table below	Replace "MF" with "MFD" Example: 2 tracks, 90° curve angle, P/N: MFD02AA/442	Replace "MF" with "MFP" Example: 2 tracks, 90° curve angle, P/N: MFP02AA/442

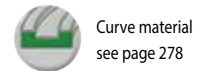
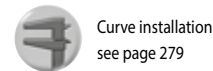

N. OF TRACKS	TOTAL WIDTH W mm	PART NUMBER					
		Curve angle $\alpha$					
		15°	30°	45°	60°	75°	90°
1	129	MF01AFY/402	MF01AEY/402	MF01ACY/402	MF01ABY/402	MF01ALY/402	MF01AAY/402
2	249	MF02AFY/442	MF02AEY/442	MF02ACY/442	MF02ABY/442	MF02ALY/442	MF02AAY/442
3	369	MF03AFY/442	MF03AEY/442	MF03ACY/442	MF03ABY/442	MF03ALY/442	MF03AAY/442
4	489	MF04AFY/442	MF04AEY/442	MF04ACY/442	MF04ABY/442	MF04ALY/442	MF04AAY/442
5	609	MF05AFY/442	MF05AEY/442	MF05ACY/442	MF05ABY/442	MF05ALY/442	MF05AAY/442
6	729	MF06AFY/442	MF06AEY/442	MF06ACY/442	MF06ABY/442	MF06ALY/442	MF06AAY/442

NOTE: For custom requests with dimensions different from the standard, please refer to page 318.

## VERSION F 12

### SUITABLE FOR CHAINS:

- 981M K 4½ (See page 37)
- PHD 981M K 4½ (See page 37)
- 880M RG K 4½ (See page 56)

RADIUS	BASIC WIDTH	TRANSVERSAL PITCH	INFEED/OUTFEED LENGTH
mm	mm	mm	mm
610	129	120	125



Single track

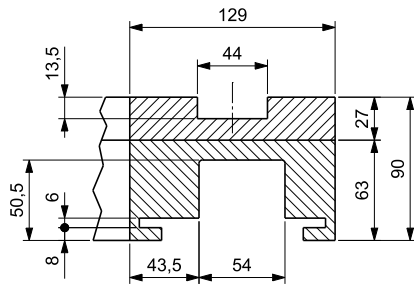

Multi track

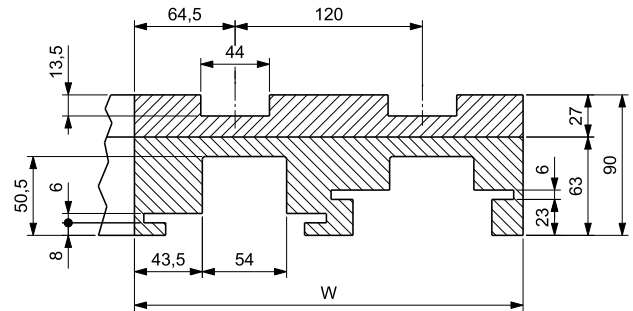

Radius

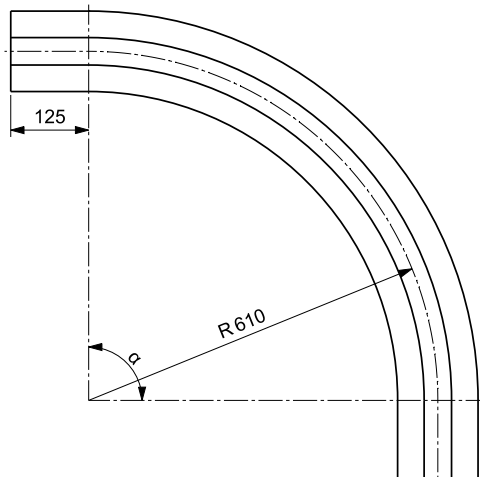

Return guide shoe

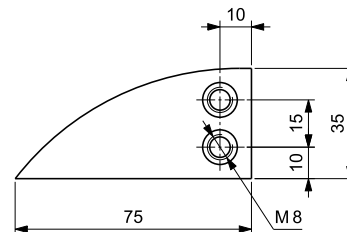

On request, Upper part is available in Self-Lubricating UHMWPE & Oil-filled PA.



CURVES	PART NUMBER IDENTIFICATION		
UPPER PART MATERIAL	UHMWPE	Self-lubricating UHMWPE	Oil-filled PA
PART NUMBERS	See table below	Replace "MF" with "MFD" Example: 2 tracks, 90° curve angle, P/N: MFD02CAY/442	Replace "MF" with "MFP" Example: 2 tracks, 90° curve angle, P/N: MFP02CAY/442



Curve installation see page 279



Curve material see page 278

N. OF TRACKS	TOTAL WIDTH W mm	PART NUMBER					
		Curve angle $\alpha$					
		15°	30°	45°	60°	75°	90°
1	129	MF01CFY/402	MF01CEY/402	MF01CCY/402	MF01CBY/402	MF01CLY/402	MF01CAY/402
2	249	MF02CFY/442	MF02CEY/442	MF02CCY/442	MF02CBY/442	MF02CLY/442	MF02CAY/442
3	369	MF03CFY/442	MF03CEY/442	MF03CCY/442	MF03CBY/442	MF03CLY/442	MF03CAY/442
4	489	MF04CFY/442	MF04CEY/442	MF04CCY/442	MF04CBY/442	MF04CLY/442	MF04CAY/442
5	609	MF05CFY/442	MF05CEY/442	MF05CCY/442	MF05CBY/442	MF05CLY/442	MF05CAY/442
6	729	MF06CFY/442	MF06CEY/442	MF06CCY/442	MF06CBY/442	MF06CLY/442	MF06CAY/442

NOTE: For custom requests with dimensions different from the standard, please refer to page 318.

## VERSION F 13

### SUITABLE FOR CHAINS:

- 981M K 4½ (See page 37)
- PHD 981M K 4½ (See page 37)
- 880M RG K 4½ (See page 56)

RADIUS mm	BASIC WIDTH mm	TRANSVERSAL PITCH mm	INFEED/ OUTFEED LENGTH mm
610	129	117	-



Single track

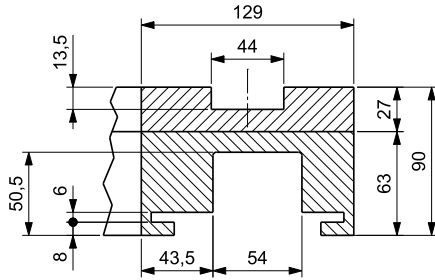

Multi track

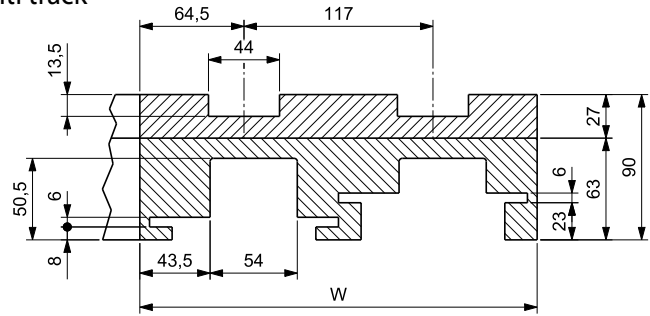

Radius

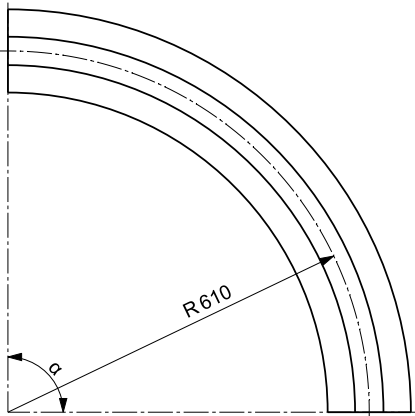

Return guide shoe

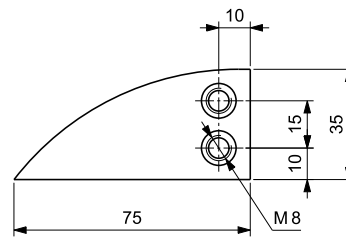

On request, Upper part is available in Self-Lubricating UHMWPE & Oil-filled PA.



CURVES	PART NUMBER IDENTIFICATION		
	SUPREME - A	SUPREME - L	SUPREME - S
UPPER PART MATERIAL	UHMWPE	Self-lubricating UHMWPE	Oil-filled PA
PART NUMBERS	See table below	Replace "MF" with "MFD" Example: 2 tracks, 90° curve angle, P/N: MFD02CAY/450	Replace "MF" with "MFP" Example: 2 tracks, 90° curve angle, P/N: MFP02CAY/450



Curve installation see page 279



Curve material see page 278

N. OF TRACKS	TOTAL WIDTH W mm	PART NUMBER					
		Curve angle $\alpha$					
		15°	30°	45°	60°	75°	90°
1	129	MF01CFY/400	MF01CEY/400	MF01CCY/400	MF01CBY/400	MF01CLY/400	MF01CAY/400
2	246	MF02CFY/450	MF02CEY/450	MF02CCY/450	MF02CBY/450	MF02CLY/450	MF02CAY/450
3	363	MF03CFY/450	MF03CEY/450	MF03CCY/450	MF03CBY/450	MF03CLY/450	MF03CAY/450
4	480	MF04CFY/450	MF04CEY/450	MF04CCY/450	MF04CBY/450	MF04CLY/450	MF04CAY/450
5	597	MF05CFY/450	MF05CEY/450	MF05CCY/450	MF05CBY/450	MF05CLY/450	MF05CAY/450
6	714	MF06CFY/450	MF06CEY/450	MF06CCY/450	MF06CBY/450	MF06CLY/450	MF06CAY/450

NOTE: For custom requests with dimensions different from the standard, please refer to page 318.

## VERSION F 14

### SUITABLE FOR CHAINS:

- 981M K 7½ (See page 37)
- PHD 981M K 7½ (See page 37)
- PHDG 981M K 7½ (See page 45)

RADIUS mm	BASIC WIDTH mm	TRANSVERSAL PITCH mm	INFEED/ OUTFEED LENGTH mm
610	214	196	125

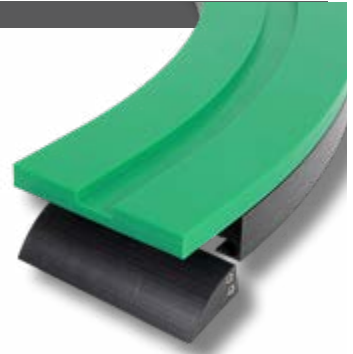

### Single track

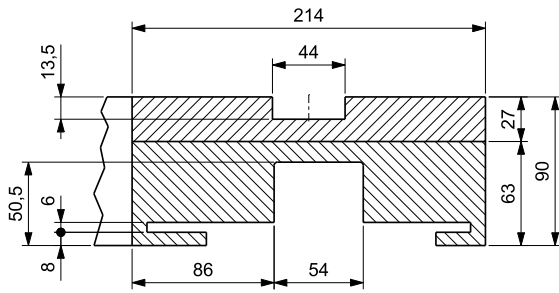

### Multi track

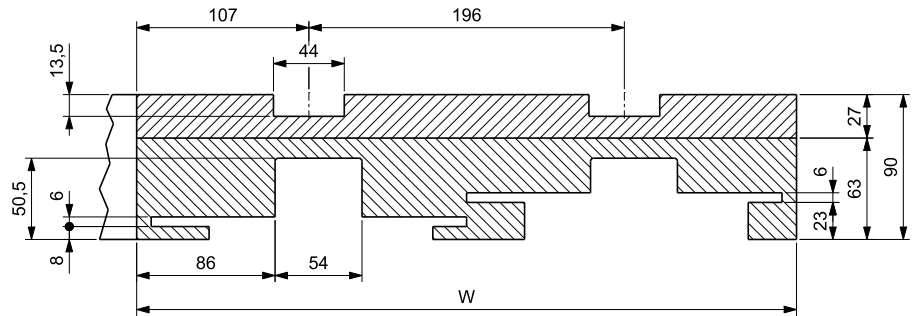

### Radius

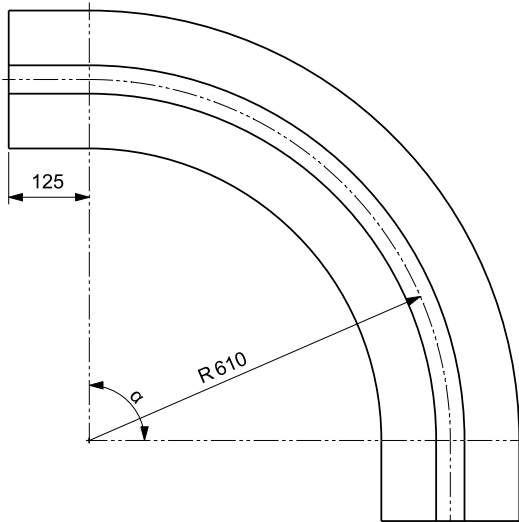

### Return guide shoe

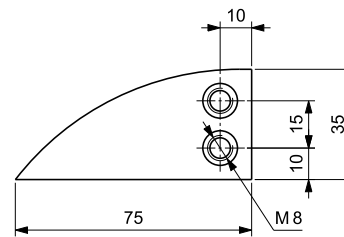

On request, Upper part is available in Self-Lubricating UHMWPE & Oil-filled PA.



CURVES	PART NUMBER IDENTIFICATION		
UPPER PART MATERIAL	UHMWPE	Self-lubricating UHMWPE	Oil-filled PA
PART NUMBERS	See table below	Replace "MF" with "MFD" Example: 2 tracks, 90° curve angle, P/N: MFD02CAY/672	Replace "MF" with "MFP" Example: 2 tracks, 90° curve angle, P/N: MFP02CAY/672



Curve installation  
see page 279



Curve material  
see page 278

N. OF TRACKS	TOTAL WIDTH W mm	PART NUMBER					
		Curve angle α					
		15°	30°	45°	60°	75°	90°
1	214	MF01CFY/602	MF01CEY/602	MF01CCY/602	MF01CBY/602	MF01CLY/602	MF01CAY/602
2	410	MF02CFY/672	MF02CEY/672	MF02CCY/672	MF02CBY/672	MF02CLY/672	MF02CAY/672
3	606	MF03CFY/672	MF03CEY/672	MF03CCY/672	MF03CBY/672	MF03CLY/672	MF03CAY/672
4	802	MF04CFY/672	MF04CEY/672	MF04CCY/672	MF04CBY/672	MF04CLY/672	MF04CAY/672

NOTE: For custom requests with dimensions different from the standard, please refer to page 318.

## VERSION F 15

### SUITABLE FOR CHAINS:

- 981M K 7½ (See page 37)
- PHD 981M K 7½ (See page 37)
- PHDG 981M K 7½ (See page 45)

RADIUS mm	BASIC WIDTH mm	TRANSVERSAL PITCH mm	INFEEED/ OUTFEED LENGTH mm
860	214	Single track	-

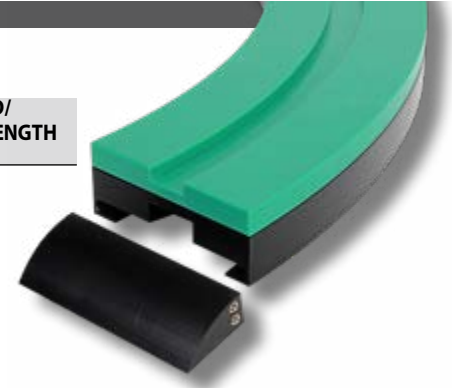

Single track

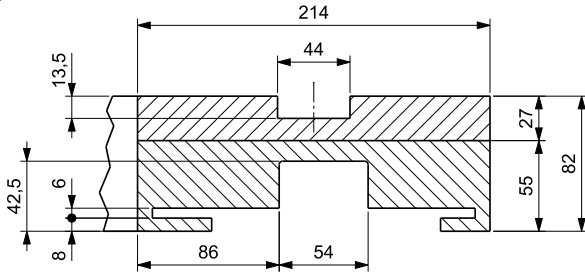

Radius

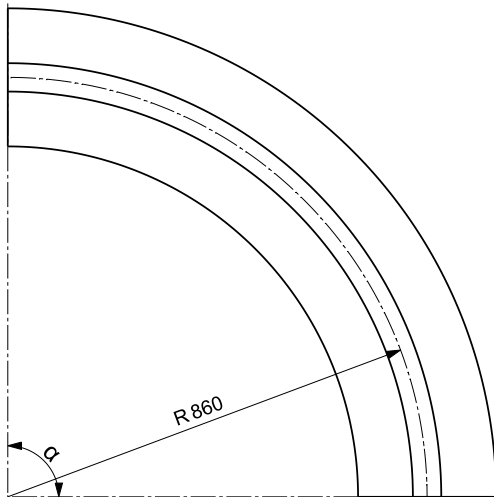

Return guide shoe

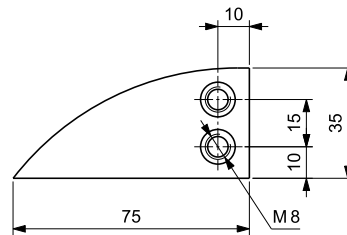

On request, Upper part is available in Self-Lubricating UHMWPE & Oil-filled PA.



CURVES	PART NUMBER IDENTIFICATION		
	SUPREME -A	SUPREME -L	SUPREME -S
UPPER PART MATERIAL	UHMWPE	Self-lubricating UHMWPE	Oil-filled PA
PART NUMBERS	See table below	Replace "MF" with "MFD" Example: 1 track, 90° curve angle, P/N: MFD01FAX/600	Replace "MF" with "MFP" Example: 1 track, 90° curve angle, P/N: MFP01FAX/600



Curve installation see page 279



Curve material see page 278

N. OF TRACKS	TOTAL WIDTH W mm	PART NUMBER					
		Curve angle $\alpha$					
		15°	30°	45°	60°	75°	90°
1	214	MF01FFX/600	MF01FEX/600	MF01FCX/600	MF01FBX/600	MF01FLX/600	MF01FAX/600

NOTE: For custom requests with dimensions different from the standard, please refer to page 318.



## VERSION F 16

### SUITABLE FOR CHAINS:

- 981M K 7½ (See page 37)
- PHD 981M K 7½ (See page 37)
- PHDG 981M K 7½ (See page 45)

RADIUS mm	BASIC WIDTH mm	TRANSVERSAL PITCH mm	INFEED/ OUTFEED LENGTH mm
1000	214	Single track	-

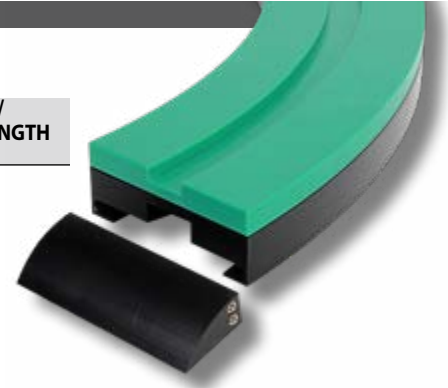

Single track

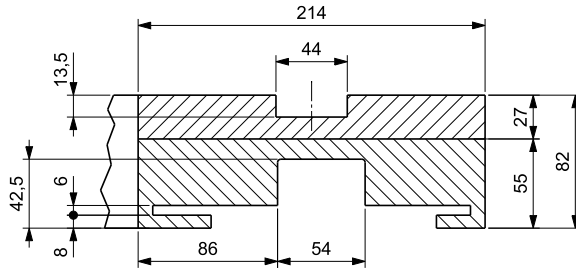

Radius

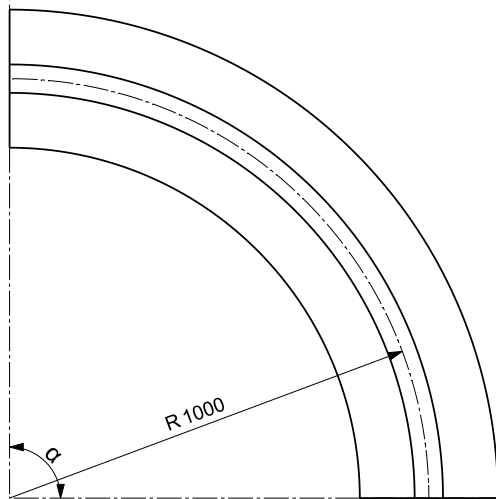

Return guide shoe

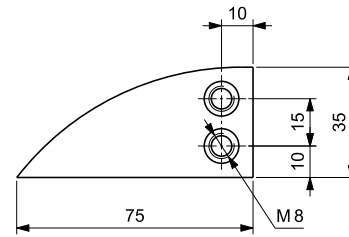

On request, Upper part is available in Self-Lubricating UHMWPE & Oil-filled PA.



CURVES	PART NUMBER IDENTIFICATION		
	SUPREME -A	SUPREME -L	SUPREME -S
UPPER PART MATERIAL	UHMWPE	Self-lubricating UHMWPE	Oil-filled PA
PART NUMBERS	See table below	Replace "MF" with "MFD" Example: 1 track, 90° curve angle, P/N: MFD01GAX/600	Replace "MF" with "MFP" Example: 1 track, 90° curve angle, P/N: MFP01GAX/600



Curve installation see page 279



Curve material see page 278

N. OF TRACKS	TOTAL WIDTH W mm	PART NUMBER					
		15°	30°	45°	60°	75°	90°
1	214	MF01GFX/600	MF01GEX/600	MF01GCX/600	MF01GBX/600	MF01GLX/600	MF01GAX/600

NOTE: For custom requests with dimensions different from the standard, please refer to page 318.

## VERSION H 01

### SUITABLE FOR CHAINS:

- PHD 9857M K 7½ (See page 37)
- PHDG 9857M K 7½ (See page 37)
- 882M K 7½ (See page 61)
- HFX 882M K 7½ (See page 70)

RADIUS	BASIC WIDTH	TRANSVERSAL PITCH	INFEEED/OUTFEED LENGTH
mm	mm	mm	mm
610	200	195	100

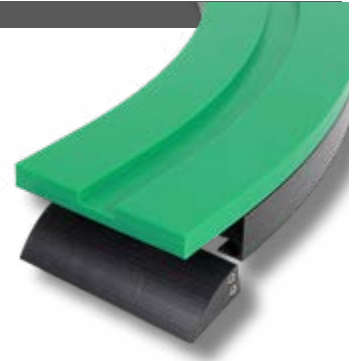

Single track

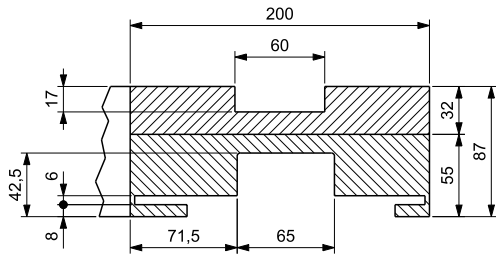

Multi track

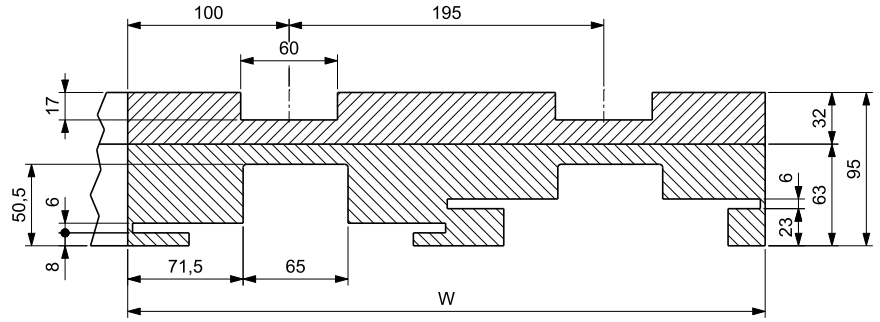

Radius

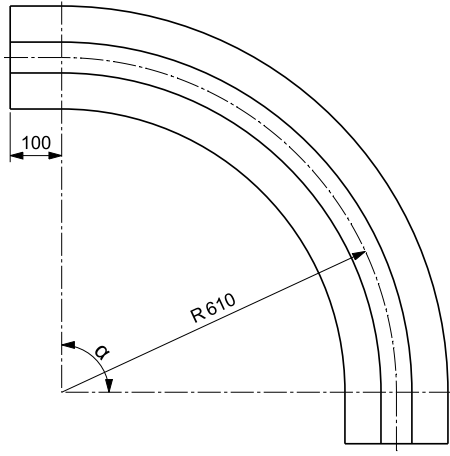

Return guide shoe

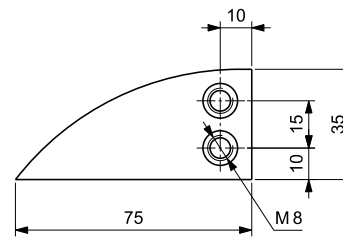

On request, Upper part is available in Self-Lubricating UHMWPE & Oil-filled PA.



CURVES	PART NUMBER IDENTIFICATION		
	SUPREME -A	SUPREME -L	SUPREME -S
UPPER PART MATERIAL	UHMWPE	Self-lubricating UHMWPE	Oil-filled PA
PART NUMBERS	See table below	Replace "MH" with "MHD" Example: 2 tracks, 90° curve angle, P/N: MHD02CAZ/561	Replace "MH" with "MHP" Example: 2 tracks, 90° curve angle, P/N: MHP02CAZ/561

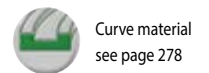
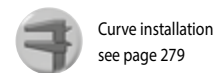

N. OF TRACKS	TOTAL WIDTH W mm	PART NUMBER					
		Curve angle α					
		15°	30°	45°	60°	75°	90°
1	200	MH01CFW/501	MH01CEW/501	MH01CCW/501	MH01CBW/501	MH01CLW/501	MH01CAW/501
2	395	MH02CFZ/561	MH02CEZ/561	MH02CCZ/561	MH02CBZ/561	MH02CLZ/561	MH02CAZ/561
3	590	MH03CFZ/561	MH03CEZ/561	MH03CCZ/561	MH03CBZ/561	MH03CLZ/561	MH03CAZ/561
4	785	MH04CFZ/561	MH04CEZ/561	MH04CCZ/561	MH04CBZ/561	MH04CLZ/561	MH04CAZ/561

NOTE: For custom requests with dimensions different from the standard, please refer to page 318.

## VERSION H 02

### SUITABLE FOR CHAINS:

- PHD 9857M K 7½ (See page 37)
- PHDG 9857M K 7½ (See page 37)
- 882M K 7½ (See page 61)
- HFX 882M K 7½ (See page 70)

RADIUS mm	BASIC WIDTH mm	TRANSVERSAL PITCH mm	INFEED/ OUTFEED LENGTH mm
750	200	195	100

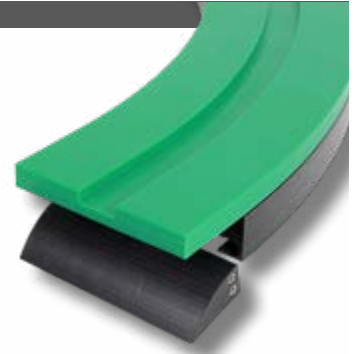

Single track

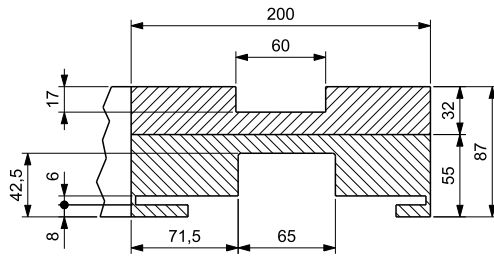

Multi track

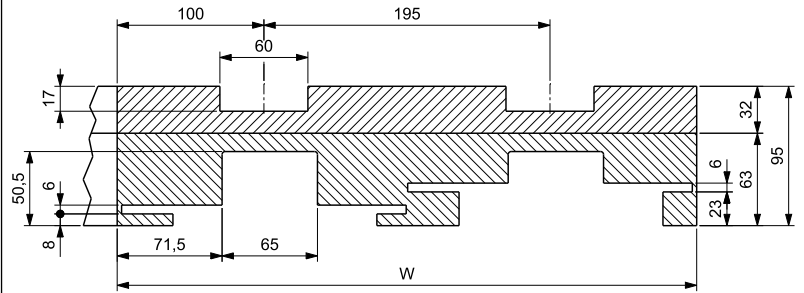

Radius

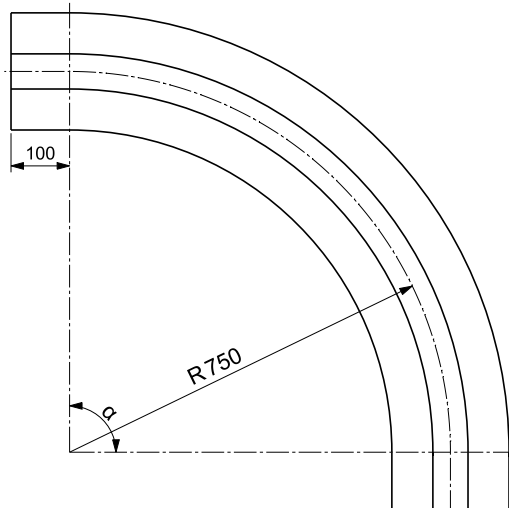

Return guide shoe

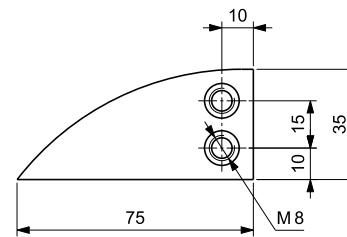

On request, Upper part is available in Self-Lubricating UHMWPE & Oil-filled PA.



CURVES	PART NUMBER IDENTIFICATION		
	SUPREME -A	SUPREME -L	SUPREME -S
UPPER PART MATERIAL	UHMWPE	Self-lubricating UHMWPE	Oil-filled PA
PART NUMBERS	See table below	Replace "MH" with "MHD" Example: 2 tracks, 90° curve angle, P/N: MHD02EAZ/561	Replace "MH" with "MHP" Example: 2 tracks, 90° curve angle, P/N: MHP02EAZ/561



Curve installation see page 279



Curve material see page 278

N. OF TRACKS	TOTAL WIDTH W mm	PART NUMBER					
		Curve angle α					
		15°	30°	45°	60°	75°	90°
1	200	MH01EFW/501	MH01EEW/501	MH01ECW/501	MH01EBW/501	MH01ELW/501	MH01EAW/501
2	395	MH02EFZ/561	MH02EEZ/561	MH02ECZ/561	MH02EBZ/561	MH02ELZ/561	MH02EAZ/561
3	590	MH03EFZ/561	MH03EEZ/561	MH03ECZ/561	MH03EBZ/561	MH03ELZ/561	MH03EAZ/561
4	785	MH04EFZ/561	MH04EEZ/561	MH04ECZ/561	MH04EBZ/561	MH04ELZ/561	MH04EAZ/561

NOTE: For custom requests with dimensions different from the standard, please refer to page 318.

## VERSION H 03

### SUITABLE FOR CHAINS:

- PHD 9857M K 7½ (See page 37)
- PHDG 9857M K 7½ (See page 37)
- 882M K 7½ (See page 61)
- HFX 882M K 7½ (See page 70)

RADIUS mm	BASIC WIDTH mm	TRANSVERSAL PITCH mm	INFEEED/ OUTFEED LENGTH mm
860	214	Single track	-

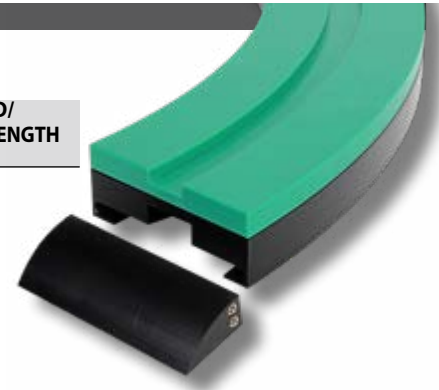

Single track

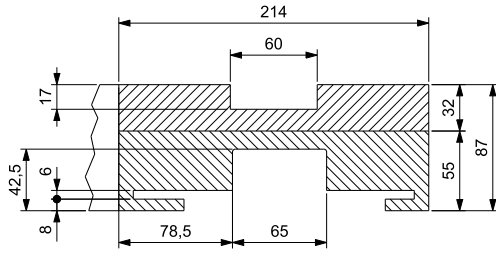

Radius

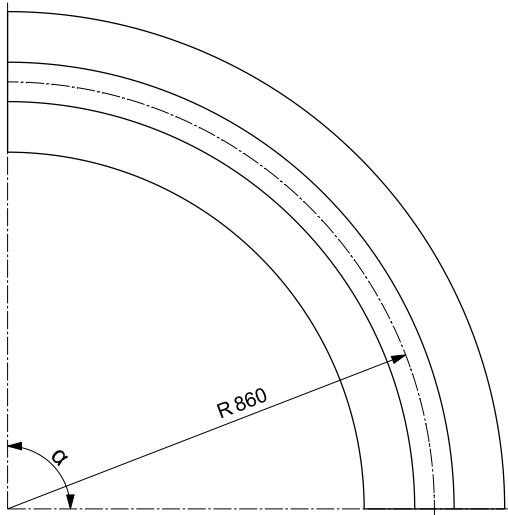

Return guide shoe

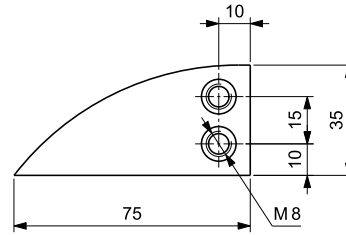

On request, Upper part is available in Self-Lubricating UHMWPE & Oil-filled PA.



CURVES	PART NUMBER IDENTIFICATION		
	SUPREME -A	SUPREME -L	SUPREME -S
UPPER PART MATERIAL	UHMWPE	Self-lubricating UHMWPE	Oil-filled PA
PART NUMBERS	See table below	Replace "MH" with "MHD" Example: 1 track, 90° curve angle, P/N: MHD01FAW/600	Replace "MH" with "MHP" Example: 1 track, 90° curve angle, P/N: MHP01FAW/600



Curve installation see page 279



Curve material see page 278

N. OF TRACKS	TOTAL WIDTH W mm	PART NUMBER					
		Curve angle $\alpha$					
		15°	30°	45°	60°	75°	90°
1	214	MH01FFW/600	MH01FEW/600	MH01FCW/600	MH01FBW/600	MH01FLW/600	MH01FAW/600

NOTE: For custom requests with dimensions different from the standard, please refer to page 318.

## VERSION H 04

### SUITABLE FOR CHAINS:

- PHD 9857M K 7½ (See page 37)
- PHDG 9857M K 7½ (See page 37)
- 882M K 7½ (See page 61)
- HFX 882M K 7½ (See page 70)

RADIUS	BASIC WIDTH	TRANSVERSAL PITCH	INFEED/ OUFEEED LENGTH
mm	mm	mm	mm
1000	214	Single track	-

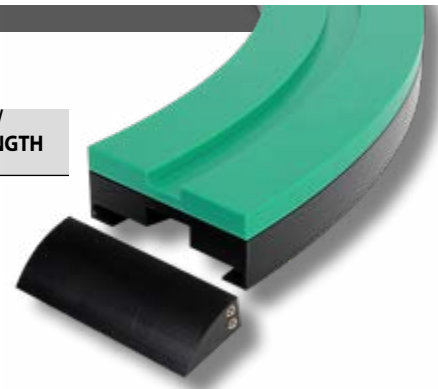

Single track

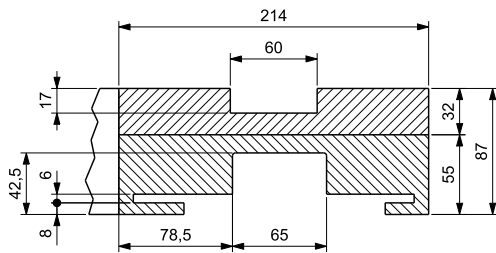

Radius

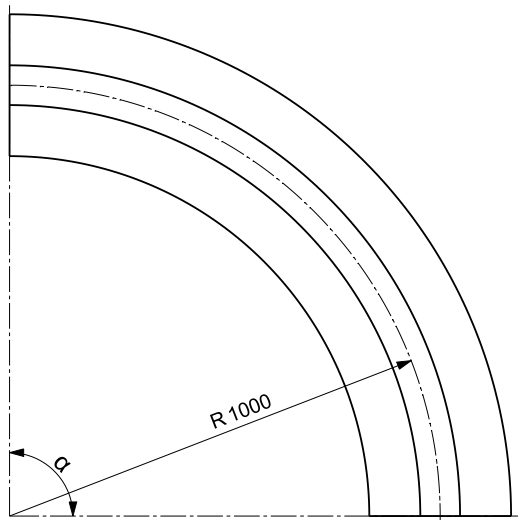

Return guide shoe

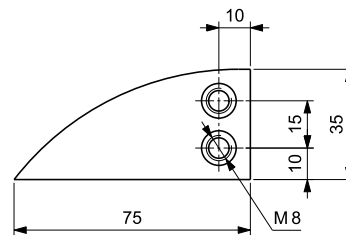

On request, Upper part is available in Self-Lubricating UHMWPE & Oil-filled PA.



CURVES	PART NUMBER IDENTIFICATION		
UPPER PART MATERIAL	UHMWPE	Self-lubricating UHMWPE	Oil-filled PA
PART NUMBERS	See table below	Replace "MH" with "MHD" Example: 1 track, 90° curve angle, P/N: MHD01GAW/600	Replace "MH" with "MHP" Example: 1 track, 90° curve angle, P/N: MHP01GAW/600



Curve installation see page 280



Curve material see page 279

N. OF TRACKS	TOTAL WIDTH W mm	PART NUMBER					
		Curve angle $\alpha$					
		15°	30°	45°	60°	75°	90°
1	214	MH01GFW/600	MH01GEW/600	MH01GCW/600	MH01GBW/600	MH01GLW/600	MH01GAW/600

NOTE: For custom requests with dimensions different from the standard, please refer to page 319.

## VERSION H 05

### SUITABLE FOR CHAINS:

- 882M K 10 (See page 61)
- HFX 882M K 10 (See page 70)

RADIUS mm	BASIC WIDTH mm	TRANSVERSAL PITCH mm	INFEEED/ OUTFEED LENGTH mm
860	290	Single track	-

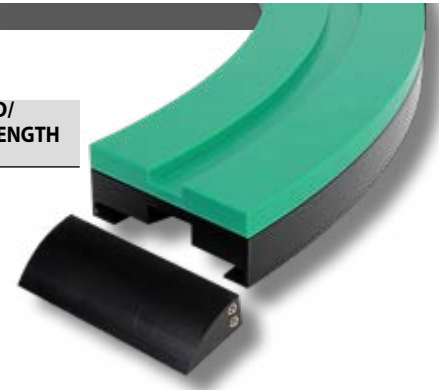

Single track

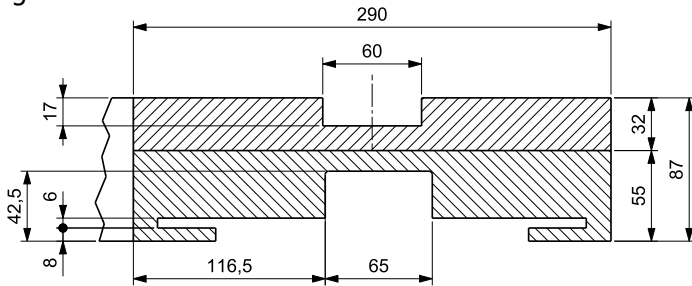

Radius

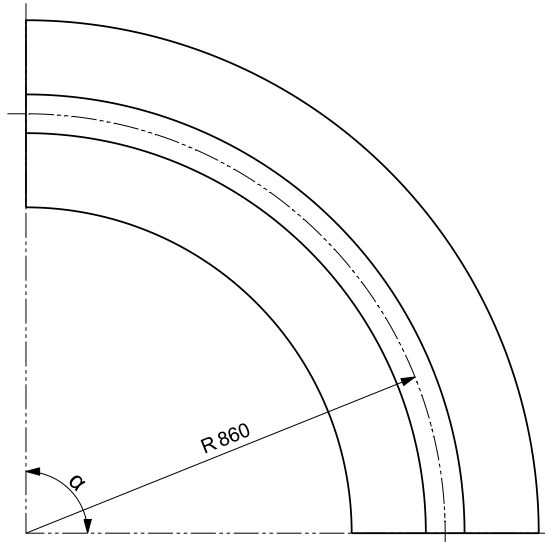

Return guide shoe

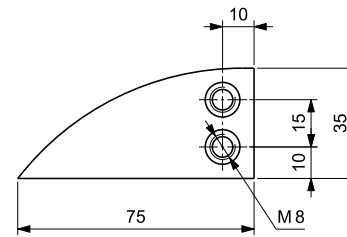

On request, Upper part is available in Self-Lubricating UHMWPE & Oil-filled PA.



CURVES	PART NUMBER IDENTIFICATION		
	SUPREME - A	SUPREME - L	SUPREME - S
UPPER PART MATERIAL	UHMWPE	Self-lubricating UHMWPE	Oil-filled PA
PART NUMBERS	See table below	Replace "MH" with "MHD" Example: 1 track, 90° curve angle, P/N: MHD01FAW/L00	Replace "MH" with "MHP" Example: 1 track, 90° curve angle, P/N: MHP01FAW/L00

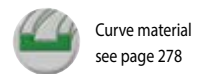
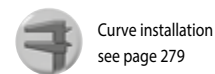

N. OF TRACKS	TOTAL WIDTH W mm	PART NUMBER					
		Curve angle $\alpha$					
		15°	30°	45°	60°	75°	90°
1	290	MH01FFW/L00	MH01FEW/L00	MH01FCW/L00	MH01FBW/L00	MH01FLW/L00	MH01FAW/L00

NOTE: For custom requests with dimensions different from the standard, please refer to page 318.



## VERSION H 06

### SUITABLE FOR CHAINS:

- 882M K 12 (See page 61)
- HFX 882M K 12 (See page 70)

RADIUS mm	BASIC WIDTH mm	TRANSVERSAL PITCH mm	INFEED/ OUTFEED LENGTH mm
860	340	Single track	-

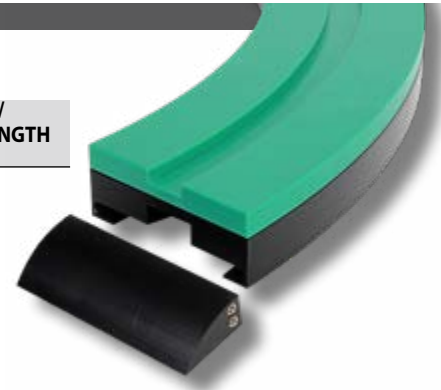

Single track

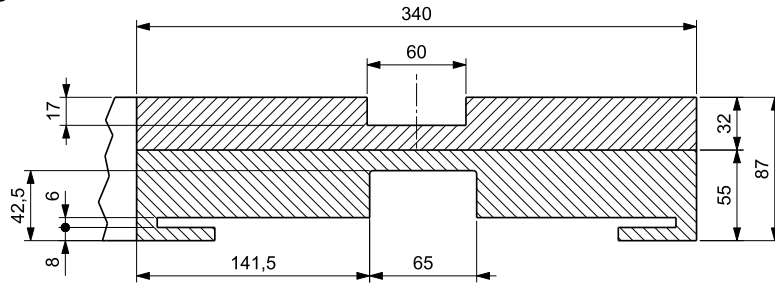

Radius

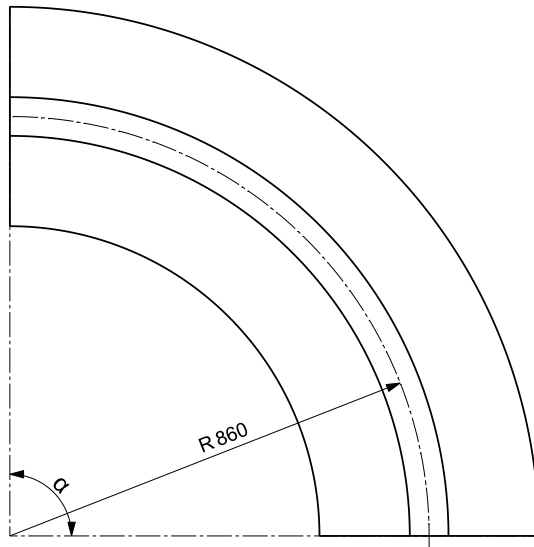

Return guide shoe

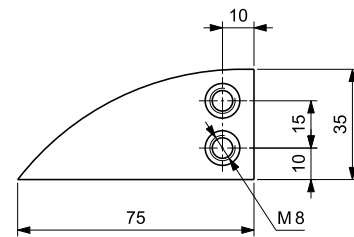

On request, Upper part is available in Self-Lubricating UHMWPE & Oil-filled PA.



PART NUMBER IDENTIFICATION			
CURVES			
UPPER PART MATERIAL	UHMWPE	Self-lubricating UHMWPE	Oil-filled PA
PART NUMBERS	See table below	Replace "MH" with "MHD" Example: 1 track, 90° curve angle, P/N: MHD01FAW/J00	Replace "MH" with "MHP" Example: 1 track, 90° curve angle, P/N: MHP01FAW/J00



Curve installation see page 279



Curve material see page 278

N. OF TRACKS	TOTAL WIDTH W mm	PART NUMBER					
		Curve angle $\alpha$					
		15°	30°	45°	60°	75°	90°
1	340	MH01FFW/J00	MH01FEW/J00	MH01FCW/J00	MH01FBW/J00	MH01FLW/J00	MH01FAW/J00

NOTE: For custom requests with dimensions different from the standard, please refer to page 318.

## VERSION L 01

SUITABLE FOR CHAINS:

- LBP 882M K 7½

(See page 108)

RADIUS mm	BASIC WIDTH mm	TRANSVERSAL PITCH mm	INFEEED/ OUTFEED LENGTH mm
860	214	Single track	-

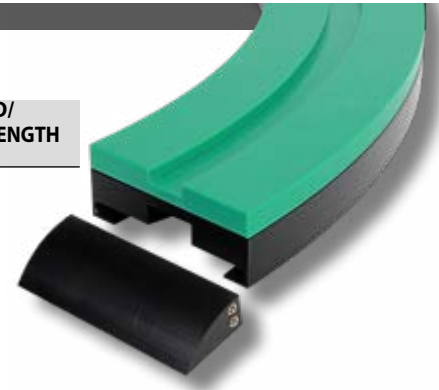

Single track

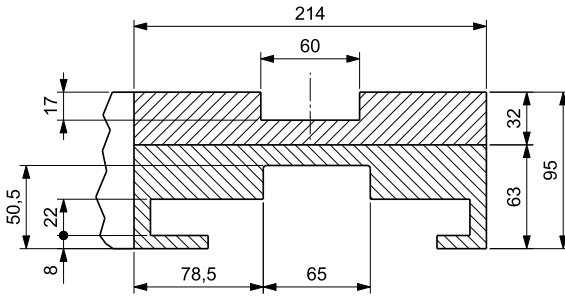

Radius

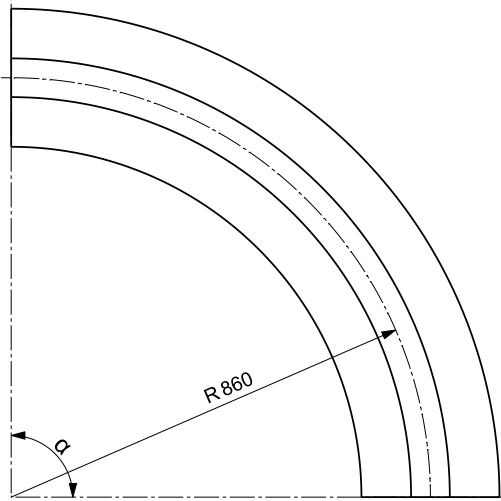

Return guide shoe

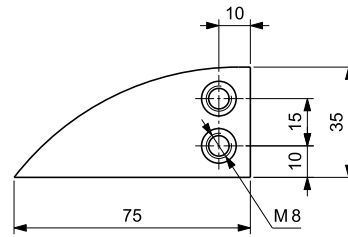

On request, Upper part is available in Self-Lubricating UHMWPE & Oil-filled PA.



CURVES	PART NUMBER IDENTIFICATION		
	SUPREME - A	SUPREME - L	SUPREME - S
UPPER PART MATERIAL	UHMWPE	Self-lubricating UHMWPE	Oil-filled PA
PART NUMBERS	See table below	Replace "ML" with "MLD" Example: 1 track, 90° curve angle, P/N: MLD01FAZ/600	Replace "ML" with "MLP" Example: 1 track, 90° curve angle, P/N: MLP01FAZ/600



Curve installation see page 279



Curve material see page 278

N. OF TRACKS	TOTAL WIDTH W mm	PART NUMBER					
		Curve angle α					
		15°	30°	45°	60°	75°	90°
1	214	ML01FFZ/600	ML01FEZ/600	ML01FCZ/600	ML01FBZ/600	ML01FLZ/600	ML01FAZ/600

NOTE: For custom requests with dimensions different from the standard, please refer to page 318.

## VERSION L 02

SUITABLE FOR CHAINS:

- LBP 882M K 10

(See page 108)

RADIUS mm	BASIC WIDTH mm	TRANSVERSAL PITCH mm	INFEEED/ OUTFEED LENGTH mm
860	290	Single track	-

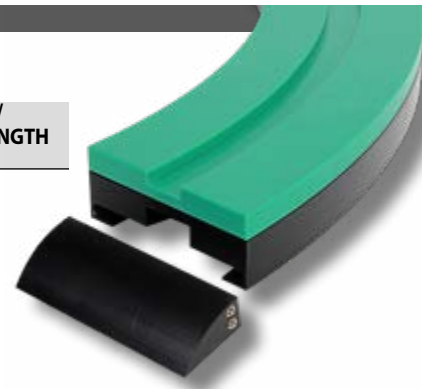

Single track

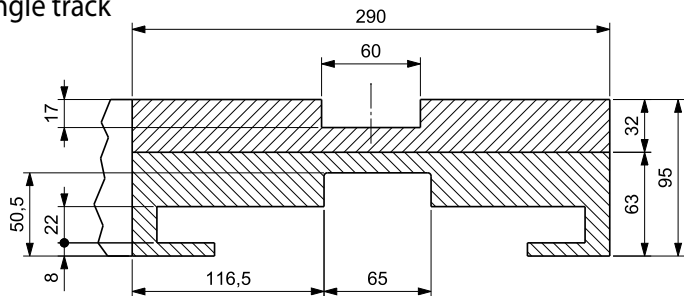

Radius

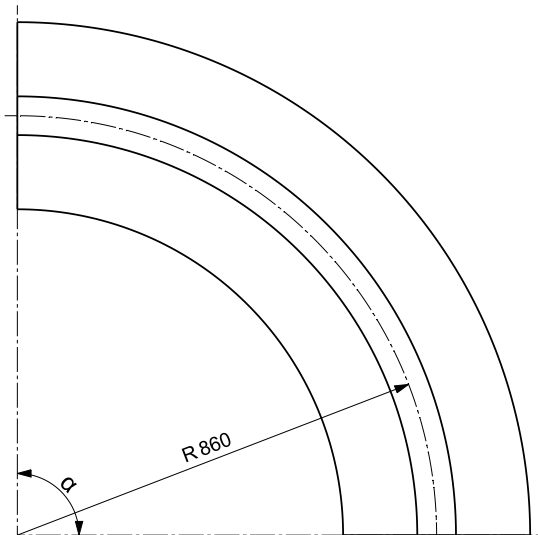

Return guide shoe

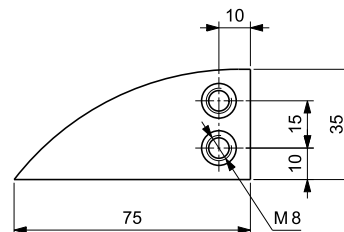

On request, Upper part is available in Self-Lubricating UHMWPE & Oil-filled PA.



CURVES	PART NUMBER IDENTIFICATION		
UPPER PART MATERIAL	UHMWPE	Self-lubricating UHMWPE	Oil-filled PA
PART NUMBERS	See table below	Replace "ML" with "MLD" Example: 1 track, 90° curve angle, P/N: MLD01FAZ/L00	Replace "ML" with "MLP" Example: 1 track, 90° curve angle, P/N: MLP01FAZ/L00



Curve installation see page 279



Curve material see page 278

N. OF TRACKS	TOTAL WIDTH W mm	PART NUMBER					
		Curve angle $\alpha$					
		15°	30°	45°	60°	75°	90°
1	290	ML01FFZ/L00	ML01FEZ/L00	ML01FCZ/L00	ML01FBZ/L00	ML01FLZ/L00	ML01FAZ/L00

NOTE: For custom requests with dimensions different from the standard, please refer to page 318.

## VERSION L 03

SUITABLE FOR CHAINS:

- LBP 882M K 12

(See page 108)

RADIUS mm	BASIC WIDTH mm	TRANSVERSAL PITCH mm	INFEEED/ OUTFEED LENGTH mm
860	340	Single track	-

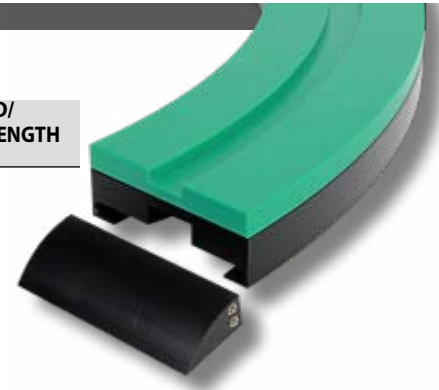

Single track

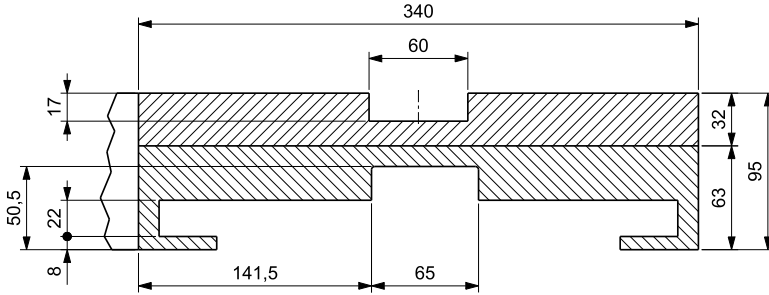

Radius

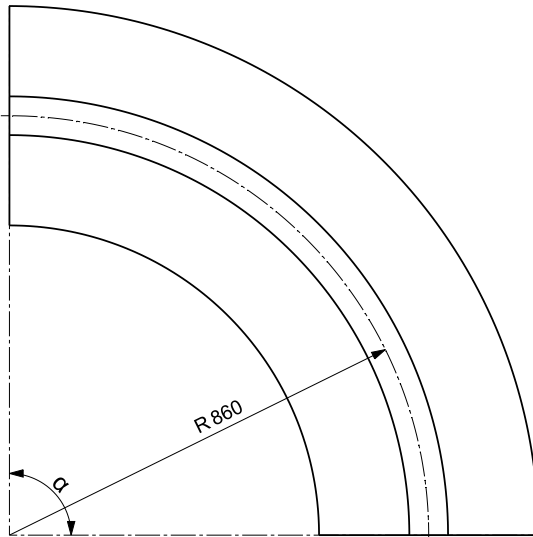

Return guide shoe

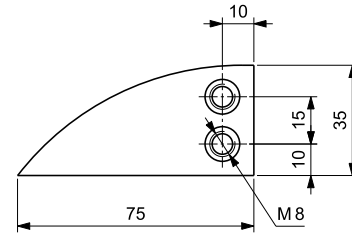

On request, Upper part is available in Self-Lubricating UHMWPE & Oil-filled PA.



CURVES	PART NUMBER IDENTIFICATION		
	SUPREME -A	SUPREME -L	SUPREME -S
UPPER PART MATERIAL	UHMWPE	Self-lubricating UHMWPE	Oil-filled PA
PART NUMBERS	See table below	Replace "ML" with "MLD" Example: 1 track, 90° curve angle, P/N: MLD01FAZ/J00	Replace "ML" with "MLP" Example: 1 track, 90° curve angle, P/N: MLP01FAZ/J00



Curve installation see page 279



Curve material see page 278

N. OF TRACKS	TOTAL WIDTH W mm	PART NUMBER					
		Curve angle $\alpha$					
		15°	30°	45°	60°	75°	90°
1	340	ML01FFZ/J00	ML01FEZ/J00	ML01FCZ/J00	ML01FBZ/J00	ML01FLZ/J00	ML01FAZ/J00

NOTE: For custom requests with dimensions different from the standard, please refer to page 318.

## VERSION M 01

### SUITABLE FOR CHAINS:

- 782M K 83,8 (See page 247)
- 783M K 83,8 (See page 247)

RADIUS	BASIC WIDTH	TRANSVERSAL PITCH	INFEED/OUTFEED LENGTH
mm	mm	mm	mm
500	100	85	-



Single track

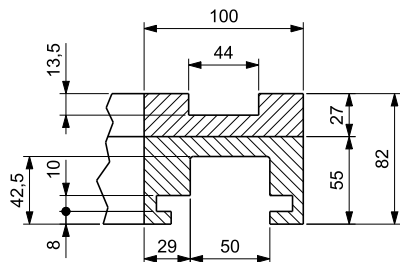

Multi track

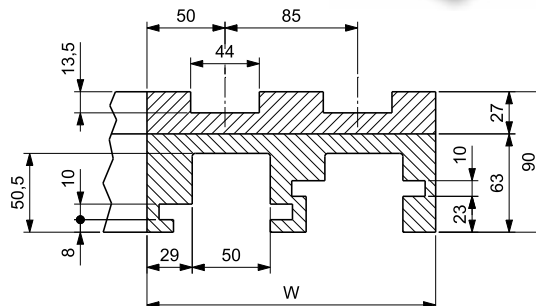

Radius

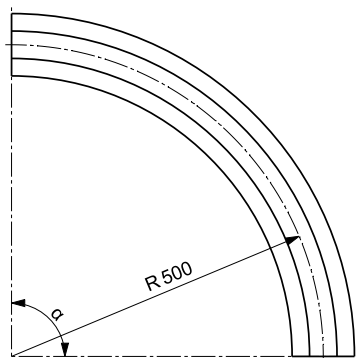

Return guide shoe

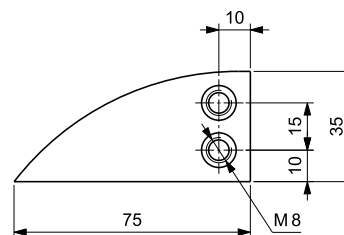

On request, Upper part is available in Self-Lubricating UHMWPE & Oil-filled PA.



CURVES	PART NUMBER IDENTIFICATION		
	SUPREME -A	SUPREME -L	SUPREME -S
UPPER PART MATERIAL	UHMWPE	Self-lubricating UHMWPE	Oil-filled PA
PART NUMBERS	See table below	Replace "MM" with "MMD" Example: 2 tracks, 90° curve angle, P/N: MMD02AAY/110	Replace "MM" with "MMP" Example: 2 tracks, 90° curve angle, P/N: MMP02AAY/110



Curve installation see page 279



Curve material see page 278

N. OF TRACKS	TOTAL WIDTH W mm	PART NUMBER					
		Curve angle $\alpha$					
		15°	30°	45°	60°	75°	90°
1	100	MM01AFX/100	MM01AEX/100	MM01ACX/100	MM01ABX/100	MM01ALX/100	MM01AAX/100
2	185	MM02AFY/110	MM02AEY/110	MM02ACY/110	MM02ABY/110	MM02ALY/110	MM02AAY/110
3	270	MM03AFY/110	MM03AEY/110	MM03ACY/110	MM03ABY/110	MM03ALY/110	MM03AAY/110
4	355	MM04AFY/110	MM04AEY/110	MM04ACY/110	MM04ABY/110	MM04ALY/110	MM04AAY/110
5	440	MM05AFY/110	MM05AEY/110	MM05ACY/110	MM05ABY/110	MM05ALY/110	MM05AAY/110
6	525	MM06AFY/110	MM06AEY/110	MM06ACY/110	MM06ABY/110	MM06ALY/110	MM06AAY/110

NOTE: For custom requests with dimensions different from the standard, please refer to page 318.

## VERSION M 02

### SUITABLE FOR CHAINS:

- 782M K 83,8 (See page 247)
- 783M K 83,8 (See page 247)

RADIUS	BASIC WIDTH	TRANSVERSAL PITCH	INFEEED/OUTFEED LENGTH
mm	mm	mm	mm
500	100	85	100



Single track

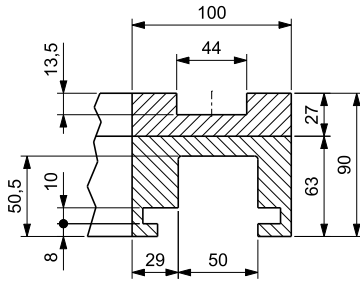

Multi track

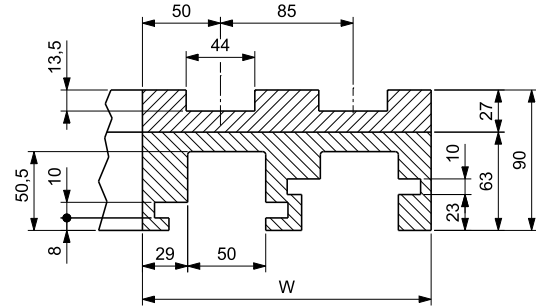

Radius

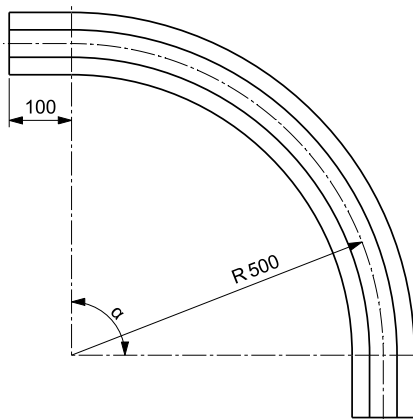

Return guide shoe

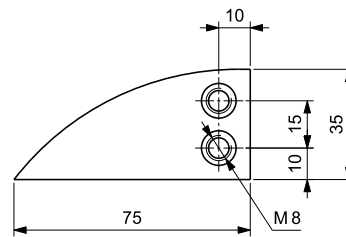

On request, Upper part is available in Self-Lubricating UHMWPE & Oil-filled PA.



CURVES	PART NUMBER IDENTIFICATION		
	SUPREME -A	SUPREME -L	SUPREME -S
UPPER PART MATERIAL	UHMWPE	Self-lubricating UHMWPE	Oil-filled PA
PART NUMBERS	See table below	Replace "MM" with "MMD" Example: 2 tracks, 90° curve angle, P/N: MMD02AAY/111	Replace "MM" with "MMP" Example: 2 tracks, 90° curve angle, P/N: MMP02AAY/111

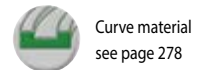
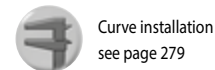

N. OF TRACKS	TOTAL WIDTH W mm	PART NUMBER					
		Curve angle $\alpha$					
		15°	30°	45°	60°	75°	90°
1	100	MM01AFY/101	MM01AEY/101	MM01ACY/101	MM01ABY/101	MM01ALY/101	MM01AAY/101
2	185	MM02AFY/111	MM02AEY/111	MM02ACY/111	MM02ABY/111	MM02ALY/111	MM02AAY/111
3	270	MM03AFY/111	MM03AEY/111	MM03ACY/111	MM03ABY/111	MM03ALY/111	MM03AAY/111
4	355	MM04AFY/111	MM04AEY/111	MM04ACY/111	MM04ABY/111	MM04ALY/111	MM04AAY/111
5	440	MM05AFY/111	MM05AEY/111	MM05ACY/111	MM05ABY/111	MM05ALY/111	MM05AAY/111
6	525	MM06AFY/111	MM06AEY/111	MM06ACY/111	MM06ABY/111	MM06ALY/111	MM06AAY/111

NOTE: For custom requests with dimensions different from the standard, please refer to page 318.



## VERSION M 03

### SUITABLE FOR CHAINS:

- 782M K 83,8 (See page 247)
- 783M K 83,8 (See page 247)

RADIUS mm	BASIC WIDTH mm	TRANSVERSAL PITCH mm	INFEED/ OUTFEED LENGTH mm
500	111	85	100



Single track

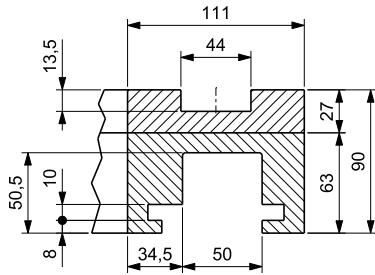

Multi track

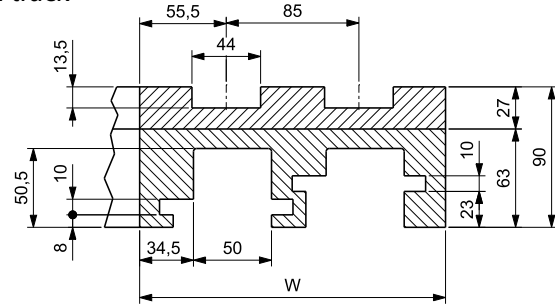

Radius

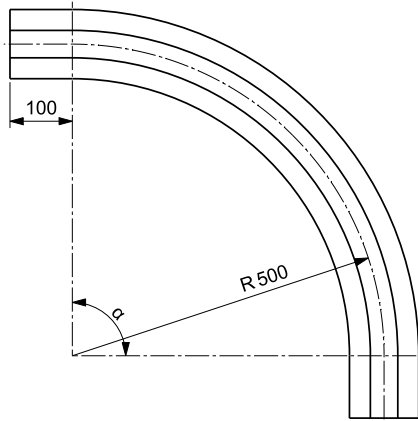

Return guide shoe

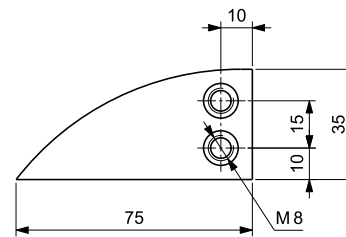

On request, Upper part is available in Self-Lubricating UHMWPE & Oil-filled PA.



CURVES	PART NUMBER IDENTIFICATION		
	SUPREME -A	SUPREME -L	SUPREME -S
UPPER PART MATERIAL	UHMWPE	Self-lubricating UHMWPE	Oil-filled PA
PART NUMBERS	See table below	Replace "MM" with "MMD" Example: 2 tracks, 90° curve angle, P/N: MMD02AAY/311	Replace "MM" with "MMP" Example: 2 tracks, 90° curve angle, P/N: MMP02AAY/311



Curve installation see page 279



Curve material see page 278

N. OF TRACKS	TOTAL WIDTH W mm	PART NUMBER					
		Curve angle $\alpha$					
		15°	30°	45°	60°	75°	90°
1	111	MM01AFY/301	MM01AEY/301	MM01ACY/301	MM01ABY/301	MM01ALY/301	MM01AAY/301
2	196	MM02AFY/311	MM02AEY/311	MM02ACY/311	MM02ABY/311	MM02ALY/311	MM02AAY/311
3	281	MM03AFY/311	MM03AEY/311	MM03ACY/311	MM03ABY/311	MM03ALY/311	MM03AAY/311
4	366	MM04AFY/311	MM04AEY/311	MM04ACY/311	MM04ABY/311	MM04ALY/311	MM04AAY/311
5	451	MM05AFY/311	MM05AEY/311	MM05ACY/311	MM05ABY/311	MM05ALY/311	MM05AAY/311
6	536	MM06AFY/311	MM06AEY/311	MM06ACY/311	MM06ABY/311	MM06ALY/311	MM06AAY/311

NOTE: For custom requests with dimensions different from the standard, please refer to page 318.

## VERSION M 04

### SUITABLE FOR CHAINS:

- 782M K 83,8 (See page 247)
- 783M K 83,8 (See page 247)

RADIUS	BASIC WIDTH	TRANSVERSAL PITCH	INFEEED/OUTFEED LENGTH
mm	mm	mm	mm
750	100	85	100



Single track

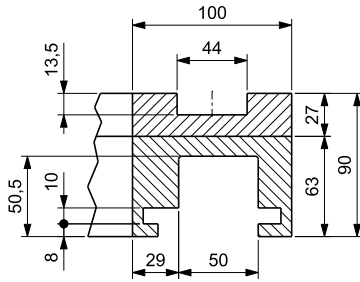

Multi track

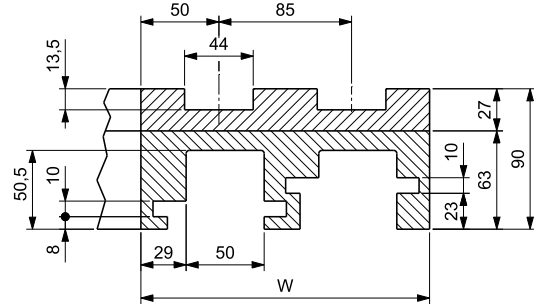

Radius

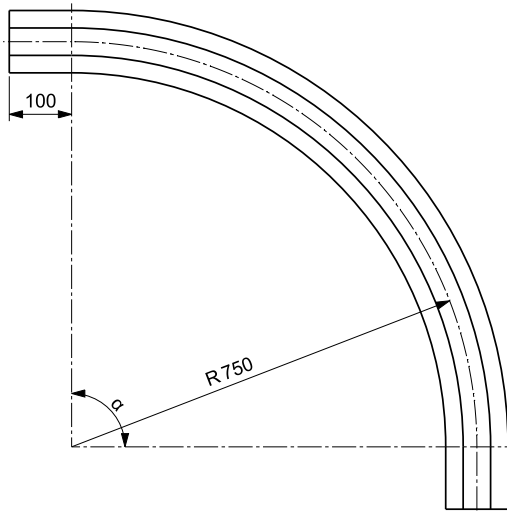

Return guide shoe

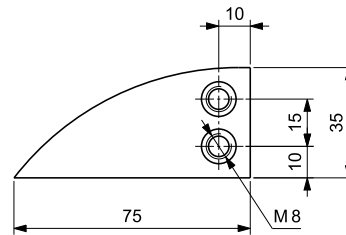

On request, Upper part is available in Self-Lubricating UHMWPE & Oil-filled PA.



PART NUMBER IDENTIFICATION			
CURVES			
UPPER PART MATERIAL	UHMWPE	Self-lubricating UHMWPE	Oil-filled PA
PART NUMBERS	See table below	Replace "MM" with "MMD" Example: 2 tracks, 90° curve angle, P/N: MMD02EAY/111	Replace "MM" with "MMP" Example: 2 tracks, 90° curve angle, P/N: MMP02EAY/111

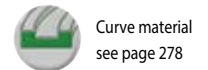
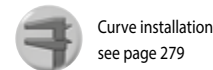

N. OF TRACKS	TOTAL WIDTH W mm	PART NUMBER					
		Curve angle $\alpha$					
		15°	30°	45°	60°	75°	90°
1	100	MM01EFY/101	MM01EEY/101	MM01ECY/101	MM01EBY/101	MM01ELY/101	MM01EAY/101
2	185	MM02EFY/111	MM02EEY/111	MM02ECY/111	MM02EBY/111	MM02ELY/111	MM02EAY/111
3	270	MM03EFY/111	MM03EEY/111	MM03ECY/111	MM03EBY/111	MM03ELY/111	MM03EAY/111
4	355	MM04EFY/111	MM04EEY/111	MM04ECY/111	MM04EBY/111	MM04ELY/111	MM04EAY/111
5	440	MM05EFY/111	MM05EEY/111	MM05ECY/111	MM05EBY/111	MM05ELY/111	MM05EAY/111
6	525	MM06EFY/111	MM06EEY/111	MM06ECY/111	MM06EBY/111	MM06ELY/111	MM06EAY/111

NOTE: For custom requests with dimensions different from the standard, please refer to page 318.

## VERSION M 05

### SUITABLE FOR CHAINS:

- 782M K 83,8 (See page 247)
- 783M K 83,8 (See page 247)

RADIUS mm	BASIC WIDTH mm	TRANSVERSAL PITCH mm	INFEED/ OUTFEED LENGTH mm
750	111	85	100



Single track

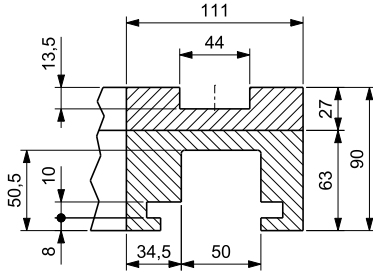

Multi track

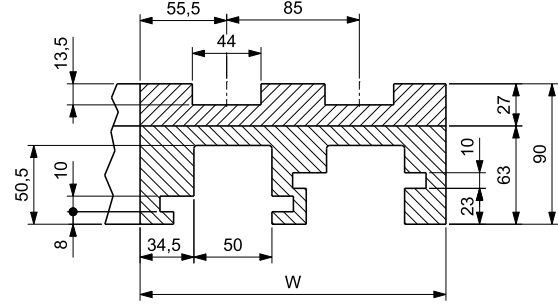

Radius

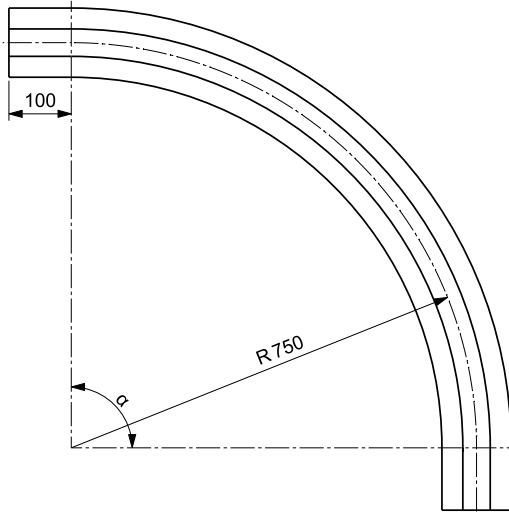

Return guide shoe

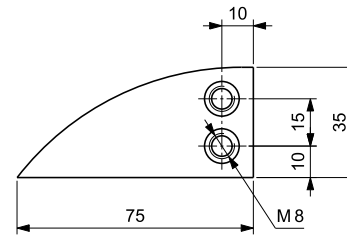

On request, Upper part is available in Self-Lubricating UHMWPE & Oil-filled PA.



CURVES	PART NUMBER IDENTIFICATION		
	SUPREME -A	SUPREME -L	SUPREME -S
UPPER PART MATERIAL	UHMWPE	Self-lubricating UHMWPE	Oil-filled PA
PART NUMBERS	See table below	Replace "MM" with "MMD" Example: 2 tracks, 90° curve angle, P/N: MMD02EAY/311	Replace "MM" with "MMP" Example: 2 tracks, 90° curve angle, P/N: MMP02EAY/311



Curve installation see page 279



Curve material see page 278

N. OF TRACKS	TOTAL WIDTH W mm	PART NUMBER					
		Curve angle $\alpha$					
		15°	30°	45°	60°	75°	90°
1	111	MM01EFY/301	MM01EEY/301	MM01ECY/301	MM01EBY/301	MM01ELY/301	MM01EAY/301
2	196	MM02EFY/311	MM02EEY/311	MM02ECY/311	MM02EBY/311	MM02ELY/311	MM02EAY/311
3	281	MM03EFY/311	MM03EEY/311	MM03ECY/311	MM03EBY/311	MM03ELY/311	MM03EAY/311
4	366	MM04EFY/311	MM04EEY/311	MM04ECY/311	MM04EBY/311	MM04ELY/311	MM04EAY/311
5	451	MM05EFY/311	MM05EEY/311	MM05ECY/311	MM05EBY/311	MM05ELY/311	MM05EAY/311
6	536	MM06EFY/311	MM06EEY/311	MM06ECY/311	MM06EBY/311	MM06ELY/311	MM06EAY/311

NOTE: For custom requests with dimensions different from the standard, please refer to page 318.

## VERSION M 06

### SUITABLE FOR CHAINS:

- 782M K 83,8 (See page 247)
- 783M K 83,8 (See page 247)

RADIUS	BASIC WIDTH	TRANSVERSAL PITCH	INFEED/ OUTFEED LENGTH
mm	mm	mm	mm
1000	100	85	-



Single track

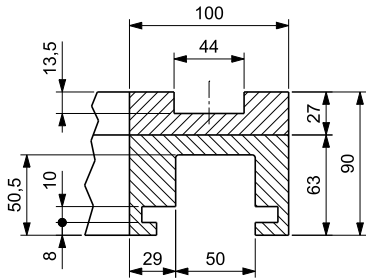

Multi track

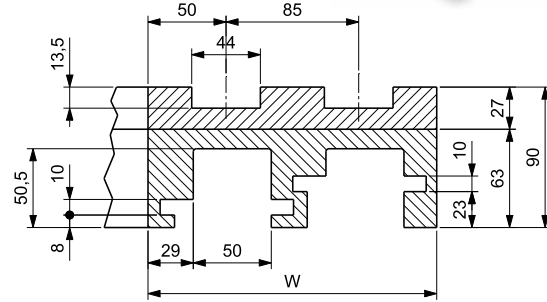

Radius

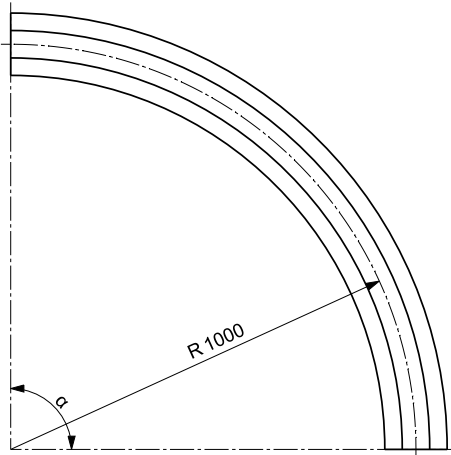

Return guide shoe

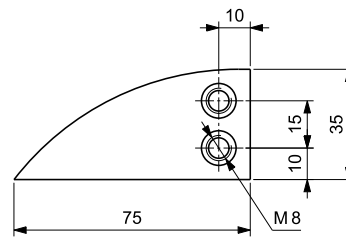

On request, Upper part is available in Self-Lubricating UHMWPE & Oil-filled PA.



CURVES	PART NUMBER IDENTIFICATION		
	SUPREME -A	SUPREME -L	SUPREME -S
UPPER PART MATERIAL	UHMWPE	Self-lubricating UHMWPE	Oil-filled PA
PART NUMBERS	See table below	Replace "MM" with "MMD" Example: 2 tracks, 90° curve angle, P/N: MMD02GAY/110	Replace "MM" with "MMP" Example: 2 tracks, 90° curve angle, P/N: MMP02GAY/110



Curve installation see page 279



Curve material see page 278

N. OF TRACKS	TOTAL WIDTH W mm	PART NUMBER					
		Curve angle $\alpha$					
		15°	30°	45°	60°	75°	90°
1	100	MM01GFY/100	MM01GEY/100	MM01GKY/100	MM01GBY/100	MM01GLY/100	MM01GAY/100
2	185	MM02GFY/110	MM02GEY/110	MM02GKY/110	MM02GBY/110	MM02GLY/110	MM02GAY/110
3	270	MM03GFY/110	MM03GEY/110	MM03GKY/110	MM03GBY/110	MM03GLY/110	MM03GAY/110
4	355	MM04GFY/110	MM04GEY/110	MM04GKY/110	MM04GBY/110	MM04GLY/110	MM04GAY/110

NOTE: For custom requests with dimensions different from the standard, please refer to page 318.

## VERSION U 01

SUITABLE FOR CHAINS:  
-793M K 83,8

(See page 249)

RADIUS mm	BASIC WIDTH mm	TRANSVERSAL PITCH mm	INFEED/ OUTFEED LENGTH mm
500	100	85	-



Single track

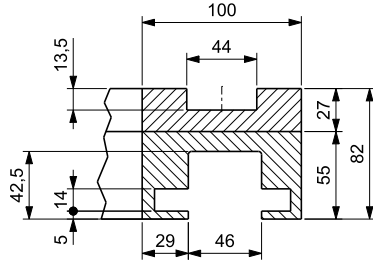

Multi track

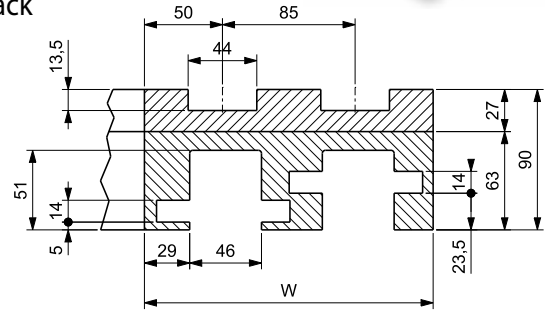

Radius

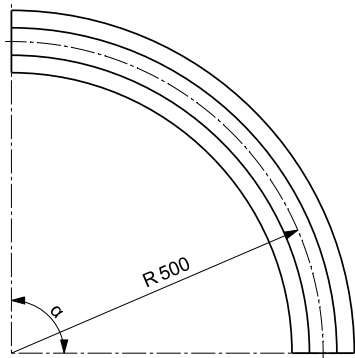

Return guide shoe

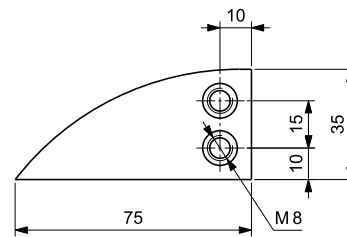

On request, Upper part is available in Self-Lubricating UHMWPE & Oil-filled PA.



PART NUMBER IDENTIFICATION			
CURVES	SUPREME -A	SUPREME -L	SUPREME -S
UPPER PART MATERIAL	UHMWPE	Self-lubricating UHMWPE	Oil-filled PA
PART NUMBERS	See table below	Replace "MU" with "MUD" Example: 2 tracks, 90° curve angle, P/N: MUD02AAY/110	Replace "MU" with "MUP" Example: 2 tracks, 90° curve angle, P/N: MUP02AAY/110



Curve installation  
see page 279



Curve material  
see page 278

N. OF TRACKS	TOTAL WIDTH W mm	PART NUMBER					
		Curve angle $\alpha$					
		15°	30°	45°	60°	75°	90°
1	100	MU01AFX/100	MU01AEX/100	MU01ACX/100	MU01ABX/100	MU01ALX/100	MU01AAX/100
2	185	MU02AFY/110	MU02AEY/110	MU02ACY/110	MU02ABY/110	MU02ALY/110	MU02AAY/110
3	270	MU03AFY/110	MU03AEY/110	MU03ACY/110	MU03ABY/110	MU03ALY/110	MU03AAY/110
4	355	MU04AFY/110	MU04AEY/110	MU04ACY/110	MU04ABY/110	MU04ALY/110	MU04AAY/110
5	440	MU05AFY/110	MU05AEY/110	MU05ACY/110	MU05ABY/110	MU05ALY/110	MU05AAY/110
6	525	MU06AFY/110	MU06AEY/110	MU06ACY/110	MU06ABY/110	MU06ALY/110	MU06AAY/110

NOTE: For custom requests with dimensions different from the standard, please refer to page 318.

## VERSION U 02

SUITABLE FOR CHAINS:  
-793M K 83,8

(See page 249)

RADIUS mm	BASIC WIDTH mm	TRANSVERSAL PITCH mm	INFEEED/ OUTFEED LENGTH mm
500	100	85	100



Single track

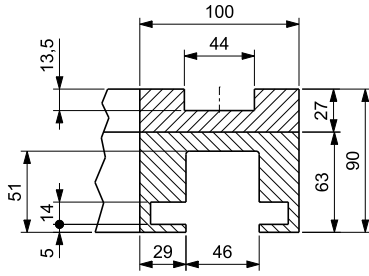

Multi track

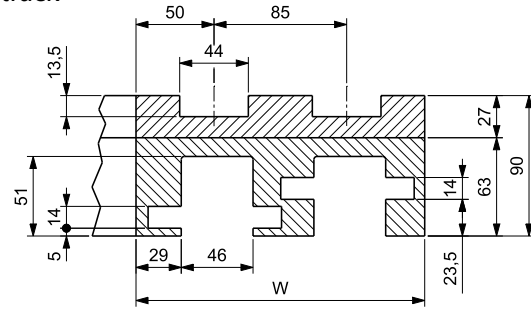

Radius

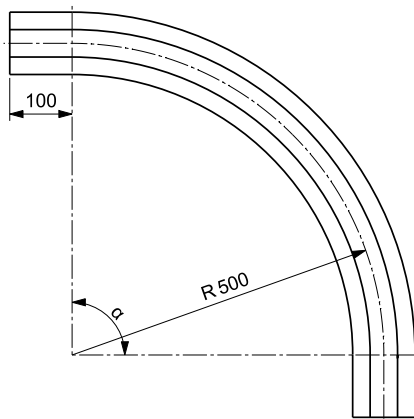

Return guide shoe

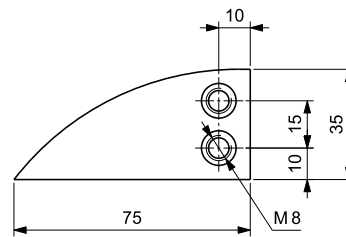

On request, Upper part is available in Self-Lubricating UHMWPE & Oil-filled PA.



CURVES	PART NUMBER IDENTIFICATION		
	SUPREME -A	SUPREME -L	SUPREME -S
UPPER PART MATERIAL	UHMWPE	Self-lubricating UHMWPE	Oil-filled PA
PART NUMBERS	See table below	Replace "MU" with "MUD" Example: 2 tracks, 90° curve angle, P/N: MUD02AAY/111	Replace "MU" with "MUP" Example: 2 tracks, 90° curve angle, P/N: MUP02AAY/111

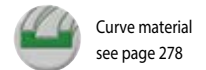
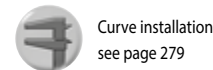

N. OF TRACKS	TOTAL WIDTH W mm	PART NUMBER					
		Curve angle α					
		15°	30°	45°	60°	75°	90°
1	100	MU01AFY/101	MU01AEY/101	MU01ACY/101	MU01ABY/101	MU01ALY/101	MU01AAY/101
2	185	MU02AFY/111	MU02AEY/111	MU02ACY/111	MU02ABY/111	MU02ALY/111	MU02AAY/111
3	270	MU03AFY/111	MU03AEY/111	MU03ACY/111	MU03ABY/111	MU03ALY/111	MU03AAY/111
4	355	MU04AFY/111	MU04AEY/111	MU04ACY/111	MU04ABY/111	MU04ALY/111	MU04AAY/111
5	440	MU05AFY/111	MU05AEY/111	MU05ACY/111	MU05ABY/111	MU05ALY/111	MU05AAY/111
6	525	MU06AFY/111	MU06AEY/111	MU06ACY/111	MU06ABY/111	MU06ALY/111	MU06AAY/111

NOTE: For custom requests with dimensions different from the standard, please refer to page 318.



## VERSION U 03

SUITABLE FOR CHAINS:  
-793M K 83,8

(See page 249)

RADIUS mm	BASIC WIDTH mm	TRANSVERSAL PITCH mm	INFEEED/ OUTFEED LENGTH mm
500	111	85	100



Single track

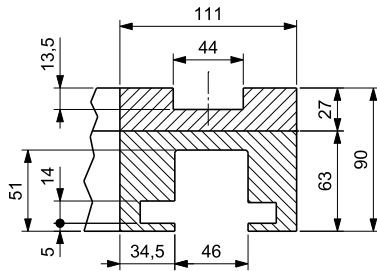

Multi track

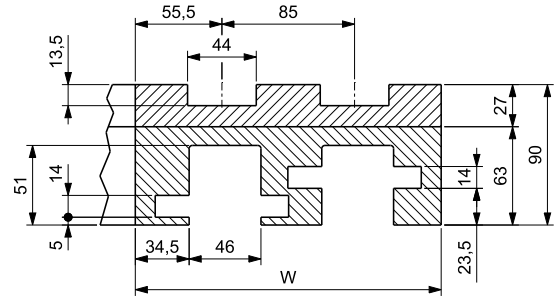

Radius

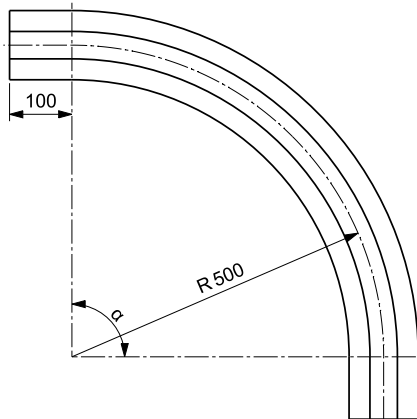

Return guide shoe

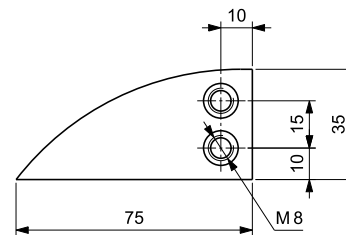

On request, Upper part is available in Self-Lubricating UHMWPE & Oil-filled PA.



CURVES	PART NUMBER IDENTIFICATION		
UPPER PART MATERIAL	UHMWPE	Self-lubricating UHMWPE	Oil-filled PA
PART NUMBERS	See table below	Replace "MU" with "MUD" Example: 2 tracks, 90° curve angle, P/N: MUD02AAAY/311	Replace "MU" with "MUP" Example: 2 tracks, 90° curve angle, P/N: MUP02AAAY/311



Curve installation  
see page 279



Curve material  
see page 278

N. OF TRACKS	TOTAL WIDTH W mm	PART NUMBER					
		Curve angle $\alpha$					
		15°	30°	45°	60°	75°	90°
1	111	MU01AFY/301	MU01AEY/301	MU01ACY/301	MU01ABY/301	MU01ALY/301	MU01AAY/301
2	196	MU02AFY/311	MU02AEY/311	MU02ACY/311	MU02ABY/311	MU02ALY/311	MU02AAY/311
3	281	MU03AFY/311	MU03AEY/311	MU03ACY/311	MU03ABY/311	MU03ALY/311	MU03AAY/311
4	366	MU04AFY/311	MU04AEY/311	MU04ACY/311	MU04ABY/311	MU04ALY/311	MU04AAY/311
5	451	MU05AFY/311	MU05AEY/311	MU05ACY/311	MU05ABY/311	MU05ALY/311	MU05AAY/311
6	536	MU06AFY/311	MU06AEY/311	MU06ACY/311	MU06ABY/311	MU06ALY/311	MU06AAY/311

NOTE: For custom requests with dimensions different from the standard, please refer to page 318.

## VERSION U 04

SUITABLE FOR CHAINS:  
- 793M K 83,8

(See page 249)

RADIUS mm	BASIC WIDTH mm	TRANSVERSAL PITCH mm	INFEED/ OUTFEED LENGTH mm
750	100	85	100



Single track

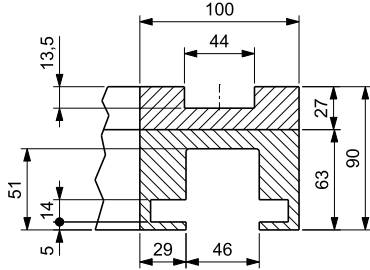

Multi track

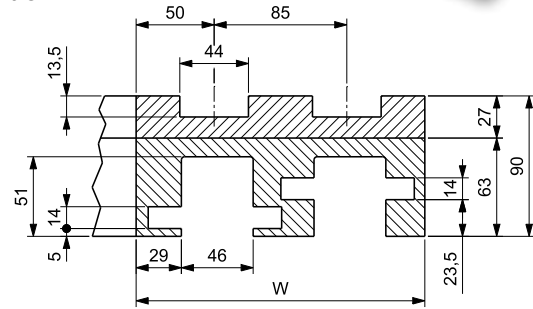

Radius

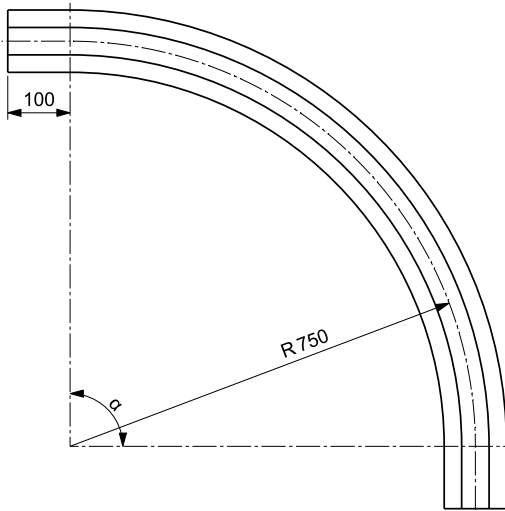

Return guide shoe

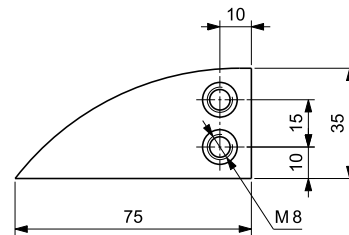

On request, Upper part is available in Self-Lubricating UHMWPE & Oil-filled PA.



CURVES	PART NUMBER IDENTIFICATION		
	SUPREME -A	SUPREME -L	SUPREME -S
UPPER PART MATERIAL	UHMWPE	Self-lubricating UHMWPE	Oil-filled PA
PART NUMBERS	See table below	Replace "MU" with "MUD" Example: 2 tracks, 90° curve angle, P/N: MUD02EAY/111	Replace "MU" with "MUP" Example: 2 tracks, 90° curve angle, P/N: MUP02EAY/111



Curve installation see page 279



Curve material see page 278

N. OF TRACKS	TOTAL WIDTH W mm	PART NUMBER					
		Curve angle $\alpha$					
		15°	30°	45°	60°	75°	90°
1	100	MU01EFY/101	MU01EEY/101	MU01ECY/101	MU01EBY/101	MU01ELY/101	MU01EAY/101
2	185	MU02EFY/111	MU02EEY/111	MU02ECY/111	MU02EBY/111	MU02ELY/111	MU02EAY/111
3	270	MU03EFY/111	MU03EEY/111	MU03ECY/111	MU03EBY/111	MU03ELY/111	MU03EAY/111
4	355	MU04EFY/111	MU04EEY/111	MU04ECY/111	MU04EBY/111	MU04ELY/111	MU04EAY/111
5	440	MU05EFY/111	MU05EEY/111	MU05ECY/111	MU05EBY/111	MU05ELY/111	MU05EAY/111
6	525	MU06EFY/111	MU06EEY/111	MU06ECY/111	MU06EBY/111	MU06ELY/111	MU06EAY/111

NOTE: For custom requests with dimensions different from the standard, please refer to page 318.

## VERSION U 05

SUITABLE FOR CHAINS:

- 793M K 83,8

(See page 249)

RADIUS mm	BASIC WIDTH mm	TRANSVERSAL PITCH mm	INFEED/ OUTFEED LENGTH mm
1000	100	85	-



Single track

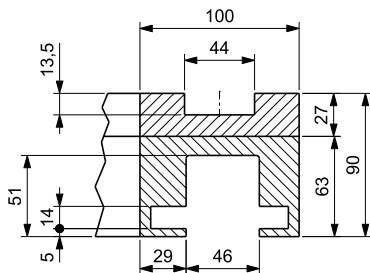

Multi track

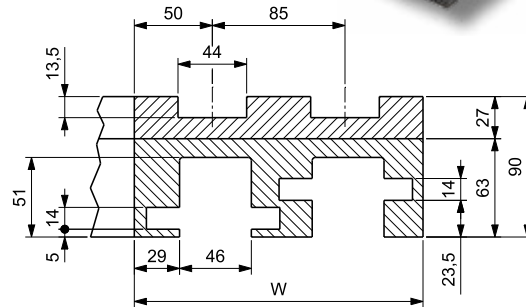

Radius

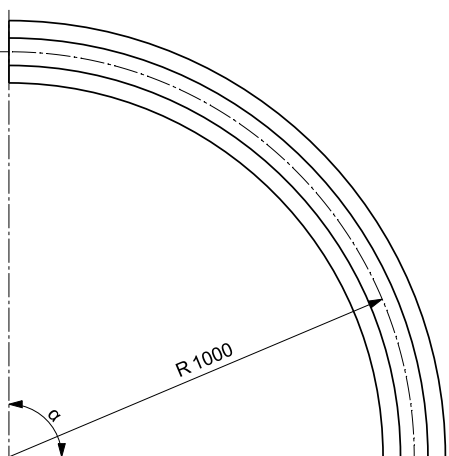

Return guide shoe

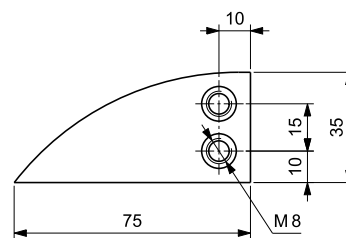

On request, Upper part is available in Self-Lubricating UHMWPE & Oil-filled PA.



CURVES	PART NUMBER IDENTIFICATION		
UPPER PART MATERIAL	UHMWPE	Self-lubricating UHMWPE	Oil-filled PA
PART NUMBERS	See table below	Replace "MU" with "MUD" Example: 2 tracks, 90° curve angle, P/N: MUD02GAY/110	Replace "MU" with "MUD" Example: 2 tracks, 90° curve angle, P/N: MUP02GAY/110



Curve installation see page 279



Curve material see page 278

N. OF TRACKS	TOTAL WIDTH W mm	PART NUMBER					
		Curve angle $\alpha$					
		15°	30°	45°	60°	75°	90°
1	100	MU01GFY/100	MU01GEY/100	MU01GKY/100	MU01GBY/100	MU01GLY/100	MU01GAY/100
2	185	MU02GFY/110	MU02GEY/110	MU02GKY/110	MU02GBY/110	MU02GLY/110	MU02GAY/110
3	270	MU03GFY/110	MU03GEY/110	MU03GKY/110	MU03GBY/110	MU03GLY/110	MU03GAY/110
4	355	MU04GFY/110	MU04GEY/110	MU04GKY/110	MU04GBY/110	MU04GLY/110	MU04GAY/110

NOTE: For custom requests with dimensions different from the standard, please refer to page 318.

## VERSION U 06

SUITABLE FOR CHAINS:

- 793M K 4 1/2

(See page 249)

RADIUS	BASIC WIDTH	TRANSVERSAL PITCH	INFEED/OUTFEED LENGTH
mm	mm	mm	mm
500	129	120	125



Single track

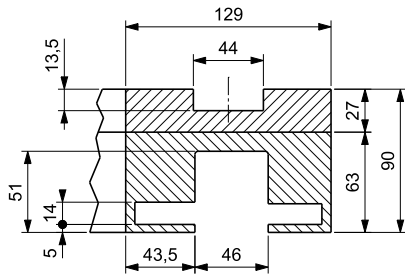

Multi track

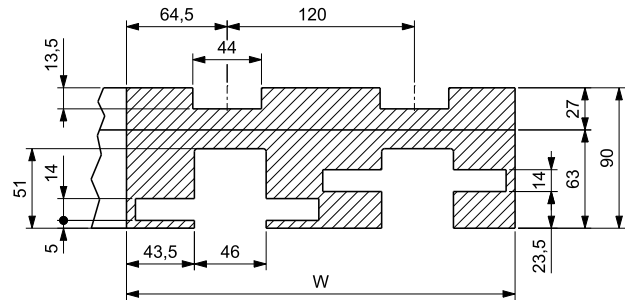

Radius

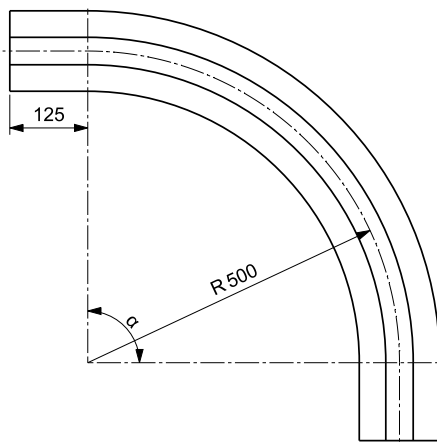

Return guide shoe

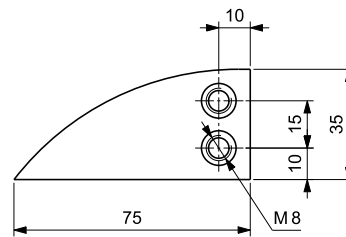

On request, Upper part is available in Self-Lubricating UHMWPE & Oil-filled PA.



CURVES	PART NUMBER IDENTIFICATION		
	SUPREME -A	SUPREME -L	SUPREME -S
UPPER PART MATERIAL	UHMWPE	Self-lubricating UHMWPE	Oil-filled PA
PART NUMBERS	See table below	Replace "MU" with "MUD" Example: 2 tracks, 90° curve angle, P/N: MUD02AAY/442	Replace "MU" with "MUP" Example: 2 tracks, 90° curve angle, P/N: MUP02AAY/442



Curve installation see page 279



Curve material see page 278

N. OF TRACKS	TOTAL WIDTH W mm	PART NUMBER					
		Curve angle α					
		15°	30°	45°	60°	75°	90°
1	129	MU01AFY/402	MU01AEY/402	MU01ACY/402	MU01ABY/402	MU01ALY/402	MU01AAY/402
2	249	MU02AFY/442	MU02AEY/442	MU02ACY/442	MU02ABY/442	MU02ALY/442	MU02AAY/442
3	369	MU03AFY/442	MU03AEY/442	MU03ACY/442	MU03ABY/442	MU03ALY/442	MU03AAY/442
4	489	MU04AFY/442	MU04AEY/442	MU04ACY/442	MU04ABY/442	MU04ALY/442	MU04AAY/442

NOTE: For custom requests with dimensions different from the standard, please refer to page 318.

On request, Magnetic curves with dimensions different from the standard can be supplied.  
Please fill the form below with the requested parameters and contact REGINA customer service.

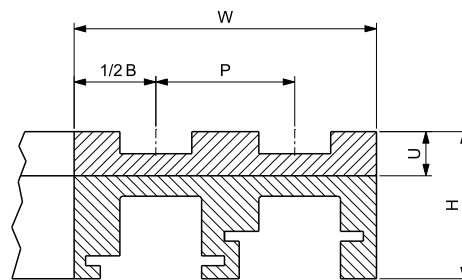
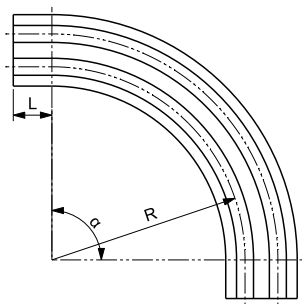

FOR CHAIN SERIES:	REQUESTED CURVE PARAMETERS		
	mm	inch	°
CHAIN WIDTH:			
FIRST RADIUS R:			
CURVE ANGLE $\alpha$ :			
N. OF TRACKS:			
TRANSVERSAL PITCH P:			
BASIC WIDTH B:			
TOTAL WIDTH W:			
INFEEED LENGTH L:			



PERFORMANCE IN MOTION

# ***FliteTop***® **Matveyor**®

TAB, Bevel and  
Low Pin Center Curves

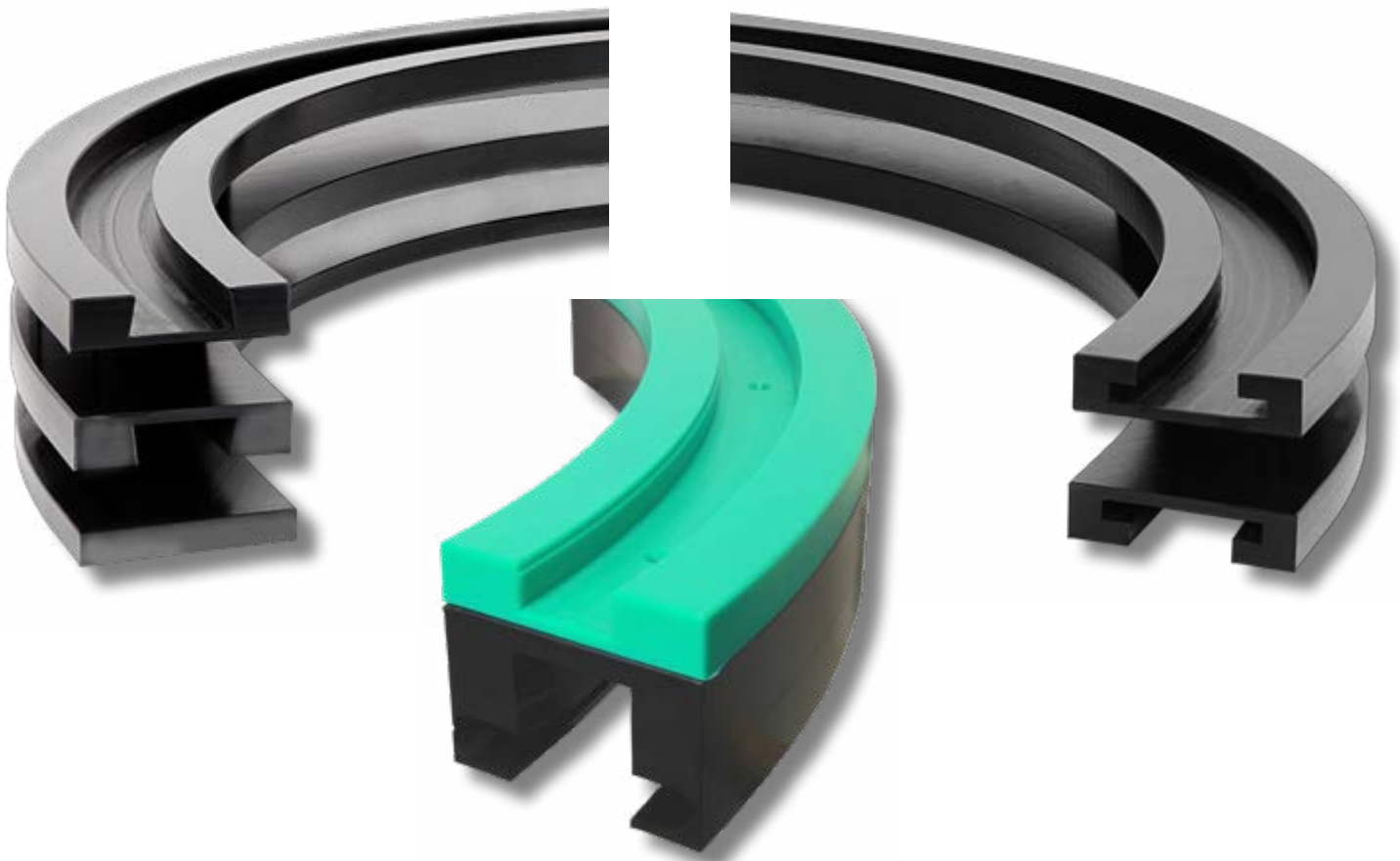



## For FliteTop® & Matveyor® SIDEFLEXING CHAINS

TAB curves include both upper and return part.

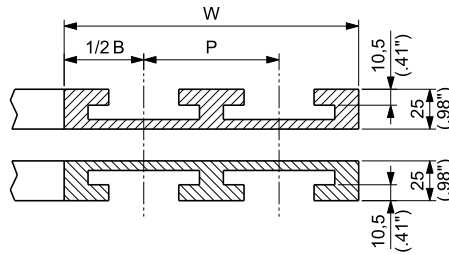
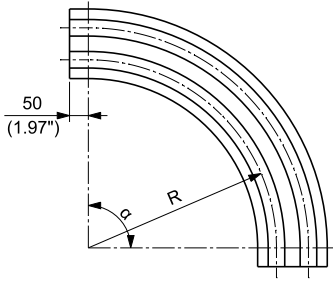

CHAIN WIDTH	TRANSVERSAL PITCH P		BASIC WIDTH B	
	mm	inch	mm	inch
3 1/4" 83,8 mm	85	3.35	100	3.94
4 1/2"	120	4.72	130	5.12
7 1/2"	195	7.68	200	7.87

On request, Upper part is available in Self-Lubricating UHMWPE & Oil-filled PA.



Curve material see page 14

CURVES	PART NUMBER IDENTIFICATION		
	UHMWPE	SUPREME -L	SUPREME -S
UPPER PART MATERIAL	UHMWPE	Self-lubricating UHMWPE	Oil-filled PA
PART NUMBERS	See table below	Replace "T80" with "T80D" Example: Radius 500 mm, 1 track, 90° curve angle for 880T chain, P/N: T80DKD1A/1000	Replace "T80" with "T80P" Example: Radius 500 mm, 1 track, 90° curve angle for 880T chain, P/N: T80PKD1A/1000

CHAIN TYPE	Series	Width	RADIUS* R		N. OF TRACKS	TOTAL WIDTH W		PART NUMBER											
			mm	inch		mm	inch	Curve angle α											
								15°	30°	45°	60°	75°	90°						
878T	982T	3 1/4"	200	7.874	1	100	3.937	T80KD1D/1F00	T80KD1D/1E00	T80KD1D/1C00	T80KD1D/1B00	T80KD1D/1L00	T80KD1D/1000						
PHDG 981T			457,2	18	1	100	3.937	T80KD10/1F00	T80KD10/1E00	T80KD10/1C00	T80KD10/1B00	T80KD10/1L00	T80KD10/1000						
					2	185	7.283	T80KD20/1F00	T80KD20/1E00	T80KD20/1C00	T80KD20/1B00	T80KD20/1L00	T80KD20/1000						
					3	270	10.630	T80KD30/1F00	T80KD30/1E00	T80KD30/1C00	T80KD30/1B00	T80KD30/1L00	T80KD30/1000						
					4	355	13.189	T80KD40/1F00	T80KD40/1E00	T80KD40/1C00	T80KD40/1B00	T80KD40/1L00	T80KD40/1000						
					5	440	15.748	T80KD50/1F00	T80KD50/1E00	T80KD50/1C00	T80KD50/1B00	T80KD50/1L00	T80KD50/1000						
880TA	880T	3 1/4"	610	24.016	1	100	3.937	T80KD1A/1F00	T80KD1A/1E00	T80KD1A/1C00	T80KD1A/1B00	T80KD1A/1L00	T80KD1A/1000						
2					185	7.283	T80KD2A/1F00	T80KD2A/1E00	T80KD2A/1C00	T80KD2A/1B00	T80KD2A/1L00	T80KD2A/1000							
3					270	10.630	T80KD3A/1F00	T80KD3A/1E00	T80KD3A/1C00	T80KD3A/1B00	T80KD3A/1L00	T80KD3A/1000							
4					355	13.189	T80KD4A/1F00	T80KD4A/1E00	T80KD4A/1C00	T80KD4A/1B00	T80KD4A/1L00	T80KD4A/1000							
5					440	15.748	T80KD5A/1F00	T80KD5A/1E00	T80KD5A/1C00	T80KD5A/1B00	T80KD5A/1L00	T80KD5A/1000							
879T	881T	83,8 mm	610	24.016	1	100	3.937	T80KD1C/1F00	T80KD1C/1E00	T80KD1C/1C00	T80KD1C/1B00	T80KD1C/1L00	T80KD1C/1000						
2					185	7.283	T80KD2C/1F00	T80KD2C/1E00	T80KD2C/1C00	T80KD2C/1B00	T80KD2C/1L00	T80KD2C/1000							
3					270	10.630	T80KD3C/1F00	T80KD3C/1E00	T80KD3C/1C00	T80KD3C/1B00	T80KD3C/1L00	T80KD3C/1000							
4					355	13.189	T80KD4C/1F00	T80KD4C/1E00	T80KD4C/1C00	T80KD4C/1B00	T80KD4C/1L00	T80KD4C/1000							
5					440	15.748	T80KD5C/1F00	T80KD5C/1E00	T80KD5C/1C00	T80KD5C/1B00	T80KD5C/1L00	T80KD5C/1000							
881T	981T		800	31.496	1	100	3.937	T80KD1T/1F00	T80KD1T/1E00	T80KD1T/1C00	T80KD1T/1B00	T80KD1T/1L00	T80KD1T/1000						
2					185	7.283	T80KD2T/1F00	T80KD2T/1E00	T80KD2T/1C00	T80KD2T/1B00	T80KD2T/1L00	T80KD2T/1000							
3					270	10.630	T80KD3T/1F00	T80KD3T/1E00	T80KD3T/1C00	T80KD3T/1B00	T80KD3T/1L00	T80KD3T/1000							
4					355	13.189	T80KD4T/1F00	T80KD4T/1E00	T80KD4T/1C00	T80KD4T/1B00	T80KD4T/1L00	T80KD4T/1000							
5					440	15.748	T80KD5T/1F00	T80KD5T/1E00	T80KD5T/1C00	T80KD5T/1B00	T80KD5T/1L00	T80KD5T/1000							
793T	783T		1000	39.370	1	100	3.937	T80KD1G/1F00	T80KD1G/1E00	T80KD1G/1C00	T80KD1G/1B00	T80KD1G/1L00	T80KD1G/1000						
2					185	7.283	T80KD2G/1F00	T80KD2G/1E00	T80KD2G/1C00	T80KD2G/1B00	T80KD2G/1L00	T80KD2G/1000							
3					270	10.630	T80KD3G/1F00	T80KD3G/1E00	T80KD3G/1C00	T80KD3G/1B00	T80KD3G/1L00	T80KD3G/1000							
4					355	13.189	T80KD4G/1F00	T80KD4G/1E00	T80KD4G/1C00	T80KD4G/1B00	T80KD4G/1L00	T80KD4G/1000							
5					440	15.748	T80KD5G/1F00	T80KD5G/1E00	T80KD5G/1C00	T80KD5G/1B00	T80KD5G/1L00	T80KD5G/1000							
981T	880T		610	24.016	1	130	5.118	T80KG1C/1F00	T80KG1C/1E00	T80KG1C/1C00	T80KG1C/1B00	T80KG1C/1L00	T80KG1C/1000						
2					250	9.843	T80KG2C/1F00	T80KG2C/1E00	T80KG2C/1C00	T80KG2C/1B00	T80KG2C/1L00	T80KG2C/1000							
879T	881T	4 1/2"	800	31.496	1	130	5.118	T80KG1T/1F00	T80KG1T/1E00	T80KG1T/1C00	T80KG1T/1B00	T80KG1T/1L00	T80KG1T/1000						
2					250	9.843	T80KG2T/1F00	T80KG2T/1E00	T80KG2T/1C00	T80KG2T/1B00	T80KG2T/1L00	T80KG2T/1000							
783T	793T		1000	39.370	1	130	5.118	T80KG1G/1F00	T80KG1G/1E00	T80KG1G/1C00	T80KG1G/1B00	T80KG1G/1L00	T80KG1G/1000						
2					250	9.843	T80KG2G/1F00	T80KG2G/1E00	T80KG2G/1C00	T80KG2G/1B00	T80KG2G/1L00	T80KG2G/1000							
881T	981T		610	24.016	1	200	7.874	T80KL1C/1F00	T80KL1C/1E00	T80KL1C/1C00	T80KL1C/1B00	T80KL1C/1L00	T80KL1C/1000						
2					395	15.551	T80KL2C/1F00	T80KL2C/1E00	T80KL2C/1C00	T80KL2C/1B00	T80KL2C/1L00	T80KL2C/1000							
PHDG 981T	PHDG 981T	7 1/2"	800	31.496	1	200	7.874	T80KL1T/1F00	T80KL1T/1E00	T80KL1T/1C00	T80KL1T/1B00	T80KL1T/1L00	T80KL1T/1000						
2					395	15.551	T80KL2T/1F00	T80KL2T/1E00	T80KL2T/1C00	T80KL2T/1B00	T80KL2T/1L00	T80KL2T/1000							
793T			1000	39.370	1	200	7.874	T80KL1G/1F00	T80KL1G/1E00	T80KL1G/1C00	T80KL1G/1B00	T80KL1G/1L00	T80KL1G/1000						
2					395	15.551	T80KL2G/1F00	T80KL2G/1E00	T80KL2G/1C00	T80KL2G/1B00	T80KL2G/1L00	T80KL2G/1000							

\* First track is intended.

NOTE: for custom requests with dimensions different from the standard, please refer to page 323.

## For FliteTop® SIDEFLEXING CHAINS

TAB curves include both upper and return part.

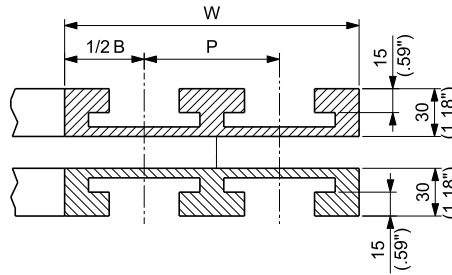
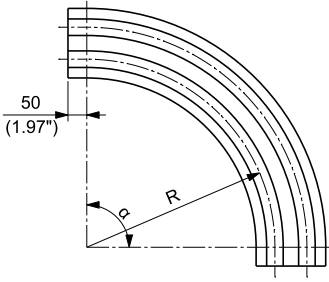

CHAIN WIDTH	TRANSVERSAL PITCH P		BASIC WIDTH B	
	mm	inch	mm	inch
3 3/4"			110	4.33
4 1/2"			130	5.12
6"	Single track		170	6.69
7 1/2"			200	7.87
10"			270	10.63
12"			320	12.60

On request, Upper part is available in Self-Lubricating UHMWPE & Oil-filled PA.



CURVES	PART NUMBER IDENTIFICATION		
	UHMWPE	SUPREME - L	SUPREME - S
UPPER PART MATERIAL	UHMWPE	Self-lubricating UHMWPE	Oil-filled PA
PART NUMBERS	See table below	Replace "T82" with "T82D" Example: Radius 700 mm, 1 track, 90° curve angle for LBP 882T K 3 3/4 chain, P/N: T82DKEA1Z/1000	Replace "T82" with "T82P" Example: Radius 700 mm, 1 track, 90° curve angle for LBP 882T K 3 3/4 chain, P/N: T82PKEA1Z/1000



Curve material see page 14

CHAIN TYPE	RADIUS R	N. OF TRACKS	TOTAL WIDTH W		PART NUMBER						
			mm	inch	Curve angle α						
Series	Width	mm	inch	mm	inch	15°	30°	45°	60°	75°	90°
LBP 882T	3 3/4"	700	27.559	110	4.331	T82KEA1Z/1F00	T82KEA1Z/1E00	T82KEA1Z/1C00	T82KEA1Z/1B00	T82KEA1Z/1L00	T82KEA1Z/1000
882T		610	24.016	130	5.118	T82KG1C/1F00	T82KG1C/1E00	T82KG1C/1C00	T82KG1C/1B00	T82KG1C/1L00	T82KG1C/1000
HFX 882T	4 1/2"	800	31.496	130	5.118	T82KG1T/1F00	T82KG1T/1E00	T82KG1T/1C00	T82KG1T/1B00	T82KG1T/1L00	T82KG1T/1000
LBP 882T		1000	39.370	130	5.118	T82KG1G/1F00	T82KG1G/1E00	T82KG1G/1C00	T82KG1G/1B00	T82KG1G/1L00	T82KG1G/1000
882T	6"	610	24.016	170	6.69	T82KH1C/1F00	T82KH1C/1E00	T82KH1C/1C00	T82KH1C/1B00	T82KH1C/1L00	T82KH1C/1000
		800	31.496	170	6.69	T82KH1T/1F00	T82KH1T/1E00	T82KH1T/1C00	T82KH1T/1B00	T82KH1T/1L00	T82KH1T/1000
		1000	39.370	170	6.69	T82KH1G/1F00	T82KH1G/1E00	T82KH1G/1C00	T82KH1G/1B00	T82KH1G/1L00	T82KH1G/1000
882T	7 1/2"	610	24.016	200	7.874	T82KL1C/1F00	T82KL1C/1E00	T82KL1C/1C00	T82KL1C/1B00	T82KL1C/1L00	T82KL1C/1000
		800	31.496	200	7.874	T82KL1T/1F00	T82KL1T/1E00	T82KL1T/1C00	T82KL1T/1B00	T82KL1T/1L00	T82KL1T/1000
		1000	39.370	200	7.874	T82KL1G/1F00	T82KL1G/1E00	T82KL1G/1C00	T82KL1G/1B00	T82KL1G/1L00	T82KL1G/1000
882T	10"	610	24.016	270	10.630	T82KM1C/1F00	T82KM1C/1E00	T82KM1C/1C00	T82KM1C/1B00	T82KM1C/1L00	T82KM1C/1000
		800	31.496	270	10.630	T82KM1T/1F00	T82KM1T/1E00	T82KM1T/1C00	T82KM1T/1B00	T82KM1T/1L00	T82KM1T/1000
		1000	39.370	270	10.630	T82KM1G/1F00	T82KM1G/1E00	T82KM1G/1C00	T82KM1G/1B00	T82KM1G/1L00	T82KM1G/1000
882T	12"	610	24.016	320	12.598	T82KN1C/1F00	T82KN1C/1E00	T82KN1C/1C00	T82KN1C/1B00	T82KN1C/1L00	T82KN1C/1000
		800	31.496	320	12.598	T82KN1T/1F00	T82KN1T/1E00	T82KN1T/1C00	T82KN1T/1B00	T82KN1T/1L00	T82KN1T/1000
		1000	39.370	320	12.598	T82KN1G/1F00	T82KN1G/1E00	T82KN1G/1C00	T82KN1G/1B00	T82KN1G/1L00	T82KN1G/1000

NOTE: for custom requests with dimensions different from the standard, please refer to page 323.

## For FliteTop® SIDEFLEXING CHAINS

TAB curves include both upper and return part.

### FOR 1843T CHAIN

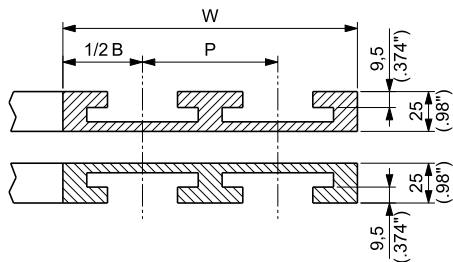

### FOR 1701T CHAIN

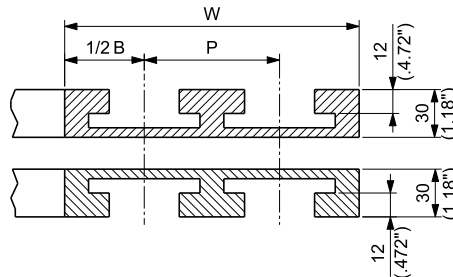

### FOR ALL OTHER CHAINS

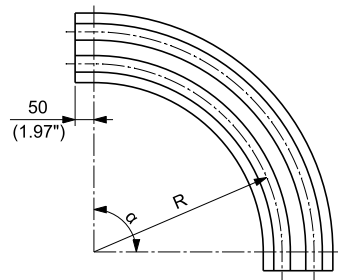
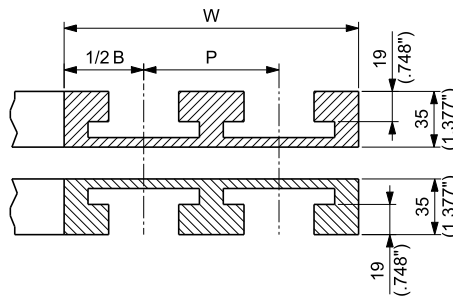

CHAIN WIDTH	TRANSVERSAL PITCH P		BASIC WIDTH B	
	mm	inch	mm	inch
1 1/4"			50	1.97
53mm			100	3.94
2 1/4"			75	2.95
3 1/4"			100	3.94
4 1/2"	Single track		130	5.12
6"			170	6.69
7 1/2"			200	7.87
10"			270	10.63
12"			320	12.60
16"			420	16.54

On request, Upper part is available in Self-Lubricating UHMWPE & Oil-filled PA.



Curve material see page 14

### PART NUMBER IDENTIFICATION

CURVES	UHMWPE	SUPREME -L	SUPREME -S
UPPER PART MATERIAL	UHMWPE	Self-lubricating UHMWPE	Oil-filled PA
PART NUMBERS	See table below	Replace "T73" with "T73D" Replace "T43" with "T43D" Replace "T17" with "T17D" Example: Radius 500 mm, 1 track, 90° curve angle for 1863T K 2 1/4" chain, P/N: T73DKS1A/1000	Replace "T73" with "T73P" Replace "T43" with "T43P" Replace "T17" with "T17P" Example: Radius 500 mm, 1 track, 90° curve angle for 1863T K 2 1/4" chain, P/N: T73PKS1A/1000

CHAIN TYPE	RADIUS R	N. OF TRACKS	TOTAL WIDTH W		PART NUMBER							
			mm	inch	Curve angle α							
Series	Width	mm	inch	mm	inch	15°	30°	45°	60°	75°	90°	
1863T	2 1/4"	500	19.685	1	75	2.95	T73KS1A/1F00	T73KS1A/1E00	T73KS1A/1C00	T73KS1A/1B00	T73KS1A/1L00	T73KS1A/1000
1874T	3 1/4"	500	19.685	1	100	3.94	T73KD1A/1F00	T73KD1A/1E00	T73KD1A/1C00	T73KD1A/1B00	T73KD1A/1L00	T73KD1A/1000
1863T		610	24.016	1	100	3.94	T73KD1C/1F00	T73KD1C/1E00	T73KD1C/1C00	T73KD1C/1B00	T73KD1C/1L00	T73KD1C/1000
1873T		800	31.496	1	100	3.94	T73KD1T/1F00	T73KD1T/1E00	T73KD1T/1C00	T73KD1T/1B00	T73KD1T/1L00	T73KD1T/1000
HFX 1873T	4 1/2"	1000	39.370	1	100	3.94	T73KD1G/1F00	T73KD1G/1E00	T73KD1G/1C00	T73KD1G/1B00	T73KD1G/1L00	T73KD1G/1000
1874T		610	24.016	1	130	5.12	T73KG1C/1F00	T73KG1C/1E00	T73KG1C/1C00	T73KG1C/1B00	T73KG1C/1L00	T73KG1C/1000
1863T		800	31.496	1	130	5.12	T73KG1T/1F00	T73KG1T/1E00	T73KG1T/1C00	T73KG1T/1B00	T73KG1T/1L00	T73KG1T/1000
1873T	1000	39.370	1	130	5.12	T73KG1G/1F00	T73KG1G/1E00	T73KG1G/1C00	T73KG1G/1B00	T73KG1G/1L00	T73KG1G/1000	
HFX 1873T	6"	500	19.685	1	170	6.69	T73KH1A/1F00	T73KH1A/1E00	T73KH1A/1C00	T73KH1A/1B00	T73KH1A/1L00	T73KH1A/1000
1874T		610	24.016	1	200	7.87	T73KL1C/1F00	T73KL1C/1E00	T73KL1C/1C00	T73KL1C/1B00	T73KL1C/1L00	T73KL1C/1000
1863T		800	31.496	1	200	7.87	T73KL1T/1F00	T73KL1T/1E00	T73KL1T/1C00	T73KL1T/1B00	T73KL1T/1L00	T73KL1T/1000
1873T	1000	39.370	1	200	7.87	T73KL1G/1F00	T73KL1G/1E00	T73KL1G/1C00	T73KL1G/1B00	T73KL1G/1L00	T73KL1G/1000	
HFX 1873T	7 1/2"	610	24.016	1	270	10.63	T73KM1C/1F00	T73KM1C/1E00	T73KM1C/1C00	T73KM1C/1B00	T73KM1C/1L00	T73KM1C/1000
1874T		800	31.496	1	270	10.63	T73KM1T/1F00	T73KM1T/1E00	T73KM1T/1C00	T73KM1T/1B00	T73KM1T/1L00	T73KM1T/1000
1873T		1000	39.370	1	270	10.63	T73KM1G/1F00	T73KM1G/1E00	T73KM1G/1C00	T73KM1G/1B00	T73KM1G/1L00	T73KM1G/1000
HFX 1873T	10"	610	24.016	1	320	12.60	T73KN1C/1F00	T73KN1C/1E00	T73KN1C/1C00	T73KN1C/1B00	T73KN1C/1L00	T73KN1C/1000
1863T		800	31.496	1	320	12.60	T73KN1T/1F00	T73KN1T/1E00	T73KN1T/1C00	T73KN1T/1B00	T73KN1T/1L00	T73KN1T/1000
1873T		1000	39.370	1	320	12.60	T73KN1G/1F00	T73KN1G/1E00	T73KN1G/1C00	T73KN1G/1B00	T73KN1G/1L00	T73KN1G/1000
HFX 1873T	12"	800	31.496	1	420	16.54	T73KJ1T/1F00	T73KJ1T/1E00	T73KJ1T/1C00	T73KJ1T/1B00	T73KJ1T/1L00	T73KJ1T/1000
1863T		1000	39.370	1	420	16.54	T73KJ1G/1F00	T73KJ1G/1E00	T73KJ1G/1C00	T73KJ1G/1B00	T73KJ1G/1L00	T73KJ1G/1000
1873T		300	11.811	1	50	1.97	T43KPA1Y/1F00	T43KPA1Y/1E00	T43KPA1Y/1C00	T43KPA1Y/1B00	T43KPA1Y/1L00	T43KPA1Y/1000
HFX 1873T	1 1/4"	500	19.685	1	50	1.97	T43KPA1A/1F00	T43KPA1A/1E00	T43KPA1A/1C00	T43KPA1A/1B00	T43KPA1A/1L00	T43KPA1A/1000
1843T		300	11.811	1	50	1.97	T43KPA1Y/1F00	T43KPA1Y/1E00	T43KPA1Y/1C00	T43KPA1Y/1B00	T43KPA1Y/1L00	T43KPA1Y/1000
1701T		53mm	250	9.843	1	100	3.94	T17KD1V/1F00	T17KD1V/1E00	T17KD1V/1C00	T17KD1V/1B00	T17KD1V/1L00
		500	19.685	1	100	3.94	T17KD1A/1F00	T17KD1A/1E00	T17KD1A/1C00	T17KD1A/1B00	T17KD1A/1L00	T17KD1A/1000

NOTE: for custom requests with dimensions different from the standard, please refer to page 323.

On request, TAB curves with dimensions different from the standard can be supplied.  
Please fill the form below with the requested parameters and contact REGINA customer service.

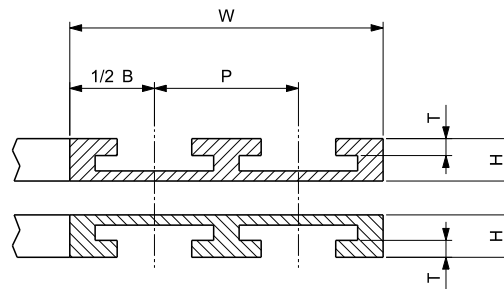
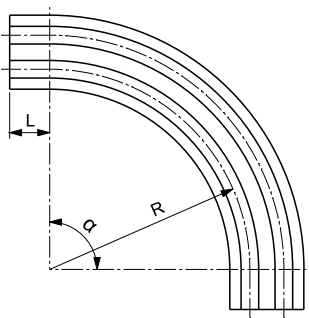



FOR CHAIN SERIES:	REQUESTED CURVE PARAMETERS		
	mm	inch	°
CHAIN WIDTH:			
FIRST RADIUS R:			
CURVE ANGLE $\alpha$ :			
N. OF TRACKS:			
TRANSVERSAL PITCH P:			
BASIC WIDTH B:			
TOTAL WIDTH W:			
INFEED LENGTH L:			

## For Matveyor® SIDEFLEXING BELTS

TAB curves for sideflexing belts include upper part only.

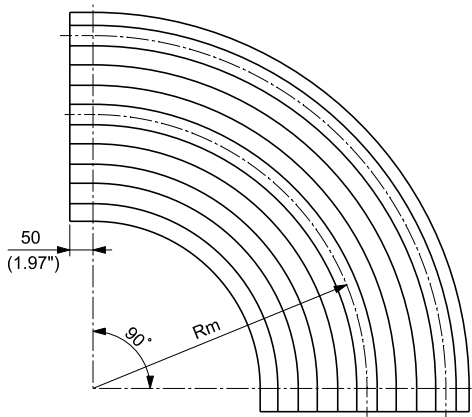
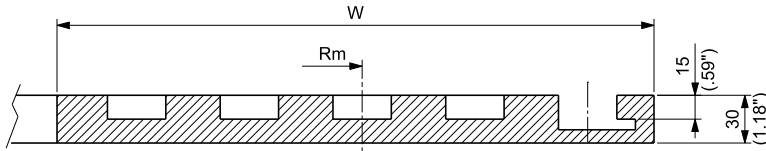
For more information on how to support the sideflexing belts in the return part, please contact REGINA application engineers.



The curves are manufactured in  material



Curve material  
see page 14

BELT TYPE	BELT WIDTH		MEDIUM RADIUS Rm		CURVE WIDTH W		PART NUMBER	
	mm	inch	mm	inch	mm	inch		
2556HTB	Series							
		255	10.039	600	23.622	281	11.063	<b>T55HK0281/B10</b>
		340	13.386	800	31.496	366	14.409	<b>T55HK0366/C10</b>
		425	16.732	1000	39.370	451	17.756	<b>T55HK0451/D10</b>
		510	20.079	1200	47.224	536	21.102	<b>T55HK0536/E10</b>
		595	23.425	1400	55.118	621	24.449	<b>T55HK0621/F10</b>
		680	26.772	1600	62.992	706	27.795	<b>T55HK0706/G10</b>
		765	30.118	1800	70.866	791	31.142	<b>T55HK0791/H10</b>
2556HTB-SR		850	33.465	2000	78.740	876	34.488	<b>T55HK0876/J10</b>
		340	13.386	500	19.685	366	14.409	<b>T55HK0366/A10</b>
		425	16.732	600	23.622	451	17.756	<b>T55HK0451/B10</b>
		510	20.079	800	31.496	536	21.102	<b>T55HK0536/C10</b>
		595	23.425	1000	39.370	621	24.449	<b>T55HK0621/D10</b>
		680	26.772	1200	47.224	706	27.795	<b>T55HK0706/E10</b>
		765	30.118	1400	55.118	791	31.142	<b>T55HK0791/F10</b>
		850	33.465	1600	62.992	876	34.488	<b>T55HK0876/G10</b>

## For FliteTop® SIDEFLEXING CHAINS

Bevel curves include 3 parts: upper, return and support plate.

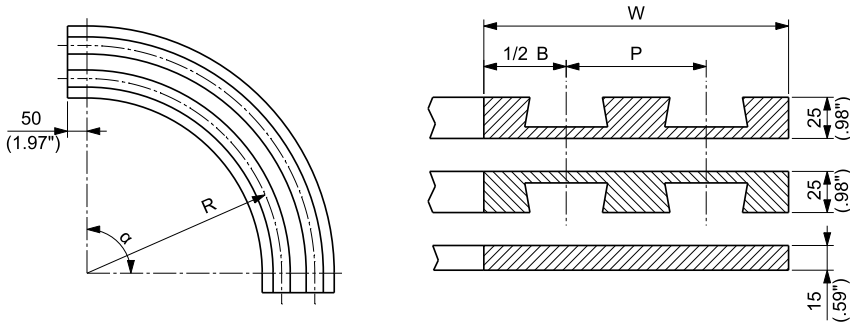

CHAIN WIDTH	TRANSVERSAL PITCH P		BASIC WIDTH B	
	mm	inch	mm	inch
3 1/4" 83,8 mm	85	3.35	100	3.94
4 1/2"	120	4.72	130	5.12
7 1/2"	195	7.68	200	7.87

On request, Upper part is available in Self-Lubricating UHMWPE & Oil-filled PA.



Curve material see page 14

CURVES	PART NUMBER IDENTIFICATION		
	UHMWPE	SUPREME-L	SUPREME-S
UPPER PART MATERIAL	UHMWPE	Self-lubricating UHMWPE	Oil-filled PA
PART NUMBERS	See table below	Replace "B80" with "B80D" Example: Radius 500 mm, 1 track, 90° curve angle for 880 K 3 1/4 chain, P/N: B80DK1A/1000	Replace "B80" with "B80P" Example: Radius 500 mm, 1 track, 90° curve angle for 880 K 3 1/4 chain, P/N: B80PK1A/1000

CHAIN TYPE	RADIUS* R	N. OF TRACKS	TOTAL WIDTH W		PART NUMBER								
			mm	inch	Curve angle α								
Series	Width		mm	inch	15°	30°	45°	60°	75°	90°			
880 879 881 981	3 1/4" 83.8 mm	18	457,2	18	1	100	3.937	B80KD10/1F00	B80KD10/1E00	B80KD10/1C00	B80KD10/1B00	B80KD10/1L00	B80KD10/1000
					2	185	7.283	B80KD20/1F00	B80KD20/1E00	B80KD20/1C00	B80KD20/1B00	B80KD20/1L00	B80KD20/1000
					3	270	10.630	B80KD30/1F00	B80KD30/1E00	B80KD30/1C00	B80KD30/1B00	B80KD30/1L00	B80KD30/1000
					4	355	13.189	B80KD40/1F00	B80KD40/1E00	B80KD40/1C00	B80KD40/1B00	B80KD40/1L00	B80KD40/1000
					5	440	15.748	B80KD50/1F00	B80KD50/1E00	B80KD50/1C00	B80KD50/1B00	B80KD50/1L00	B80KD50/1000
	500	19.685			1	100	3.937	B80KD1A/1F00	B80KD1A/1E00	B80KD1A/1C00	B80KD1A/1B00	B80KD1A/1L00	B80KD1A/1000
					2	185	7.283	B80KD2A/1F00	B80KD2A/1E00	B80KD2A/1C00	B80KD2A/1B00	B80KD2A/1L00	B80KD2A/1000
					3	270	10.630	B80KD3A/1F00	B80KD3A/1E00	B80KD3A/1C00	B80KD3A/1B00	B80KD3A/1L00	B80KD3A/1000
					4	355	13.189	B80KD4A/1F00	B80KD4A/1E00	B80KD4A/1C00	B80KD4A/1B00	B80KD4A/1L00	B80KD4A/1000
					5	440	15.748	B80KD5A/1F00	B80KD5A/1E00	B80KD5A/1C00	B80KD5A/1B00	B80KD5A/1L00	B80KD5A/1000
	610	24.016			1	100	3.937	B80KD1C/1F00	B80KD1C/1E00	B80KD1C/1C00	B80KD1C/1B00	B80KD1C/1L00	B80KD1C/1000
					2	185	7.283	B80KD2C/1F00	B80KD2C/1E00	B80KD2C/1C00	B80KD2C/1B00	B80KD2C/1L00	B80KD2C/1000
					3	270	10.630	B80KD3C/1F00	B80KD3C/1E00	B80KD3C/1C00	B80KD3C/1B00	B80KD3C/1L00	B80KD3C/1000
					4	355	13.189	B80KD4C/1F00	B80KD4C/1E00	B80KD4C/1C00	B80KD4C/1B00	B80KD4C/1L00	B80KD4C/1000
					5	440	15.748	B80KD5C/1F00	B80KD5C/1E00	B80KD5C/1C00	B80KD5C/1B00	B80KD5C/1L00	B80KD5C/1000
800	31.496			1	100	3.937	B80KD1T/1F00	B80KD1T/1E00	B80KD1T/1C00	B80KD1T/1B00	B80KD1T/1L00	B80KD1T/1000	
				2	185	7.283	B80KD2T/1F00	B80KD2T/1E00	B80KD2T/1C00	B80KD2T/1B00	B80KD2T/1L00	B80KD2T/1000	
				3	270	10.630	B80KD3T/1F00	B80KD3T/1E00	B80KD3T/1C00	B80KD3T/1B00	B80KD3T/1L00	B80KD3T/1000	
				4	355	13.189	B80KD4T/1F00	B80KD4T/1E00	B80KD4T/1C00	B80KD4T/1B00	B80KD4T/1L00	B80KD4T/1000	
				5	440	15.748	B80KD5T/1F00	B80KD5T/1E00	B80KD5T/1C00	B80KD5T/1B00	B80KD5T/1L00	B80KD5T/1000	
				6	525	20.669	B80KD6T/1F00	B80KD6T/1E00	B80KD6T/1C00	B80KD6T/1B00	B80KD6T/1L00	B80KD6T/1000	
1000	39.370			1	100	3.937	B80KD1G/1F00	B80KD1G/1E00	B80KD1G/1C00	B80KD1G/1B00	B80KD1G/1L00	B80KD1G/1000	
				2	185	7.283	B80KD2G/1F00	B80KD2G/1E00	B80KD2G/1C00	B80KD2G/1B00	B80KD2G/1L00	B80KD2G/1000	
				3	270	10.630	B80KD3G/1F00	B80KD3G/1E00	B80KD3G/1C00	B80KD3G/1B00	B80KD3G/1L00	B80KD3G/1000	
				4	355	13.189	B80KD4G/1F00	B80KD4G/1E00	B80KD4G/1C00	B80KD4G/1B00	B80KD4G/1L00	B80KD4G/1000	
				5	440	15.748	B80KD5G/1F00	B80KD5G/1E00	B80KD5G/1C00	B80KD5G/1B00	B80KD5G/1L00	B80KD5G/1000	
880 879 881 981	4 1/2"			1	130	5.118	B80KG1C/1F00	B80KG1C/1E00	B80KG1C/1C00	B80KG1C/1B00	B80KG1C/1L00	B80KG1C/1000	
				2	250	9.843	B80KG2C/1F00	B80KG2C/1E00	B80KG2C/1C00	B80KG2C/1B00	B80KG2C/1L00	B80KG2C/1000	
				1	130	5.118	B80KG1T/1F00	B80KG1T/1E00	B80KG1T/1C00	B80KG1T/1B00	B80KG1T/1L00	B80KG1T/1000	
				2	250	9.843	B80KG2T/1F00	B80KG2T/1E00	B80KG2T/1C00	B80KG2T/1B00	B80KG2T/1L00	B80KG2T/1000	
881 981	7 1/2"			1	130	5.118	B80KG1G/1F00	B80KG1G/1E00	B80KG1G/1C00	B80KG1G/1B00	B80KG1G/1L00	B80KG1G/1000	
				2	250	9.843	B80KG2G/1F00	B80KG2G/1E00	B80KG2G/1C00	B80KG2G/1B00	B80KG2G/1L00	B80KG2G/1000	
881 981	7 1/2"			610	1	200	7.874	B80KL1C/1F00	B80KL1C/1E00	B80KL1C/1C00	B80KL1C/1B00	B80KL1C/1L00	B80KL1C/1000
					2	395	15.551	B80KL2C/1F00	B80KL2C/1E00	B80KL2C/1C00	B80KL2C/1B00	B80KL2C/1L00	B80KL2C/1000
				800	1	200	7.874	B80KL1T/1F00	B80KL1T/1E00	B80KL1T/1C00	B80KL1T/1B00	B80KL1T/1L00	B80KL1T/1000
					2	395	15.551	B80KL2T/1F00	B80KL2T/1E00	B80KL2T/1C00	B80KL2T/1B00	B80KL2T/1L00	B80KL2T/1000
				1000	1	200	7.874	B80KL1G/1F00	B80KL1G/1E00	B80KL1G/1C00	B80KL1G/1B00	B80KL1G/1L00	B80KL1G/1000
					2	395	15.551	B80KL2G/1F00	B80KL2G/1E00	B80KL2G/1C00	B80KL2G/1B00	B80KL2G/1L00	B80KL2G/1000

\* First track is intended.

NOTE: for custom requests with dimensions different from the standard, please refer to page 327.



## For FliteTop® SIDEFLEXING CHAINS

Bevel curves include 3 parts: upper, return and support plate.

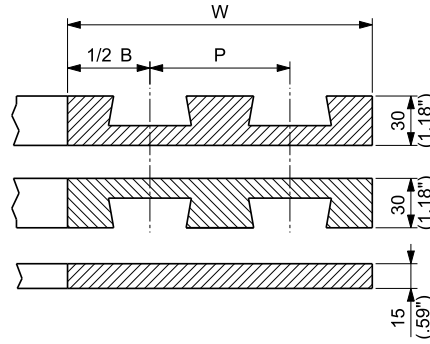
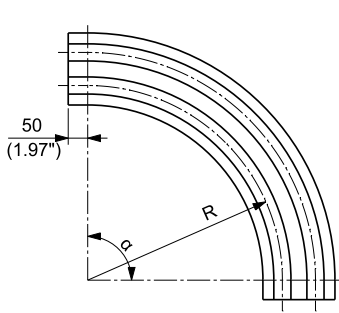

CHAIN WIDTH	TRANSVERSAL PITCH P		BASIC WIDTH B	
	mm	inch	mm	inch
4 1/2"			130	5.12
7 1/2"		Single track	200	7.87
10"			270	10.63
12"			320	12.60

On request, Upper part is available in Self-Lubricating UHMWPE & Oil-filled PA.



CURVES	PART NUMBER IDENTIFICATION		
	UHMWPE	SUPREME -L	SUPREME -S
UPPER PART MATERIAL	UHMWPE	Self-lubricating UHMWPE	Oil-filled PA
PART NUMBERS	See table below	Replace "B82" with "B82D" Example: Radius 610 mm, 1 tracks, 90° curve angle for 882 K 4 1/2 chain, P/N: B82DKG1C/1000	Replace "B82" with "B82P" Example: Radius 610 mm, 1 tracks, 90° curve angle for 882 K 4 1/2 chain, P/N: B82PKG1C/1000

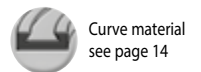

CHAIN TYPE		RADIUS R		N. OF TRACKS	TOTAL WIDTH W		PART NUMBER						
Series	Width	mm	inch		mm	inch	Curve angle alpha						
						15°	30°	45°	60°	75°	90°		
882	4 1/2"	610	24.016	1	130	5.118	B82KG1C/1F00	B82KG1C/1E00	B82KG1C/1C00	B82KG1C/1B00	B82KG1C/1L00	B82KG1C/1000	
		800	31.496	1	130	5.118	B82KL1T/1F00	B82KL1T/1E00	B82KL1T/1C00	B82KL1T/1B00	B82KL1T/1L00	B82KL1T/1000	
		1000	39.370	1	130	5.118	B82KM1G/1F00	B82KM1G/1E00	B82KM1G/1C00	B82KM1G/1B00	B82KM1G/1L00	B82KM1G/1000	
	7 1/2"	610	24.016	1	200	7.874	B82KL1C/1F00	B82KL1C/1E00	B82KL1C/1C00	B82KL1C/1B00	B82KL1C/1L00	B82KL1C/1000	
		800	31.496	1	200	7.874	B82KL1T/1F00	B82KL1T/1E00	B82KL1T/1C00	B82KL1T/1B00	B82KL1T/1L00	B82KL1T/1000	
		1000	39.370	1	200	7.874	B82KL1G/1F00	B82KL1G/1E00	B82KL1G/1C00	B82KL1G/1B00	B82KL1G/1L00	B82KL1G/1000	
	10"	610	24.016	1	270	10.630	B82KM1C/1F00	B82KM1C/1E00	B82KM1C/1C00	B82KM1C/1B00	B82KM1C/1L00	B82KM1C/1000	
		800	31.496	1	270	10.630	B82KM1T/1F00	B82KM1T/1E00	B82KM1T/1C00	B82KM1T/1B00	B82KM1T/1L00	B82KM1T/1000	
		1000	39.370	1	270	10.630	B82KM1G/1F00	B82KM1G/1E00	B82KM1G/1C00	B82KM1G/1B00	B82KM1G/1L00	B82KM1G/1000	
	12"	610	24.016	1	320	12.598	B82KN1C/1F00	B82KN1C/1E00	B82KN1C/1C00	B82KN1C/1B00	B82KN1C/1L00	B82KN1C/1000	
		800	31.496	1	320	12.598	B82KN1T/1F00	B82KN1T/1E00	B82KN1T/1C00	B82KN1T/1B00	B82KN1T/1L00	B82KN1T/1000	
		1000	39.370	1	320	12.598	B82KN1G/1F00	B82KN1G/1E00	B82KN1G/1C00	B82KN1G/1B00	B82KN1G/1L00	B82KN1G/1000	

NOTE: for custom requests with dimensions different from the standard, please refer to page 327.

On request, TAB curves with dimensions different from the standard can be supplied.  
Please fill the form below with the requested parameters and contact REGINA customer service.

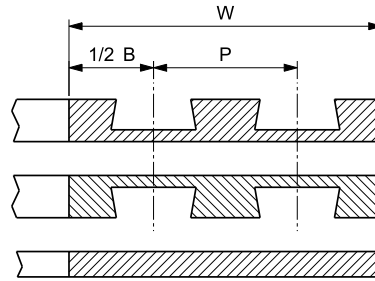
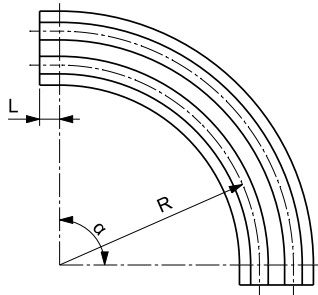

FOR CHAIN SERIES:	REQUESTED CURVE PARAMETERS		
	mm	inch	°
CHAIN WIDTH:			
FIRST RADIUS R:			
CURVE ANGLE $\alpha$ :			
N. OF TRACKS:			
TRANSVERSAL PITCH P:			
BASIC WIDTH B:			
TOTAL WIDTH W:			
INFEED LENGTH L:			

## For Matveyor® SIDEFLEXING CHAINS

Low Pin Center curves include both upper and return parts.

CHAIN WIDTH	TRANSVERSAL PITCH P		BASIC WIDTH B		INFEED/OUTFEED LENGHT	
	mm	inch	mm	inch	mm	inch
4 1/2"	116	4.57	125	5.92	-	-



Single track

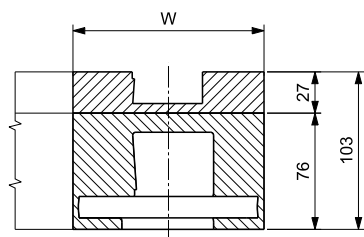

Multi track

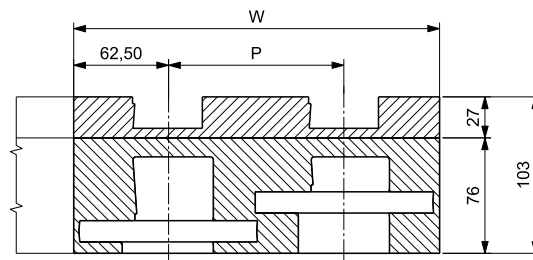

Radius

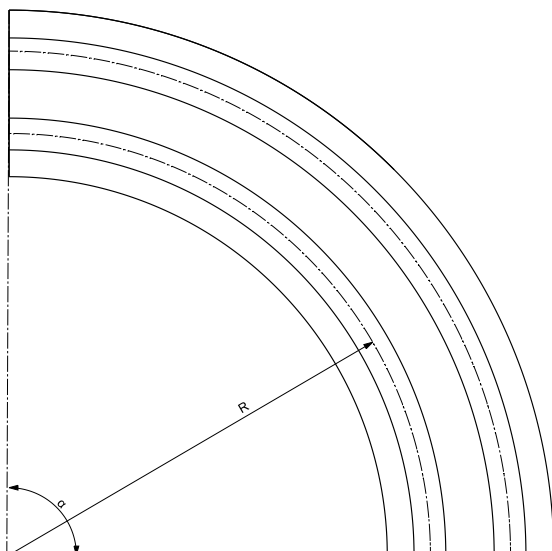

On request, Upper part is available in Self-Lubricating UHMWPE & Oil-filled PA.



Curve material see page 14

### PART NUMBER IDENTIFICATION

CURVES	SUPREME -A	SUPREME -L	SUPREME -S
UPPER PART MATERIAL	UHMWPE	Self-lubricating UHMWPE	Oil-filled PA
PART NUMBERS	See table below	Replace "L93" with "L93D"	Replace "L93" with "L93P"
		Example: Radius 610 mm, 1 track, 90° curve angle, P/N: L93DKGC1C/0000	Example: Radius 610 mm, 1 track, 90° curve angle, P/N: L93PKGC1C/0000

CHAIN TYPE	RADIUS* R	N. OF TRACKS	TOTAL WIDTH W		PART NUMBER							
			mm	inch	Curve angle α							
793L	4 1/2"	610	24.02	1	125	4.92	L93KGC1C/0F00	L93KGC1C/0E00	L93KGC1C/0C00	L93KGC1C/0B00	L93KGC1C/0L00	L93KGC1C/0000
				2	241	9.49	L93KGC2C/0F80	L93KGC2C/0E80	L93KGC2C/0C80	L93KGC2C/0B80	L93KGC2C/0L80	L93KGC2C/0080
				3	357	14.06	L93KGC3C/0F80	L93KGC3C/0E80	L93KGC3C/0C80	L93KGC3C/0B80	L93KGC3C/0L80	L93KGC3C/0080
				4	473	18.62	L93KGC4C/0F80	L93KGC4C/0E80	L93KGC4C/0C80	L93KGC4C/0B80	L93KGC4C/0L80	L93KGC4C/0080
				5	589	23.19	L93KGC5C/0F80	L93KGC5C/0E80	L93KGC5C/0C80	L93KGC5C/0B80	L93KGC5C/0L80	L93KGC5C/0080

\* First track is intended.

NOTE: for custom requests with dimensions different from the standard, please refer to page 329.

On request, Low Pin Center curves with dimensions different from the standard can be supplied. Please fill the form below with the requested parameters and contact REGINA customer service.

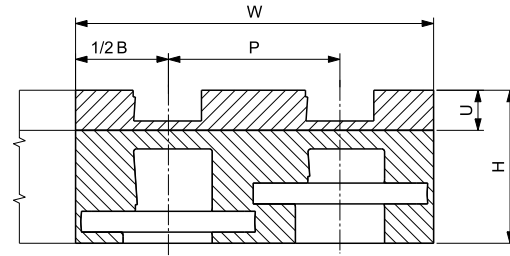
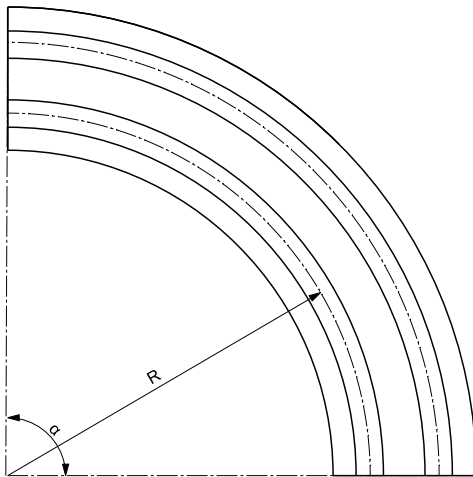
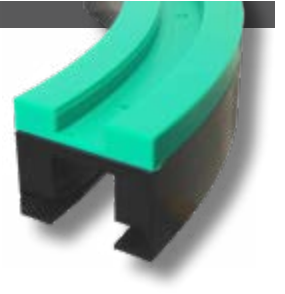

FOR CHAIN SERIES:	REQUESTED CURVE PARAMETERS		
	mm	inch	°
CHAIN WIDTH:			
FIRST RADIUS R:			
CURVE ANGLE $\alpha$ :			
N. OF TRACKS:			
TRANSVERSAL PITCH P:			
BASIC WIDTH B:			
TOTAL WIDTH W:			
INFEEED LENGTH L:			



PERFORMANCE IN MOTION

# *FliteTop*<sup>®</sup> Matveyor<sup>®</sup> ULTOP<sup>®</sup>

## Conveyor Components

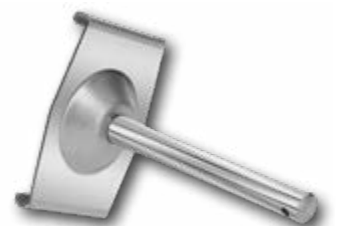

Modular transfer plates with rollers create a smooth transfer head between two conveyors. They are available in 85 mm and 115 mm width and they can be used individually or back to back.



## MATERIALS

PLATE AND ROLLERS: **UP** ULTRA PERFORMANCE HOMOPOLYMER DELRIN®

SCREWS\*: **SS** STAINLESS STEEL

\*Screws are included in the transfer plate.

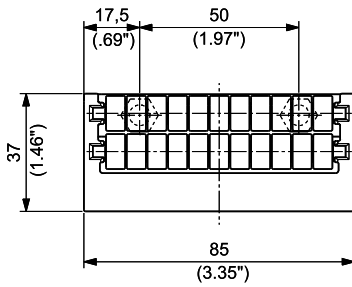
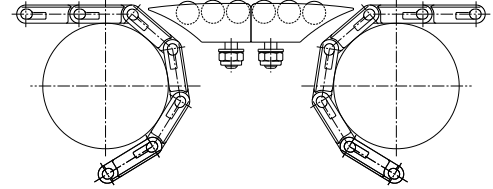

PART NUMBER **LTP-2RKQ**

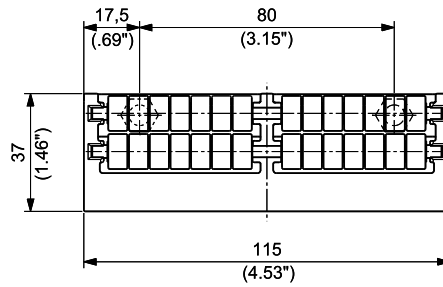

PART NUMBER **LTP-2RKG**

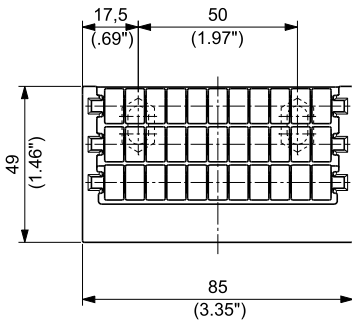
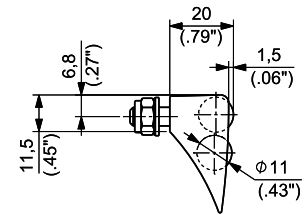

PART NUMBER **LTP-3RKQ**

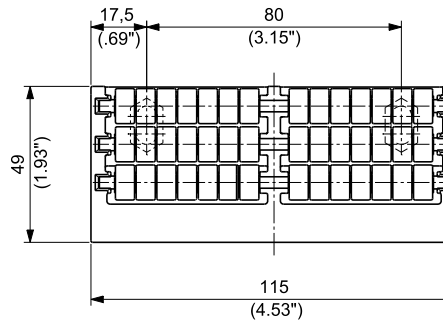

PART NUMBER **LTP-3RKG**

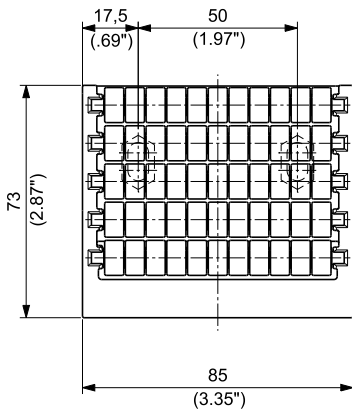
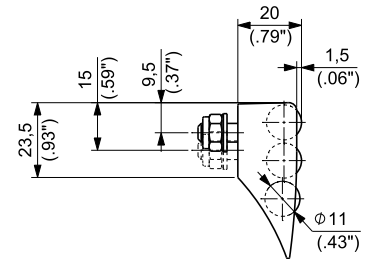

PART NUMBER **LTP-5RKQ**

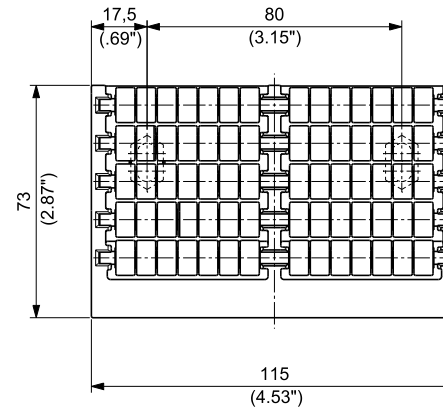

PART NUMBER **LTP-5RKG**

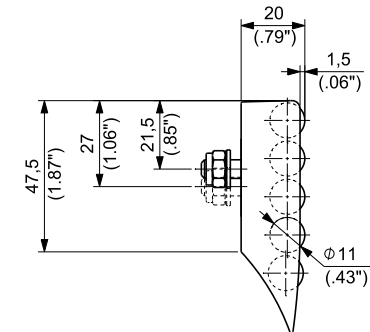

Standard packaging:  
10 pieces



## RETURN ROLLERS

Completely closed design for high hygiene standard, suitable also for food applications.  
Extremely lightweight design and optimum rotation capability.  
No absorption of liquids and lubricants combined with high chemical resistance.

**NEW**



### MATERIALS

ROLLERS: **HDPE** HD POLYETHYLENE

STANDARD ROLLER

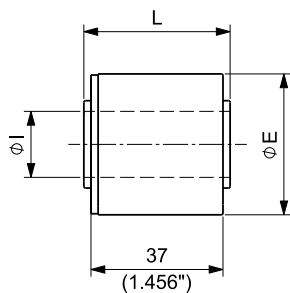

FLANGED ROLLER

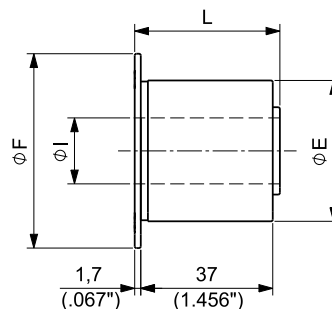

DOUBLE ROLLER

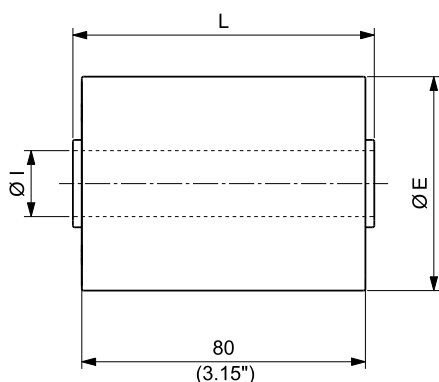

FLANGED DOUBLE ROLLER

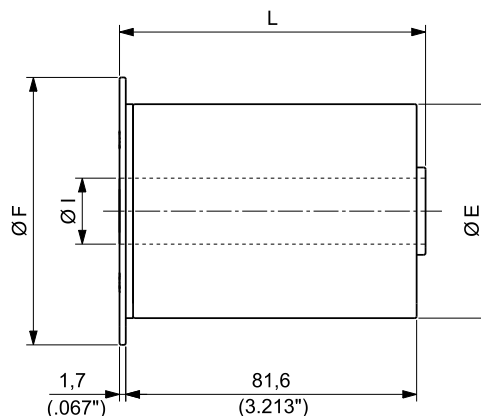

VERSION	EXTERNAL DIAMETER Ø E		LENGTH L		FLANGE DIAMETER Ø F		PART NUMBER FOR SHAFT DIAMETER Ø I			
	mm	inch	mm	inch	mm	inch	16 mm	18 mm	¾"	20 mm
STANDARD ROLLER	40	1.575	41,0	1.614	-	-	CC000424	CC000427	CC000430	CC000433
	50	1.969	41,0	1.614	-	-	CC000425	CC000428	CC000431	CC000434
	60	2.362	41,0	1.614	-	-	CC000426	CC000429	CC000432	CC000435
DOUBLE ROLLER	40	1.575	82,5	3.248	-	-	CC000054	CC000060	CC000066	CC000072
			84,5	3.327	-	-	CC000055	CC000061	CC000067	CC000073
	50	1.969	82,5	3.248	-	-	CC000056	CC000062	CC000068	CC000074
			84,5	3.327	-	-	CC000057	CC000063	CC000069	CC000075
	60	2.362	82,5	3.248	-	-	CC000058	CC000064	CC000070	CC000076
			84,5	3.327	-	-	CC000059	CC000065	CC000071	CC000077
FLANGED ROLLER	40	1.575	41,0	1.614	55	2.165	CC000448	CC000451	CC000454	CC000457
	50	1.969	41,0	1.614	65	2.559	CC000449	CC000452	CC000455	CC000458
	60	2.362	41,0	1.614	75	2.953	CC000450	CC000453	CC000456	CC000459
FLANGED DOUBLE ROLLERS	40	1.575	85,8	3.378	55	2.165	CC000102	CC000105	CC000108	CC000111
	50	1.969	85,8	3.378	65	2.559	CC000103	CC000106	CC000109	CC000112
	60	2.362	85,8	3.378	75	2.953	CC000104	CC000107	CC000110	CC000113



Standard packaging:  
50 pieces

**NEW**



## RUBBERIZED RETURN ROLLERS

Completely closed design for high hygiene standard, suitable also for food applications. The external rubber layer guarantees high grip with the chain (superior roller rotation capability), minimum chain wear and reduced noise level.

### MATERIALS

ROLLERS: **HDPE** HD POLYETHYLENE  
 RUBBER: **TPE** THERMOPLASTIC  
 Hardness: 65 ShA

STANDARD RUBBERIZED ROLLER

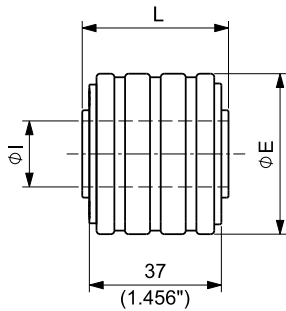

FLANGED RUBBERIZED ROLLER

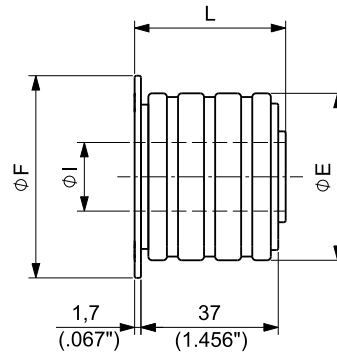

DOUBLE RUBBERIZED ROLLER

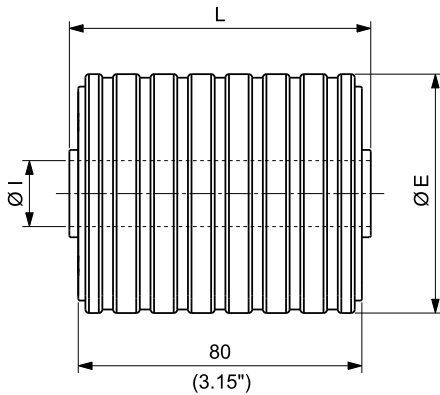

FLANGED RUBBERIZED DOUBLE ROLLER

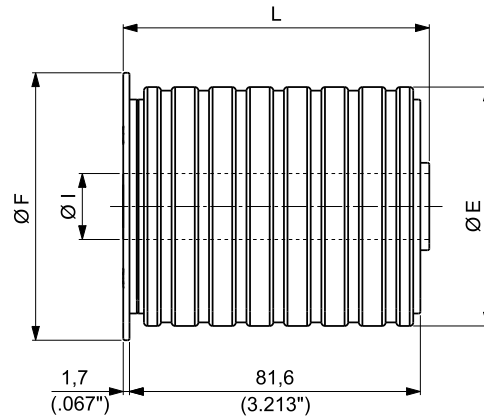

VERSION	EXTERNAL DIAMETER Ø E		LENGTH L		FLANGE DIAMETER Ø F		PART NUMBER FOR SHAFT DIAMETER Ø I			
	mm	inch	mm	inch	mm	inch	16 mm	18 mm	3/4"	20 mm
STANDARD RUBBERIZED ROLLER	45	1.772	41,0	1.614	-	-	CC000436	CC000439	CC000442	CC000445
	57	2.244	41,0	1.614	-	-	CC000437	CC000440	CC000443	CC000446
	67	2.638	41,0	1.614	-	-	CC000438	CC000441	CC000444	CC000447
DOUBLE RUBBERIZED ROLLER	45	1.772	82,5	3.248	-	-	CC000078	CC000084	CC000090	CC000096
			84,5	3.327	-	-	CC000079	CC000085	CC000091	CC000097
	57	2.244	82,5	3.248	-	-	CC000080	CC000086	CC000092	CC000098
			84,5	3.327	-	-	CC000081	CC000087	CC000093	CC000099
	67	2.638	82,5	3.248	-	-	CC000082	CC000088	CC000094	CC000100
			84,5	3.327	-	-	CC000083	CC000089	CC000095	CC000101
FLANGED RUBBERIZED ROLLER	45	1.772	41,0	1.614	55	2.165	CC000460	CC000463	CC000466	CC000469
	57	2.244	41,0	1.614	65	2.559	CC000461	CC000464	CC000467	CC000470
	67	2.638	41,0	1.614	75	2.953	CC000462	CC000465	CC000468	CC000471
FLANGED RUBBERIZED DOUBLE ROLLER	45	1.772	85,8	3.378	55	2.165	CC000114	CC000117	CC000120	CC000123
	57	2.244	85,8	3.378	65	2.559	CC000115	CC000118	CC000121	CC000124
	67	2.638	85,8	3.378	75	2.953	CC000116	CC000119	CC000122	CC000125



Standard packaging:  
50 pieces

## GUIDE FLANGES

Lightweight design with excellent chemical resistance and no liquids absorption.

**NEW**



### MATERIALS

FLANGES: **PP** POLYPROPYLENE

#### STANDARD FLANGE

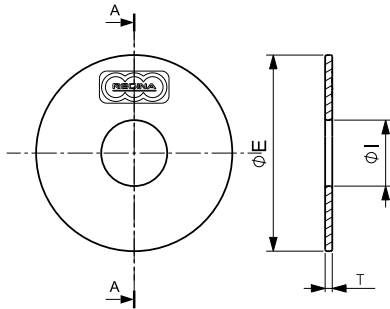

#### REDUCED THICKNESS FLANGE

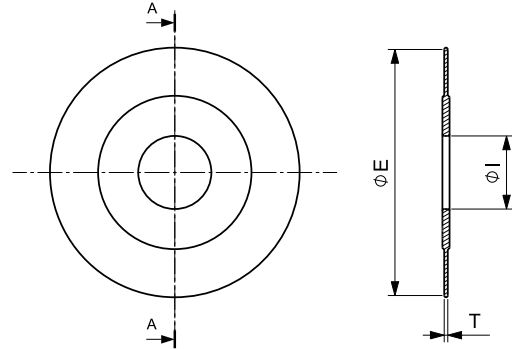

VERSION	EXTERNAL DIAMETER $\phi E$		THICKNESS T		PART NUMBER FOR SHAFT DIAMETER $\phi_1$			
	mm	inch	mm	inch	16 mm	18 mm	3/4"	20 mm
STANDARD FLANGE	55	2.165	2,0	0.079	<b>CC000126</b>	<b>CC000129</b>	<b>CC000132</b>	<b>CC000135</b>
	65	2.559	2,0	0.079	<b>CC000127</b>	<b>CC000130</b>	<b>CC000133</b>	<b>CC000136</b>
	75	2.953	2,0	0.079	<b>CC000128</b>	<b>CC000131</b>	<b>CC000134</b>	<b>CC000137</b>
REDUCED THICKNESS FLANGE	40	1.575	1,0	0.039	<b>CC000138</b>	<b>CC000139</b>	<b>CC000140</b>	<b>CC000141</b>
	70	2.756	1,0	0.039	<b>CC000142</b>	<b>CC000143</b>	<b>CC000144</b>	<b>CC000145</b>



Standard packaging:  
100 pieces

## RETURN SHOE GUIDE

The use of the shoe guide is recommended to support LBP chains in return parts and after the catenary sag close to drive sprockets.

**NEW**

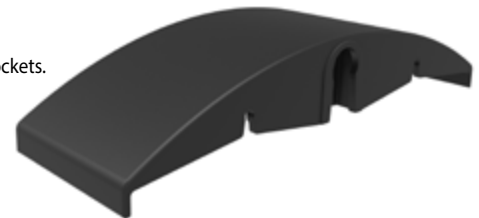

### MATERIALS

RETURN SHOE GUIDE: **HDPE** HD POLYETHYLENE

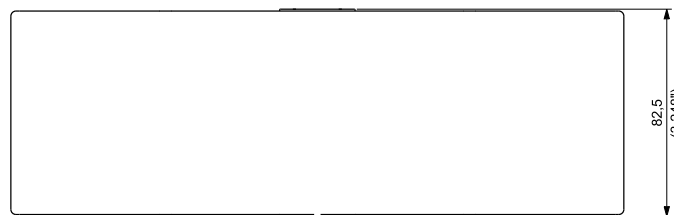
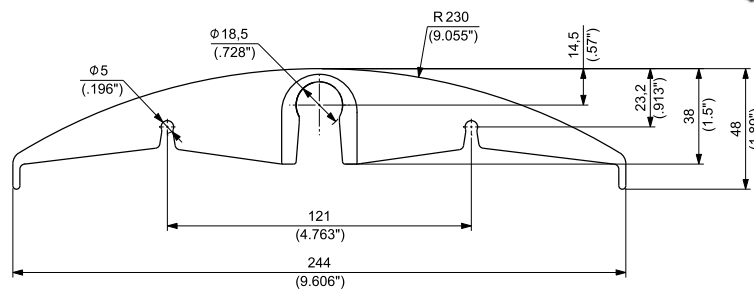

PART NUMBER **CC000150**

Very low coefficient of friction for low chain pull and energy saving.  
High wear resistance for extended chains and wear strips life.

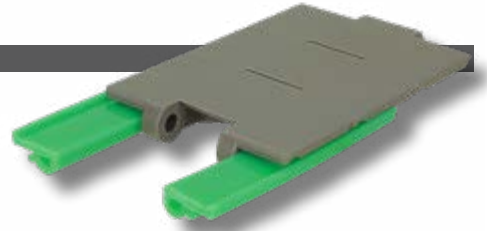

## L-PROFILE

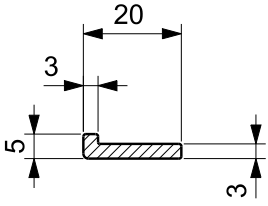

MATERIAL	PART NUMBER	STANDARD PACKAGING
<b>UHMWPE</b>	<b>WS003B</b>	60 M COILS
<b>UHMWPE</b>	<b>WS003G</b>	60 M COILS

## APPLICATION

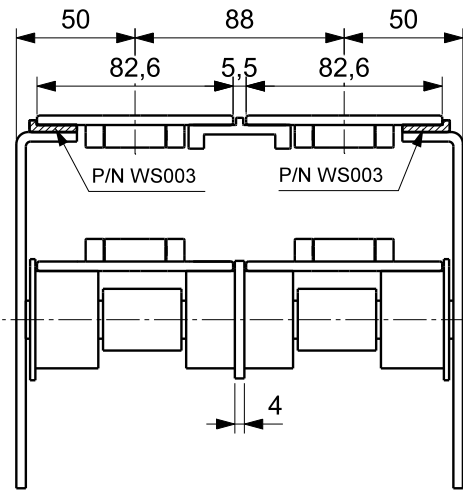

## Z-PROFILE

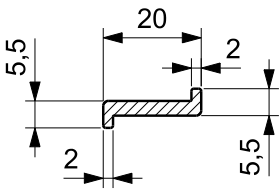

MATERIAL	PART NUMBER	STANDARD PACKAGING
<b>UHMWPE</b>	<b>WS001B</b>	60 M COILS
<b>UHMWPE</b>	<b>WS001G</b>	60 M COILS

## APPLICATION

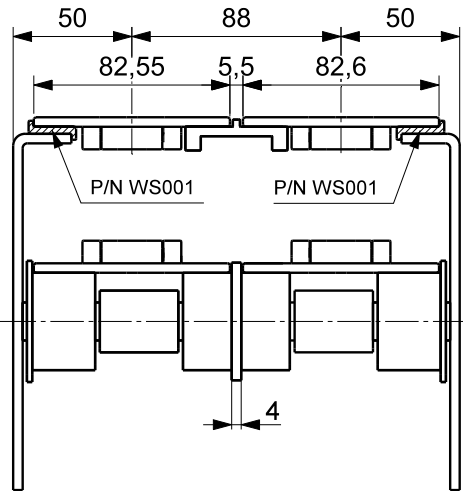

## Z REINFORCED-PROFILE

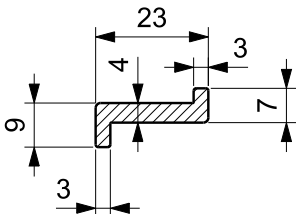

MATERIAL	PART NUMBER	STANDARD PACKAGING
<b>UHMWPE</b>	<b>WS004B</b>	60 M COILS
<b>UHMWPE</b>	<b>WS004G</b>	60 M COILS

## APPLICATION

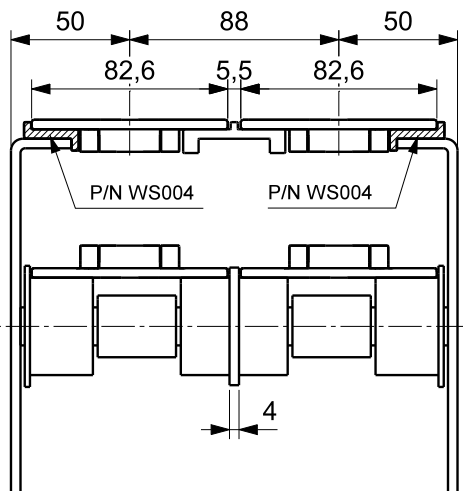

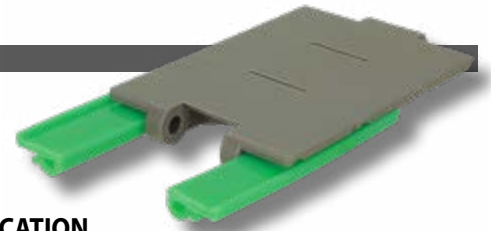

## LS-PROFILE

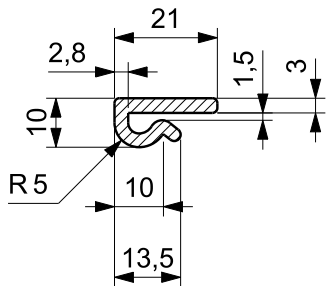

MATERIAL	PART NUMBER	STANDARD PACKAGING
<b>UHMWPE</b>	<b>WS008B</b>	60 M COILS
<b>UHMWPE</b>	<b>WS008G</b>	60 M COILS

## APPLICATION

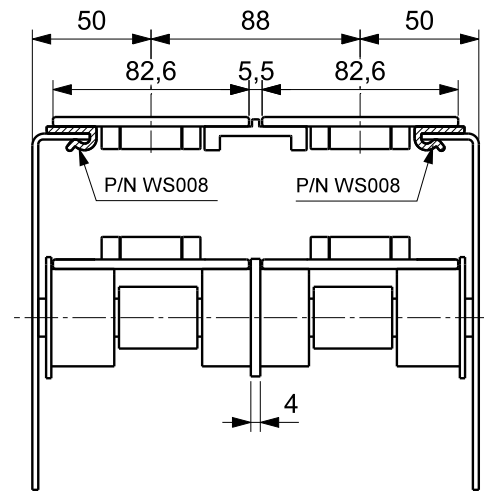

## ZS-PROFILE

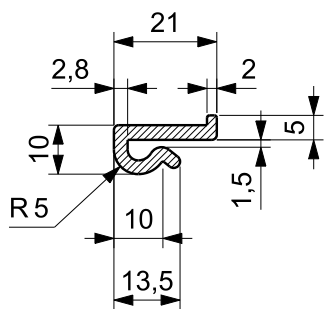

MATERIAL	PART NUMBER	STANDARD PACKAGING
<b>UHMWPE</b>	<b>WS007B</b>	60 M COILS
<b>UHMWPE</b>	<b>WS007G</b>	60 M COILS

## APPLICATION

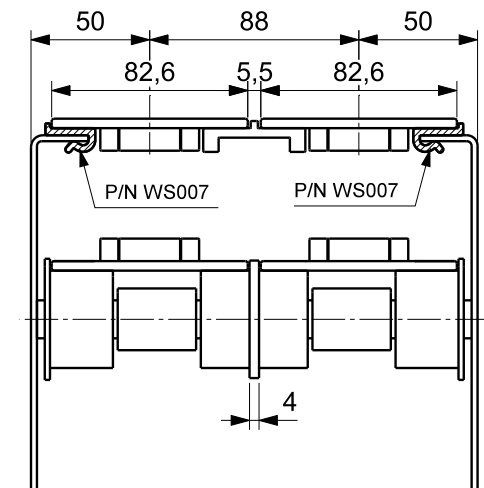

## T-PROFILE

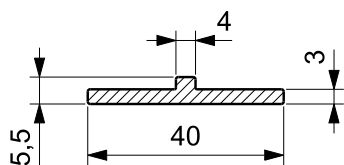

MATERIAL	PART NUMBER	STANDARD PACKAGING
<b>UHMWPE</b>	<b>WS002B</b>	60 M COILS
<b>UHMWPE</b>	<b>WS002G</b>	60 M COILS

## APPLICATION

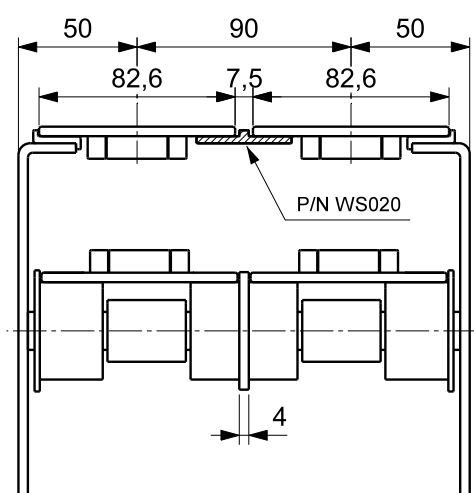

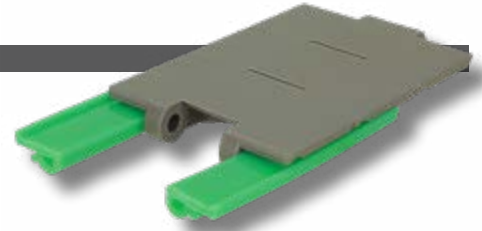

## U-PROFILE

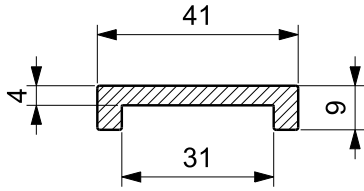

MATERIAL	PART NUMBER	STANDARD PACKAGING
UHMWPE	WS006BS	3 M BARS
	WS006B	6 M BARS
UHMWPE	WS006GS	3 M BARS
	WS006G	6 M BARS

## APPLICATION

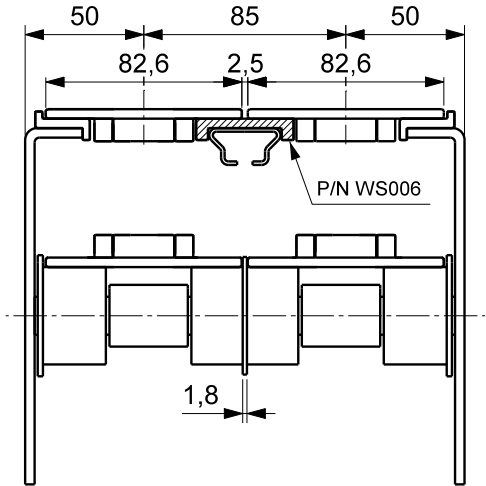

## T-PROFILE

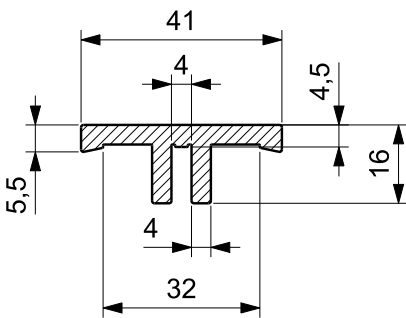

MATERIAL	PART NUMBER	STANDARD PACKAGING
UHMWPE	WS022B	3 M BARS
UHMWPE	WS022G	3 M BARS

## APPLICATION

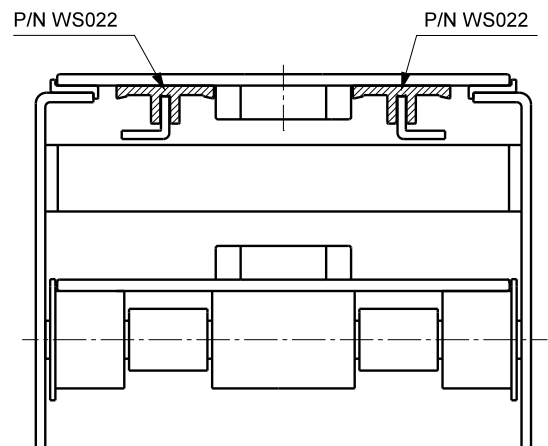

## U-PROFILE

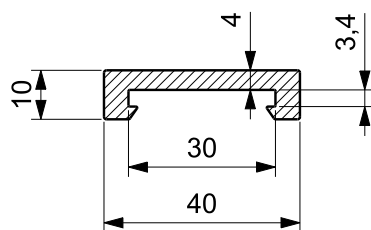

MATERIAL	PART NUMBER	STANDARD PACKAGING
UHMWPE	WS023BS	3 M BARS
	WS023B	6 M BARS
UHMWPE	WS023GS	3 M BARS
	WS023G	6 M BARS

## APPLICATION

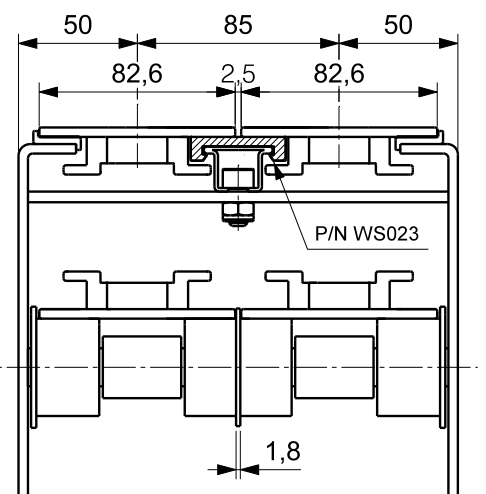



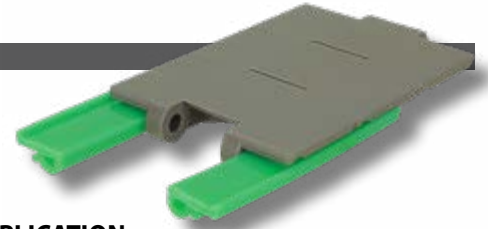

## UR-PROFILE

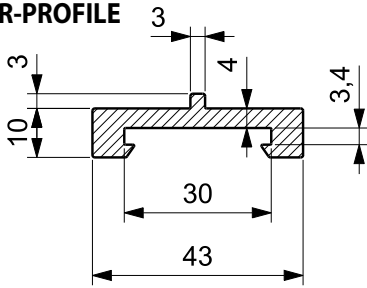

MATERIAL	PART NUMBER	STANDARD PACKAGING
UHMWPE	WS024BS	3 M BARS
	WS024B	6 M BARS
UHMWPE	WS024GS	3 M BARS
	WS024G	6 M BARS

## APPLICATION

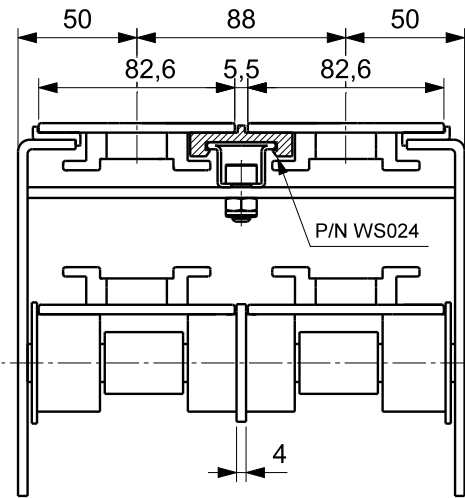

## I-PROFILE

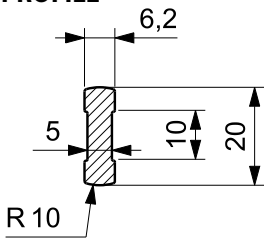

MATERIAL	PART NUMBER	STANDARD PACKAGING
UHMWPE	WS021B	60 M COILS
UHMWPE	WS021G	60 M COILS

## APPLICATION

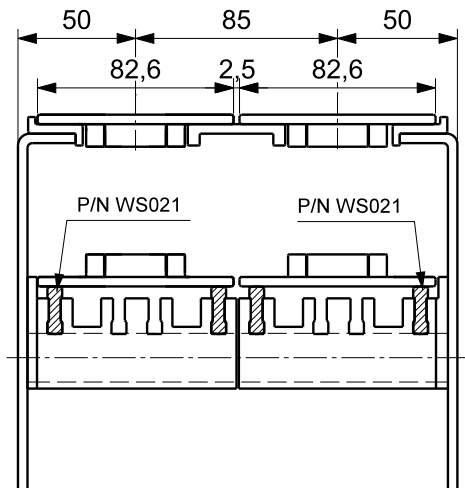

## I-PROFILE

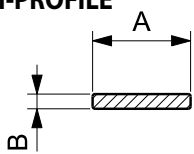

MATERIAL	PART NUMBER	AxB	STANDARD PACKAGING
UHMWPE	WS030B	20x3	60 M COILS
	WS031B	20x5	60 M COILS
	WS032B	60x3	60 M COILS
	WS033B	70x3	60 M COILS
UHMWPE	WS030G	20x3	60 M COILS
	WS031G	20x5	60 M COILS
	WS032G	60x3	60 M COILS
	WS033G	70x3	60 M COILS

## APPLICATION

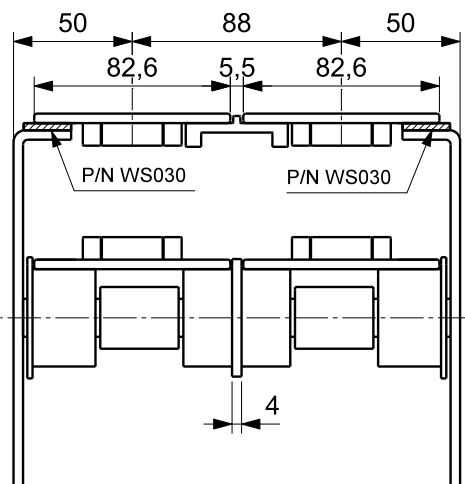

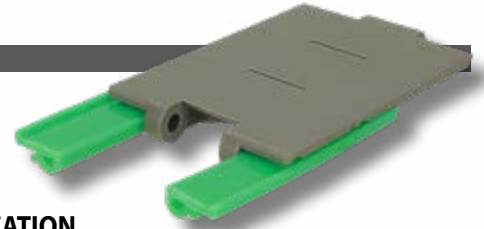

## C-PROFILE

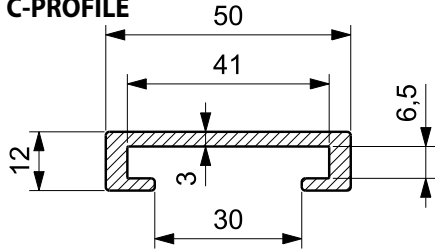

MATERIAL	PART NUMBER	STANDARD PACKAGING
UHMWPE	WS025BS	3 M BARS
	WS025B	6 M BARS
UHMWPE	WS025GS	3 M BARS
	WS025G	6 M BARS

## APPLICATION

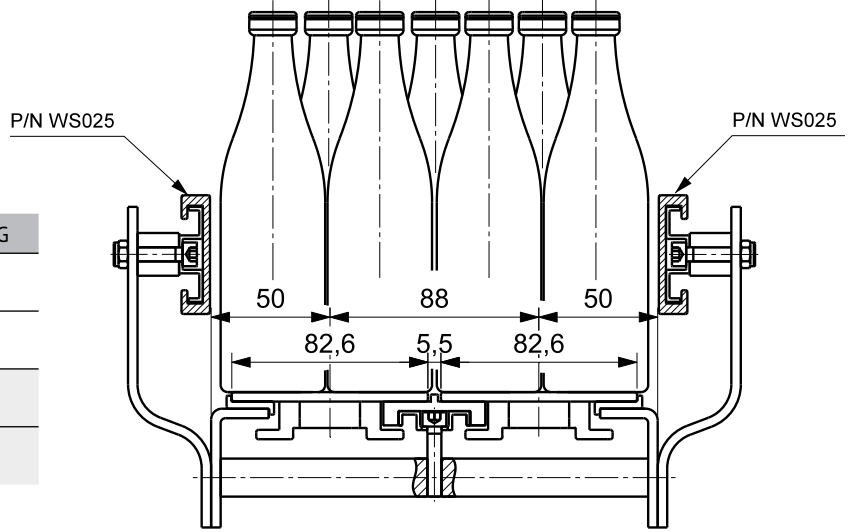

## C-PROFILE

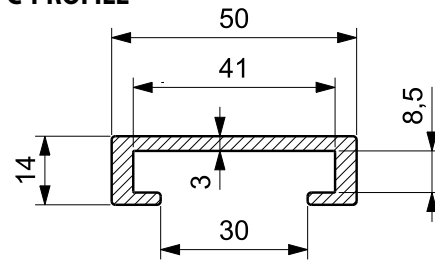

MATERIAL	PART NUMBER	STANDARD PACKAGING
UHMWPE	WS010BS	3 M BARS
	WS010B	6 M BARS
UHMWPE	WS010GS	3 M BARS
	WS010G	6 M BARS

## APPLICATION

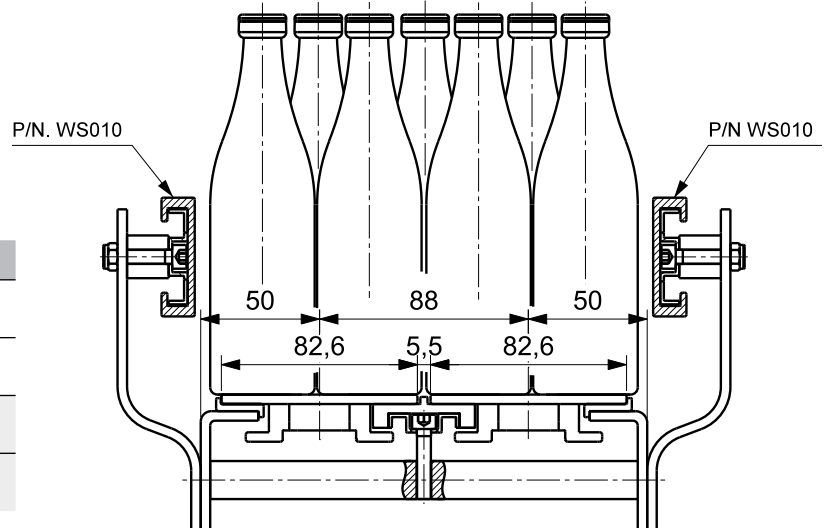

## D-PROFILE

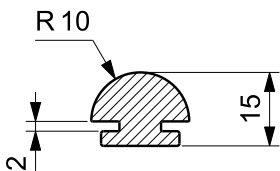

MATERIAL	PART NUMBER	STANDARD PACKAGING
UHMWPE	WS026BS	3 M BARS
	WS026B	6 M BARS
UHMWPE	WS026GS	3 M BARS
	WS026G	6 M BARS

## APPLICATION

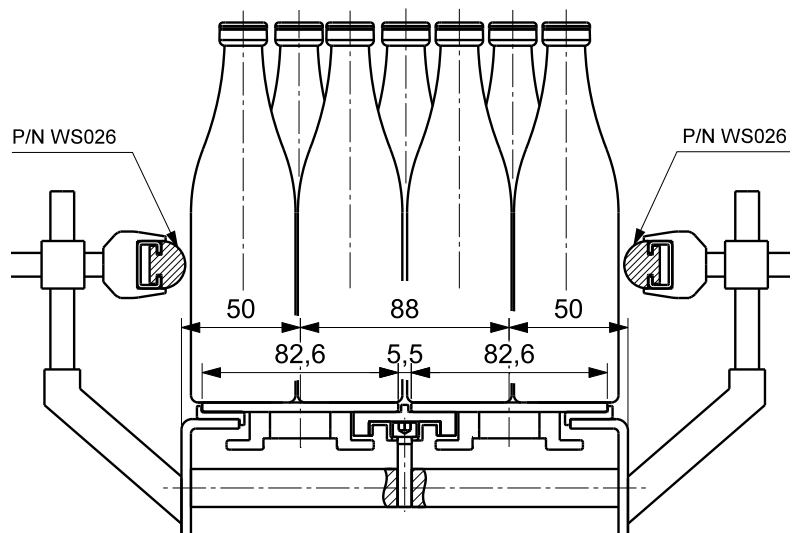

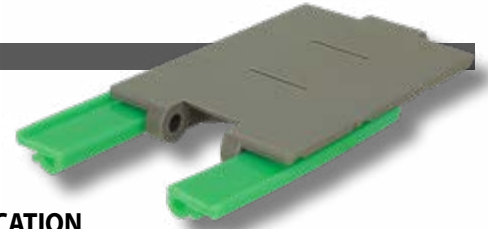

## DF-PROFILE

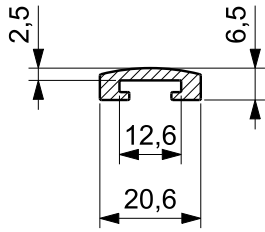

MATERIAL	PART NUMBER	STANDARD PACKAGING
UHMWPE	WS027BS	3 M BARS
	WS027B	6 M BARS
UHMWPE	WS027GS	3 M BARS
	WS027G	6 M BARS

## APPLICATION

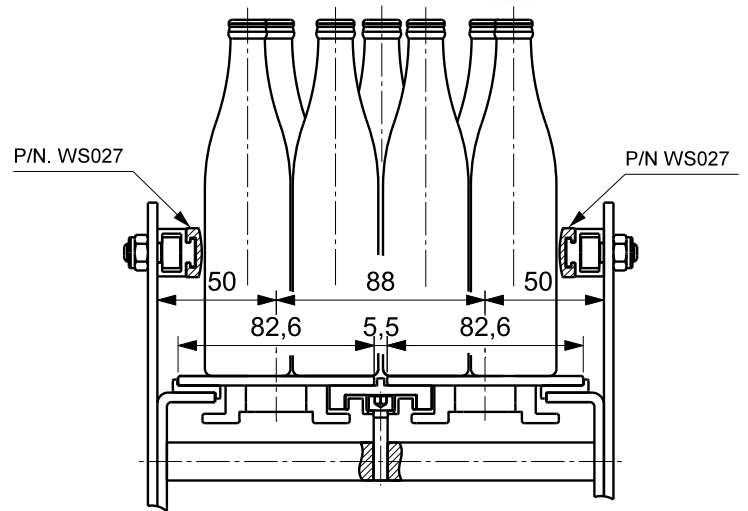

## DR-PROFILE

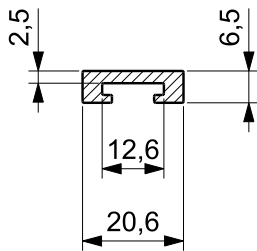

MATERIAL	PART NUMBER	STANDARD PACKAGING
UHMWPE	WS028BS	3 M BARS
	WS028B	6 M BARS
UHMWPE	WS028GS	3 M BARS
	WS028G	6 M BARS

## APPLICATION

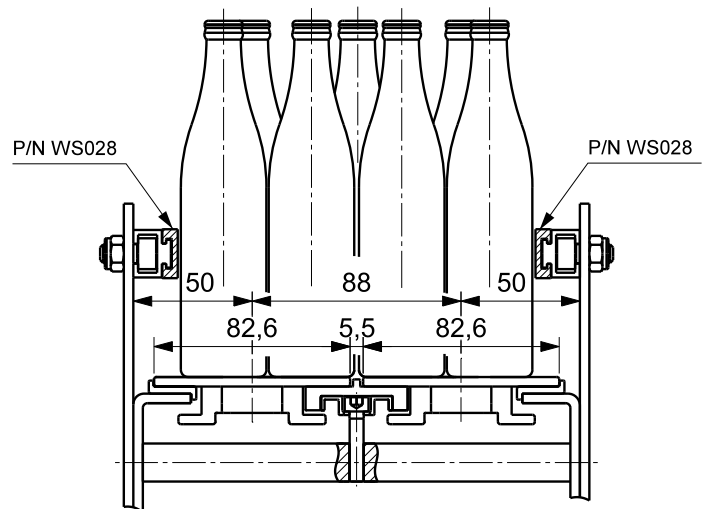

The side guides provides low friction and smooth consistent contact with the products for the maximum sability. It is ideal for PET or glass bottles, also where label protection is critical. The side guides are supplied without clamp. It can be ordered using the P/N CC000307.

**NEW**



### LABEL PROTECTION PROFILE

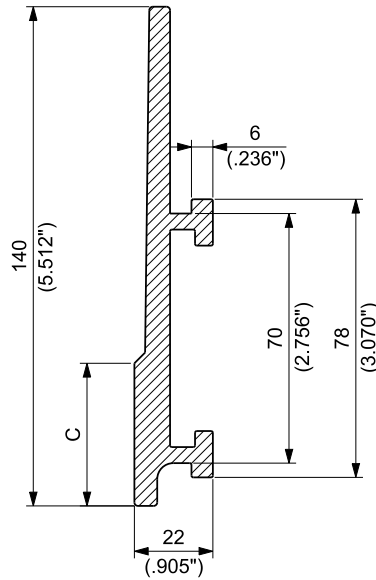

### STAINLESS STEEL CLAMP

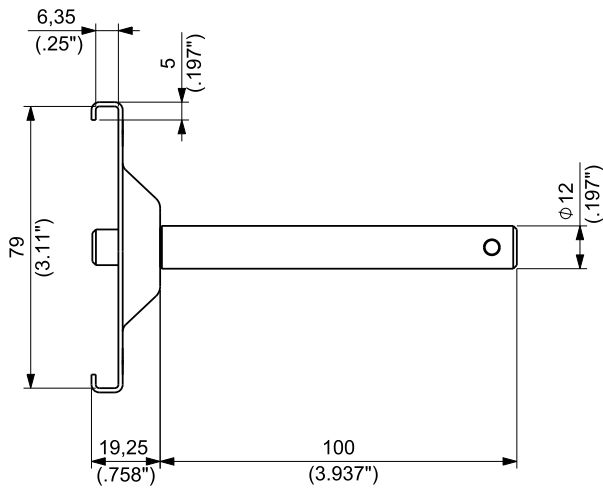

PART NUMBER **CC000307**

Standard packaging:  
30 pieces

### ASSEMBLY EXAMPLE

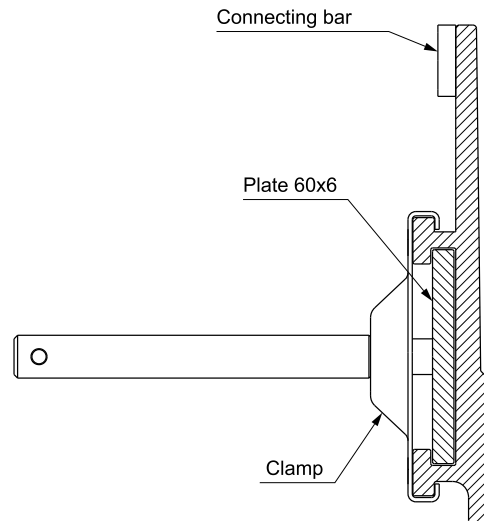

MATERIAL	VERSION	PART NUMBER	C		FOR PLATE mm	STANDARD PACKAGING
			mm	inch		
HDPE	NO LABEL PROTECTION	<b>CC000300</b>	-	-	60x6	3 M BARS
		<b>CC000303</b>	5	0.197		
	WITH LABEL PROTECTION	<b>CC000301</b>	20	0.787		
		<b>CC000302</b>	40	1.575		

A large area of the page is filled with horizontal dotted lines, providing a template for handwritten notes.

A large area of the page is filled with horizontal dotted lines, providing a space for handwritten notes.



A series of horizontal dotted lines for writing notes.

A large area of the page is filled with horizontal dotted lines, providing a space for handwritten notes.



## PERFORMANCE IN MOTION

### ITALY

REGINA CATENE CALIBRATE S.p.A.  
HEAD OFFICE:  
Via Monza, 90  
23870 Cernusco Lombardone (LC) - Italy  
Tel. +39 039 99801  
Fax +39 039 9905229  
sales@reginachain.net

### MEXICO

REGINA de MEXICO S.A. de C.V.  
Av. Aviación 5051-28  
Col. San Juan de Ocotan  
45019 Zapopan, Jalisco – Mexico  
Tel. +52 33 3627 4043  
Fax +52 33 3627 3930  
sales.mx@reginachain.net

### ARGENTINA

REGINA INTERNATIONAL S.A.  
Diagonal 190,  
1788-1655 José Leon Suarez  
Prov. Buenos Aires – Argentina  
Tel. +54 11 47296667  
Fax +54 11 47203210  
sales.ar@reginachain.net

### USA

REGINA USA, INC.  
305 E. Mahn Court  
Oak Creek, WI 53154 - USA  
Tel. 001 414 5710032  
Fax 001 414 5710225  
sales.us@reginachain.net

### CHINA

REGINA TIANJIN CHAIN & BELT CO., LTD.  
Xi Qing Economic Development Area,  
Xiang Rui Road n. 17  
Tian Xiang Industrial Zone  
300385 Tian Jin - China  
Tel. +86 22 83961223  
Fax +86 22 83961202  
sales.cn@reginachain.net

### GERMANY

SALES OFFICE  
Tel. +49 1705251348  
Fax +49 7181489535  
sales.de@reginachain.net

### THE NETHERLANDS

SALES OFFICE  
Tel. +31 610681114  
sales.nl@reginachain.net

### FRANCE

REGINA INDUSTRIE s.a.r.l.  
Z.A.C. des Chatelliers  
34 Rue des Frères Lumière  
45800 Saint Jean De Braye - France  
Tel. +33 238 836363  
Fax +33 238 836413  
sales.fr@reginachain.net

### UNITED KINGDOM

REGINA INTERNATIONAL LIMITED  
Unit 1, Dyneley Road,  
Greenbank Business Park  
Whitebirk, Blackburn,  
Lancs BB1 3AB - United Kingdom  
Tel. +44 1254 661116  
Fax +44 1254 59456  
sales.uk@reginachain.net

### SPAIN

CADENAS REGINA ESPAÑA, S.L.  
Calle Industria, 37  
08120 La Llagosta - Barcelona - España  
Tel. +34 93 5742838  
Fax +34 93 5740735  
sales.es@reginachain.net

### INDIA

SALES OFFICE  
Tel. +91 9881399026  
sales.in@reginachain.net

